

SHARP

OPTO-ANALOG DEVICES DIVISION
 ELECTRONIC COMPONENTS GROUP
 SHARP CORPORATION

SPECIFICATION

DEVICE SPECIFICATION FOR

PHOTOCOUPLER

MODEL No.

PC410L

	Business dealing name		Business dealing name
○	PC410LENIP0F		PC410LEYIP0F

Specified for _____

Enclosed please find copies of the Specifications which consists of 16 pages including cover.
 This specification sheets and attached sheets shall be both side copy.
 After confirmation of the contents, please be sure to send back copies of the Specifications
 with approving signature on each.

CUSTOMER'S APPROVAL

PRESENTED

DATE _____

DATE June 21, 2007

BY _____

BY H. Imanaka

H. Imanaka,
 Department General Manager of
 Engineering Dept., II
 Opto-Analog Devices Div.
 ELECOM Group
 SHARP CORPORATION



Product name : PHOTOCOUPLER

Model No. : PC410L

Business dealing name	Business dealing name
PC410LENIP0F	PC410LEYIP0F

1. These specification sheets include materials protected under copyright of Sharp Corporation ("Sharp"). Please do not reproduce or cause anyone to reproduce them without Sharp's consent.
2. When using this product, please observe the absolute maximum ratings and the instructions for use outlined in these specification sheets, as well as the precautions mentioned below. Sharp assumes no responsibility for any damage resulting from use of the product which does not comply with the absolute maximum ratings and the instructions included in these specification sheets, and the precautions mentioned below.

(Precautions)

- (1) This product is designed for use in the following application areas ;

(· OA equipment · Audio visual equipment · Home appliances
· Telecommunication equipment (Terminal) · Measuring equipment
· Tooling machines · Computers)

If the use of the product in the above application areas is for equipment listed in paragraphs (2) or (3), please be sure to observe the precautions given in those respective paragraphs.

- (2) Appropriate measures, such as fail-safe design and redundant design considering the safety design of the overall system and equipment, should be taken to ensure reliability and safety when this product is used for equipment which demands high reliability and safety in function and precision, such as ;

(· Transportation control and safety equipment (aircraft, train, automobile etc.)
· Traffic signals · Gas leakage sensor breakers · Rescue and security equipment
· Other safety equipment)

- (3) Please do not use this product for equipment which require extremely high reliability and safety in function and precision, such as ;

(· Space equipment · Telecommunication equipment (for trunk lines)
· Nuclear power control equipment · Medical equipment)

- (4) Please contact and consult with a Sharp sales representative if there are any questions regarding interpretation of the above three paragraphs.

3. Please contact and consult with a Sharp sales representative for any questions about this product.

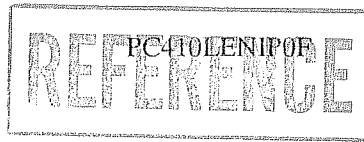

1. Application

This specification applies to the outline and characteristics of OPIC photocoupler Model No. PC410L (Lead free type).

2. Outline Refer to the attached sheet, page 4.

3. Ratings and characteristics Refer to the attached sheet, page 5, 6.

4. Reliability Refer to the attached sheet, page 7.

5. Outgoing inspection Refer to the attached sheet, page 8.

6. Supplement

6.1 Isolation voltage shall be measured in the following method.

- (1) Short between pins 1 and 3 on the primary side and between pins 4, 5 and 6 on the secondary side.
- (2) The dielectric withstanding tester with zero-cross circuit shall be used.
- (3) The wave form of applied voltage shall be a sine wave.
(It is recommended that the isolation voltage be measured in insulation oil.)

6.2 Business dealing name

("○" mark indicates business dealing name of ordered product)

Product	Business dealing name	Remark
○	PC410LENIP0F	
	PC410LEYIP0F	Applied to product as a option (Attachment-2-1 to 2-3.)

6.3 Package specification Refer to the attached sheet, page 9, 10.

6.4 This Model is approved by UL.

Approved Model No. : PC410L
UL file No. : E64380

6.5 This product is not designed against irradiation.

This product is operated with electrical input and output.
This product incorporates non-coherent light emitting diode.

6.6 ODS materials

This product shall not contain the following materials.

Also, the following materials shall not be used in the production process for this product.

Materials for ODS : CFCs, Halon, Carbon tetrachloride, 1.1.1-Trichloroethane (Methyl chloroform)

6.7 Specified brominated flame retardants

Specified brominated flame retardants (PBB and PBDE) are not used in this device at all.

6.8 The block diagram

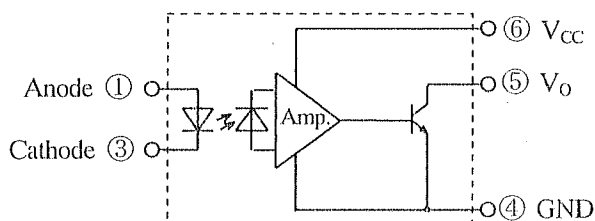



6.9 Compliance with each regulation

- (1) The RoHS directive (2002/95/EC)

This product complies with the RoHS directive (2002/95/EC) .

Object substances: mercury, lead, cadmium, hexavalent chromium, polybrominated biphenyls (PBB)
and polybrominated diphenyl ethers (PBDE)

- (2) Content of six substances specified in Management Methods for Control of Pollution Caused by Electronic Information Products Regulation (Chinese : 电子信息产品污染控制管理办法).

Category	Toxic and hazardous substances					
	Lead (Pb)	Mercury (Hg)	Cadmium (Cd)	Hexavalent chromium (Cr ⁶⁺)	Polybrominated biphenyls (PBB)	Polybrominated diphenyl ethers (PBDE)
Photocoupler	✓	✓	✓	✓	✓	✓

✓: indicates that the content of the toxic and hazardous substance in all the homogeneous materials of the part is below the concentration limit requirement as described in SJ/T 11363-2006 standard .

7. Notes

Precautions for photocouplers : attachment-1

2. Outline

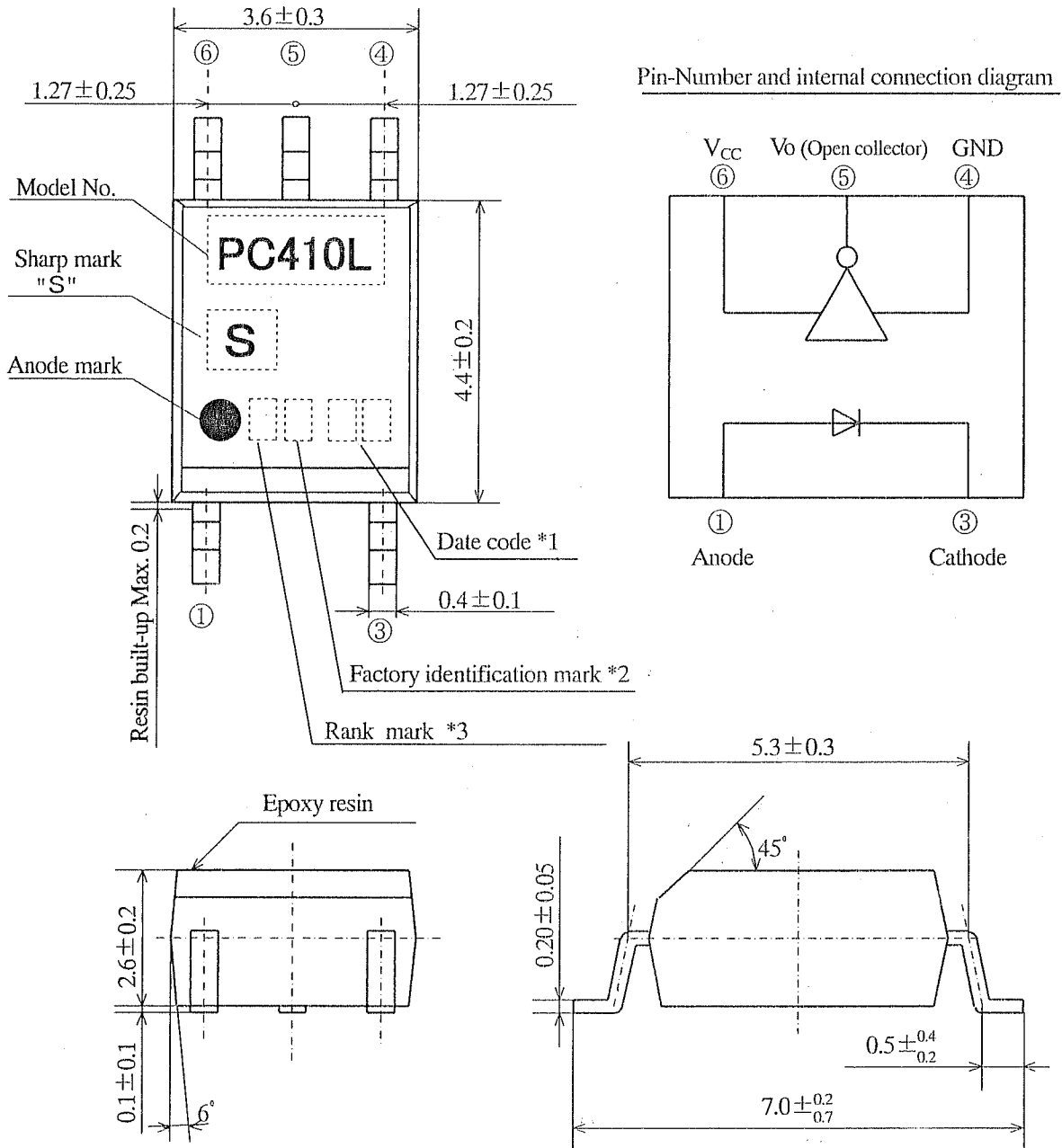

*1) 2-digit number shall be marked according to OLD DIN standard.

*2) Factory identification mark applies to the below.

Without : SUN-S Corporation (Japan)

- Pin material : 42 Alloy
- Pin finish : SnCu plating (Cu : TYP. 2%)
- Marking is ink marking

: P.T.SHARP SEMICONDUCTOR INDONESIA (INDONESIA)

- Pin material: Cu Alloy
- Pin finish: Palladium (Au flash plating)
- Marking is laser marking

*3) Rank mark shall be or shall not be marked.

Product mass : Approx. 0.1g

UNIT : 1/1 mm	
Name	PC410L Outline Dimensions (Business dealing name : PC410LENIPOF)

3. Ratings and characteristics

3.1 Absolute maximum ratings

Ta=25°C

Parameter		Symbol	Rating	Unit
Input	*1 Forward current	I_F	20	mA
	Reverse voltage	V_R	5	V
	Power dissipation	P	40	mW
Output	Supply voltage	V_{CC}	7	V
	High level output voltage	V_{OH}	7	V
	Low level output current	I_{OL}	50	mA
	*2 Output collector power dissipation	P_c	85	mW
*3 Isolation voltage	$V_{iso (rms)}$		3.75	kV
Operating temperature		T_{opr}	-40 to +85	°C
Storage temperature		T_{stg}	-40 to +125	°C
*4 Soldering temperature		T_{sol}	270	°C

*1 The derating factors of forward current vs. ambient temperature are shown in Fig. 3.

*2 The derating factors of output collector power dissipation due to ambient temperature are shown in Fig. 4.

*3 AC for 1 min, 40 to 60%RH

*4 For 10 s or less.

3.2 Electro-optical characteristics

(Ta=-40 to +85°C unless otherwise specified, All typical specifications are at Ta=25°C, V_{CC}=5V.)

Parameter		Symbol	Conditions	MIN.	TYP.	MAX.	Unit	
Input	Forward voltage	V_F	Ta=25°C, $I_F=10mA$	1.4	1.6	1.9	V	
	Reverse current	I_R	Ta=25°C, $V_R=5V$	-	-	10	μA	
	Terminal capacitance	C_t	Ta=25°C, $V_F=0$, f=1MHz	-	60	150	pF	
Output	Low level output voltage	V_{OL}	$I_{OL}=13mA$, $V_{CC}=5.5V$, $I_F=5mA$	-	0.4	0.6	V	
	High level output current	I_{OH}	$V_{CC}=V_o=5.5V$, $I_F=250\mu A$	-	0.02	100	μA	
	Low level supply current	I_{CCL}	$V_{CC}=5.5V$, $I_F=10mA$	-	7	13	mA	
	High level supply current	I_{CCH}	$V_{CC}=5.5V$, $I_F=0$	-	5	10	mA	
Transfer characteristics	"H→L" threshold input current	I_{FHL}	$V_{CC}=5V$, $V_o=0.8V$, $R_L=350\Omega$		2.5	5	mA	
	Isolation resistance	R_{ISO}	Ta=25°C, DC500V 40 to 60%RH	5×10^{10}	10^{11}	-	Ω	
	Floating capacitance	C_f	Ta=25°C, V=0, f=1MHz	-	0.6	-	pF	
	Response time	"H→L" propagation time	t_{PHL}	Ta=25°C $V_{CC}=5V$, $I_F=7.5mA$ $R_L=350\Omega$, $C_L=15pF$ (Refer to Fig. 1)	25	48	75	ns
		"L→H" propagation time	t_{PLH}		25	50	75	
		Fall time	t_f		-	10	-	
		Rise time	t_r		-	20	-	
		Distortion of pulse width *5	Δtw		-	-	35	
CMR	Instantaneous common mode rejection voltage (High level output)	CM_H	$I_F=0$, $V_o (MIN)=2V$	10	20	-	kV/μs	
	Instantaneous common mode rejection voltage (Low level output)	CM_L	$I_F=5mA$, $V_o (MAX)=0.8V$	-10	-20	-		

*5 Distortion of pulse width $\Delta tw = |t_{PHL} - t_{PLH}|$

Fig.1 t_{PHL} , t_{PLH} , t_r , t_f test circuit

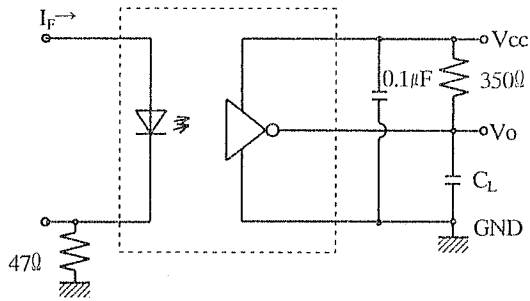

* C_L contains probe and wiring capacity.

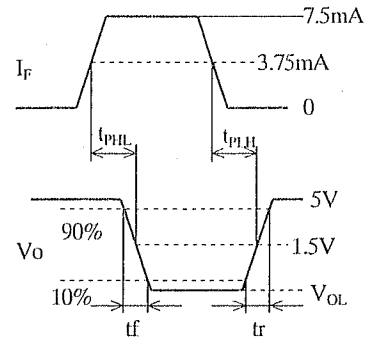

Timing diagram

Fig.2 CM_H , CM_L test circuit

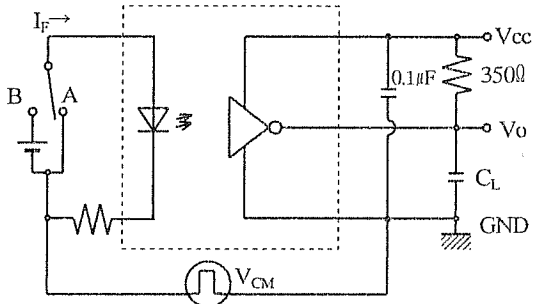

* C_L contains probe and wiring capacity.

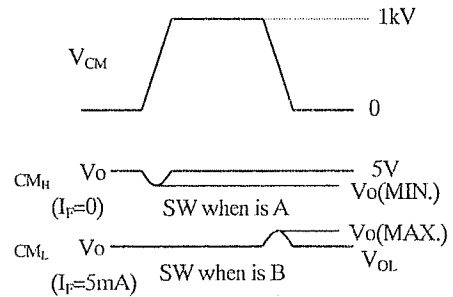

Timing diagram

(Fig.3) Forward current vs. ambient temperature

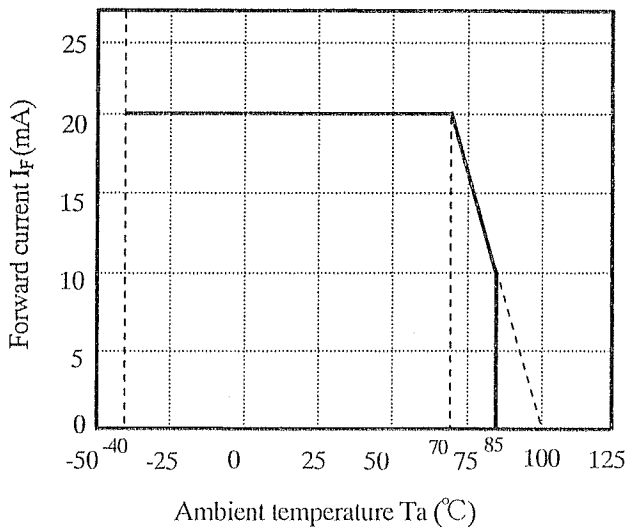

(Fig.4) Output collector power dissipation vs. ambient temperature

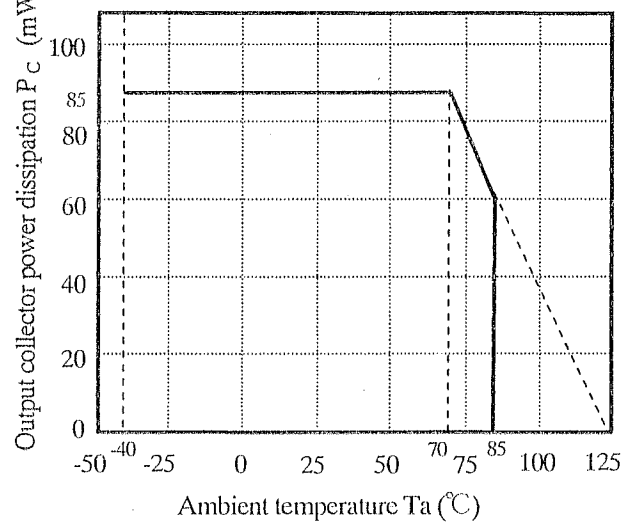

4. Reliability

The reliability of products shall satisfy items listed below.

Confidence level : 90%

LTPD : 10 or 20

Test Items	Test Conditions *1	Failure Judgment Criteria	Samples (n)
			Defective(C)
Solderability *2	245±3°C, 5s	—————	n=11, C=0
Soldering heat *3	(Flow soldering) 270°C, 10s	$V_F > U \times 1.2$ $I_R > U \times 2$ $I_{OH} > U \times 2$ $I_{CCL} > U \times 1.2$ $I_{CCH} > U \times 1.2$ $I_{FHL} > U \times 1.3$ $V_{OL} > U \times 1.2$ U : Upper specification limit L : Lower specification limit	n=11, C=0
	(Soldering by hand) 400°C, 3s		n=11, C=0
Terminal strength (Bending) *4	Weight : 1N 1 time/each terminal		n=11, C=0
Mechanical shock	15km/s ² , 0.5ms 3 times/±X, ±Y, ±Z direction		n=11, C=0
Variable frequency vibration	200m/s ² 100 to 2000 to 100Hz/4min. 4 times/ X, Y, Z direction		n=11, C=0
Temperature cycling	1 cycle -40°C to +125°C (30min.) (30min.) 20 cycles test		n=22, C=0
High temp. and high humidity Storage *5	+85°C, 85%RH, 500h		n=22, C=0
High temp. storage	+125°C, 1000h		n=22, C=0
Low temp. storage	-40°C, 1000h		n=22, C=0
Operation life	$I_F=20mA$, $V_{CC}=5.5V$, $R_L=350\Omega$, $T_a=25^\circ C$ 1000h		n=22, C=0

- *1 Test method, conforms to EIAJ ED 4701.
- *2 Solder shall adhere at the area of 95% or more of immersed portion of lead, and pin hole or other holes shall not be concentrated on one portion.
- *3 It is evaluated due to the temperature profile in attachment-1.
- *4 Terminal bending direction is shown below.
- *5 It is evaluated after washing by specified solvent in attachment-1.

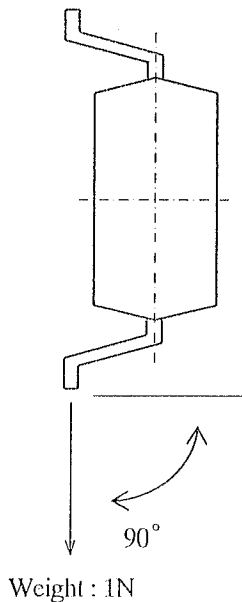

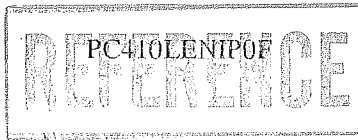

5. Outgoing inspection

5.1 Inspection items

(1) Electrical characteristics

$V_F, I_R, V_{OL}, I_{OH}, I_{CCL}, I_{CCH}, I_{FHL}, R_{ISO}, V_{ISO}$

(2) Appearance

5.2 Sampling method and Inspection level

A single sampling plan, normal inspection level II based on ISO 2859 is applied.

The AQL according to the inspection items are shown below.

Defect	Inspection item	AQL (%)
Major defect	Electrical characteristics Unreadable marking	0.065
Minor defect	Appearance defect except the above mentioned.	0.25

6.3 Package specifications

6.3.1 Taping conditions

- (1) Tape structure and Dimensions (Refer to the attached sheet, Page 9)

The carrier tape has the heat pressed structure of A-PET material carries tape of protect against static electricity and three layers cover tape (PET material base).

- (2) Reel structure and Dimensions (Refer to the attached sheet, Page 10)

The taping reel shall be of plastic (PS material).

- (3) Direction of product insertion (Refer to the attached sheet, Page 10)

- (4) Joint of tape

The cover tape and carrier tape in one reel shall be joint less.

- (5) To repair failure - taped devices, cutting a bottom of carrier tape with a cutter.

After replacing the cut portion shall be sealed with adhesive tape.

6.3.2 Adhesiveness of cover tape

- The exfoliation force between carrier tape and cover tape shall be 0.2N to 0.7N for the angle 160° to 180° .

6.3.3 Rolling method and quantity

- Wind the tape back on the reel so that the cover tape will be outside the tape.
- Attach more than 20cm of blank tape to the trailer and the leader of the tape and fix the both ends with adhesive tape.
One reel basically shall contain 3000pcs.

6.3.4 Outer packing appearance (Refer to attached sheet, Page 10)

6.3.5 Marking

- The label with following information shall be pasted at appointed place of the outer packing case.

* Model No. *(Business dealing name) * Lot No. * Quantity

* Country of origin *Company name *Inspection date specified

6.3.6 Storage condition

- Taped products shall be stored at the temperature 5 to 30°C and the humidity 70%RH or less away from direct sunlight.

6.3.7 Safety protection during shipping

- There shall be no deformation of component or degradation of electrical characteristics due to shipping.

Carrier tape structure and Dimensions

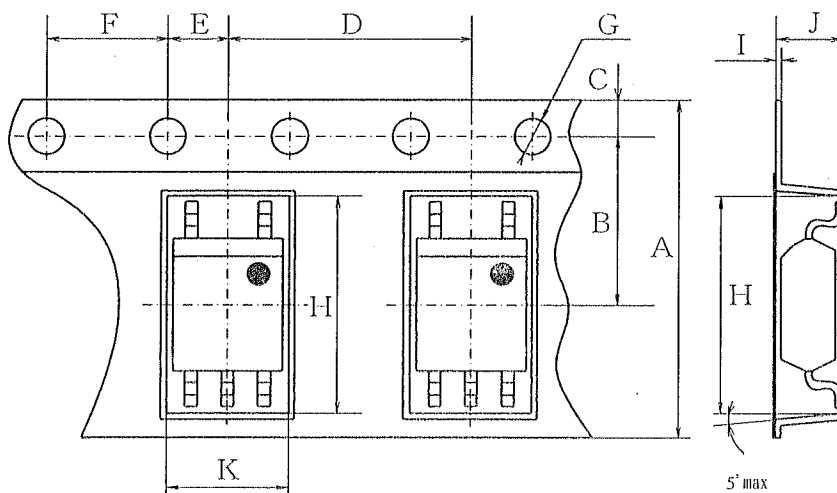

Dimensions list (Unit : mm)

A	B	C	D	E	F	G	H	I	J	K
±0.3	±0.05	±0.10	±0.1	±0.1	±0.1	+0.1 -0.0	±0.1	±0.05	±0.1	±0.1
12.0	5.50	1.75	8.0	2.0	4.0	φ1.5	7.4	0.30	3.1	4.0

Reel structure and Dimensions

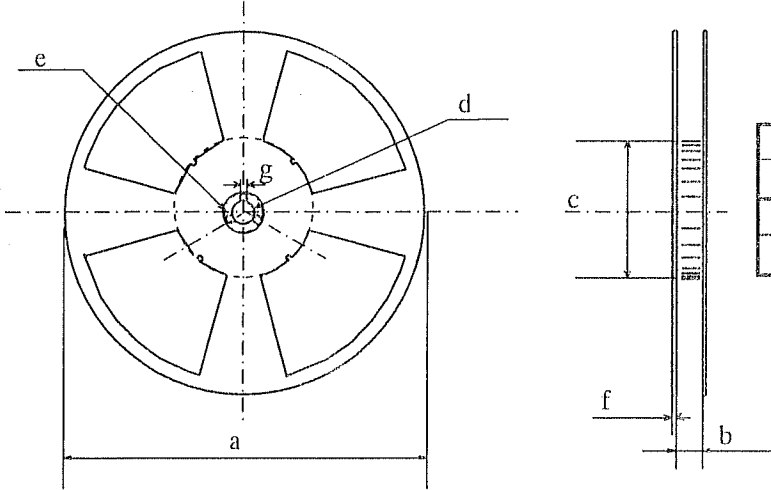

Dimensions list (Unit : mm)

a	b	c	d
(370)	13.5±1.5	φ 100.0±1.0	φ 13.0±0.5
e	f	g	
φ 21.0±1.0	2.0±0.5	2.0±0.5	

Direction of product insertion

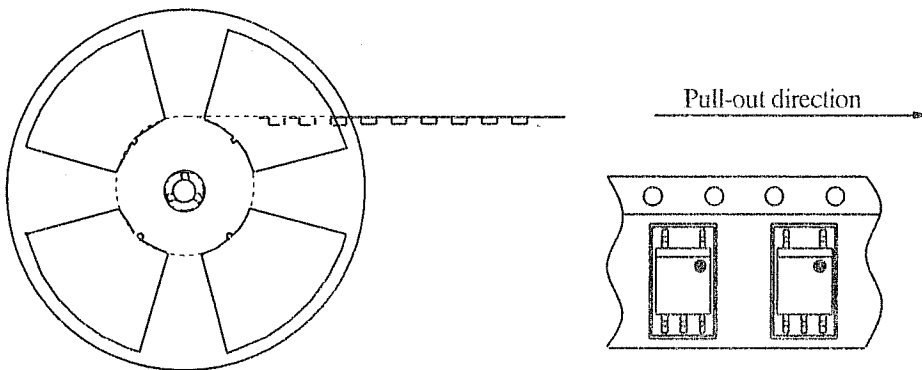

Outer packing appearance

- (1) Carrier tape with 3000pcs. of the devices (reeled) are packed in packing case.
 - (2) The packing case is sealed by kraft tape & the label is placed on it.
- (Max. 4 reels are packed in one carton. (Max. 12000pcs. of devices are in one carton.))

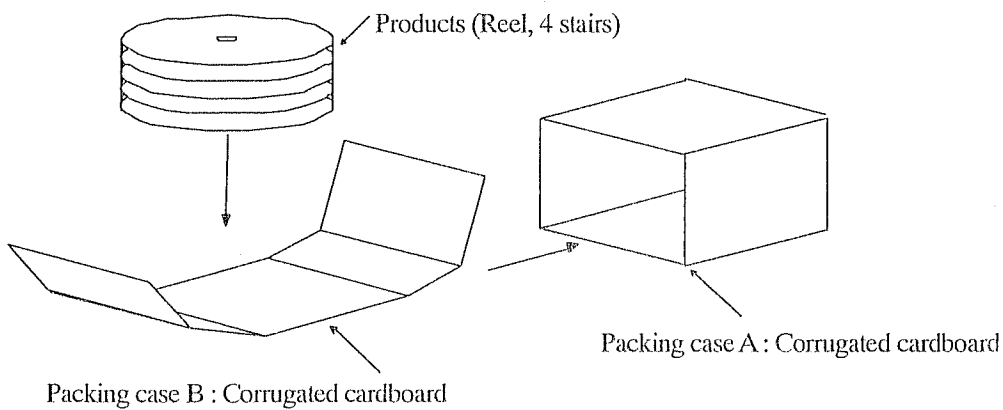

Regular packing mass : 3kg
() : Reference dimensions

Kraft tape (With SHARP mark)

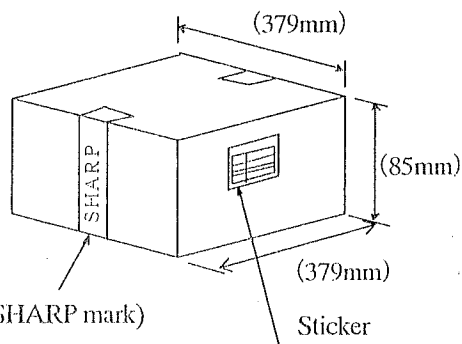

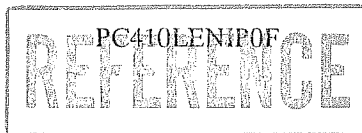

Precautions for Photocouplers

1. Recommended operating conditions

Parameter	Symbol	MIN.	MAX.	Unit
Low level input current	I _{FL}	0	250	μA
High level input current	I _{FH}	8	15	mA
Supply voltage	V _{CC}	4.5	5.5	V
Fan out (TTL load)	N	-	5	-
Operating temperature	T _{opr}	-40	+70	°C

We recommend that this device is used under the above conditions to secure reliability and allowance against time degradation of light emitting diode.

2. Cleaning

- (1) Solvent cleaning : Solvent temperature 45°C or less
Immersion for 3 min or less
- (2) Ultrasonic cleaning : The effect to device by ultrasonic cleaning differs by cleaning bath size, ultrasonic power output, cleaning time, PCB size or device mounting condition etc.
Please test it in actual using condition and confirm that any defect doesn't occur before starting the ultrasonic cleaning
- (3) Applicable solvent : Ethyl alcohol, Methyl alcohol, Isopropyl alcohol
When the other solvent is used, there are cases that the packaging resin is eroded.
Please use the other solvent after thorough confirmation is performed in actual using condition.

3. Static electricity

Transistor of detector side in bipolar configuration is apt to be affected by static electricity for its minute design. When handling them, general countermeasure against static electricity should be taken to avoid breakdown and devices and degradation of characteristics.

4. Circuit design

- 4.1 In order to stabilize power supply line, we should certainly recommend to connect a by-pass capacitor of 0.01 μF or more between V_{CC} and GND near the device.
- 4.2 When steep voltage noise is applied between the primary side and the secondary side of the photocoupler, current flows or changes in the light emitting diode through a parasitic capacitance between the primary side and the secondary side of the photocoupler, then there is a case that miss operation occurs depending upon the applied noise level.
We should certainly recommend to use a by-pass capacitor between both terminals of the light emitting diode when used in noisy environment.
- 4.3 The detector which is used in this device has parasitic diode between each pins and GND.
There are cases that miss operation or destruction may be occurred if electric potential of any pin fall below GND level in an instant.
Therefore it is recommended to design the circuit that electric potential of any pin does not become below GND level.
- 4.4 The LED used in the Photocoupler generally decreases the light emission power by operation.
In case of long operation time, please design I_F value so that I_F is twice or more of the Maximum value of the "H→L" threshold input current at circuit design with considering the decreases of the light emission power of the LED. (50%/5years)

5. Precautions for Soldering Photocouplers

(1) In the case of flow soldering (Whole device dipping)

It is recommended that flow soldering should be at 270°C or less for 10 s or less
(Pre-heating : 100 to 150°C, 30 to 80s). (2 times or less)

(2) If solder reflow :

It is recommended to be done at the temperature and the time within the temperature profile as shown in the figure below. (2 times or less)

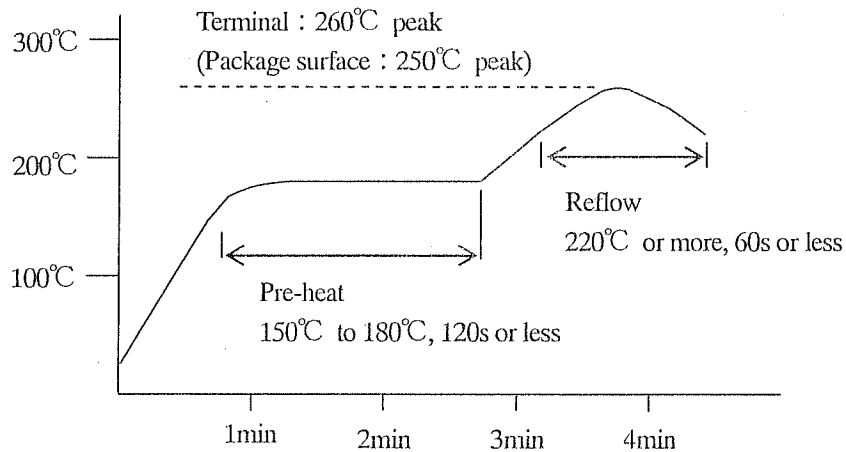

(3) In the case of hand soldering

What is done on the following condition is recommended.(2 times or less)

Soldering iron temperature : 400°C or less

Time : 3s or less

(4) Other precaution

Depending on equipment and soldering conditions (temperature, Using solder etc.), the effect to the device and the PCB is different.

Please confirm that there is no problem on the actual use conditions in advance.