

**VSC8486-04 Datasheet**  
**10 Gbps XAUI or XGMII to XFI LAN/WAN Transceiver**



---

a  **MICROCHIP** company



**Microsemi Headquarters**

One Enterprise, Aliso Viejo,  
CA 92656 USA

Within the USA: +1 (800) 713-4113

Outside the USA: +1 (949) 380-6100

Sales: +1 (949) 380-6136

Fax: +1 (949) 215-4996

Email: [sales.support@microsemi.com](mailto:sales.support@microsemi.com)

[www.microsemi.com](http://www.microsemi.com)

©2018 Microsemi, a wholly owned subsidiary of Microchip Technology Inc. All rights reserved. Microsemi and the Microsemi logo are registered trademarks of Microsemi Corporation. All other trademarks and service marks are the property of their respective owners.

Microsemi makes no warranty, representation, or guarantee regarding the information contained herein or the suitability of its products and services for any particular purpose, nor does Microsemi assume any liability whatsoever arising out of the application or use of any product or circuit. The products sold hereunder and any other products sold by Microsemi have been subject to limited testing and should not be used in conjunction with mission-critical equipment or applications. Any performance specifications are believed to be reliable but are not verified, and Buyer must conduct and complete all performance and other testing of the products, alone and together with, or installed in, any end-products. Buyer shall not rely on any data and performance specifications or parameters provided by Microsemi. It is the Buyer's responsibility to independently determine suitability of any products and to test and verify the same. The information provided by Microsemi hereunder is provided "as is, where is" and with all faults, and the entire risk associated with such information is entirely with the Buyer. Microsemi does not grant, explicitly or implicitly, to any party any patent rights, licenses, or any other IP rights, whether with regard to such information itself or anything described by such information. Information provided in this document is proprietary to Microsemi, and Microsemi reserves the right to make any changes to the information in this document or to any products and services at any time without notice.

**About Microsemi**

Microsemi, a wholly owned subsidiary of Microchip Technology Inc. (Nasdaq: MCHP), offers a comprehensive portfolio of semiconductor and system solutions for aerospace & defense, communications, data center and industrial markets. Products include high-performance and radiation-hardened analog mixed-signal integrated circuits, FPGAs, SoCs and ASICs; power management products; timing and synchronization devices and precise time solutions, setting the world's standard for time; voice processing devices; RF solutions; discrete components; enterprise storage and communication solutions, security technologies and scalable anti-tamper products; Ethernet solutions; Power-over-Ethernet ICs and midspans; as well as custom design capabilities and services. Learn more at [www.microsemi.com](http://www.microsemi.com).

# Contents

<b>1</b>	<b>Revision History</b>	<b>1</b>
1.1	Revision 4.4	1
1.2	Revision 4.3	1
1.3	Revision 4.2	1
1.4	Revision 4.1	1
1.5	Revision 4.0	1
1.6	Revision 2.0	1
<b>2</b>	<b>Product Overview</b>	<b>2</b>
2.1	Features	2
2.1.1	Low Power	2
2.1.2	Wide Range of Support	2
2.1.3	Tools for Rapid Design	2
2.1.4	Flexibility	3
<b>3</b>	<b>Functional Descriptions</b>	<b>4</b>
3.1	Operating Modes	4
3.1.1	XAUI to XFI Mode	5
3.1.2	XGMII to XFI Mode	7
3.2	Loopback	8
3.2.1	Input/Output Mode Select and XGMII Mode	10
3.2.2	Loopback Modes	11
3.3	Loopback Paths	13
3.3.1	Loopback A	13
3.3.2	Loopback B	14
3.3.3	Loopback C	14
3.3.4	Loopback D	15
3.3.5	Loopback E	15
3.3.6	Loopback F	16
3.3.7	Loopback G	16
3.3.8	Loopback H	17
3.3.9	Loopback J	17
3.3.10	Loopback K	17
3.3.11	XAUI Split Loopbacks B and D	18
3.3.12	PMA Split Loopbacks J and K	18
3.4	Physical Media Attachment	19
3.4.1	Multiplexer Operation	19
3.4.2	Timing Operation	20
3.4.3	Reference Clock Rate Selection	20
3.4.4	WAN Mode	20
3.4.5	Clock Multiplier Unit Reference Clocking	21
3.4.6	Reference Clock Inputs	22
3.4.7	External Capacitors	24
3.4.8	XFI Transmit Data CML Output	24
3.4.9	XFI Transmitter Pre-emphasis and Slew Rate	25
3.4.10	Line Rate Divided Clock Outputs	27
3.4.11	External Phase Lock Loop	28
3.4.12	High-Speed Serial Data Inputs	29
3.4.13	XFI Data Input Receiver Equalization	30
3.4.14	Loss of Signal	31
3.4.15	Loss of Optical Carrier	32

3.5	WAN Interface Sublayer	32
3.5.1	Operation	33
3.5.2	Section Overhead	35
3.5.3	Line Overhead	40
3.5.4	Pointer	45
3.5.5	Path Overhead	48
3.5.6	Reading Statistical Counters	52
3.5.7	Defects and Anomalies	53
3.5.8	Interrupt and Interrupt Masking	55
3.5.9	Overhead Serial Interfaces	55
3.5.10	Pattern Generator and Checker	59
3.5.11	Protocol Implementation Conformance Statement	59
3.6	Physical Coding Sublayer	59
3.6.1	Control Codes	60
3.6.2	Transmit Path	61
3.6.3	Receive Path	61
3.6.4	PCS Test Modes	62
3.7	Extended Physical Coding Sublayer	63
3.7.1	Autonegotiation	63
3.7.2	Frame Format	64
3.7.3	Link State Machines	64
3.7.4	FEC Controls and Feedback	65
3.7.5	Supervisory Channel	65
3.8	XGMII Extender Sublayer	66
3.8.1	XAUI Receiver	66
3.8.2	XAUI Loss of Signal	66
3.8.3	XAUI Receiver Equalization	67
3.8.4	XAUI Clock and Data Recovery	68
3.8.5	XAUI Code Group Synchronization	68
3.8.6	XAUI Lane Deskew	68
3.8.7	10b/8b Decoder	69
3.8.8	8b/10b Encoder and Serializer	69
3.8.9	XAUI Transmitter	69
3.8.10	XAUI Transmitter Pre-Emphasis	69
3.8.11	XAUI Transmitter Programmable-Output Swing	70
3.8.12	XGMII Tx Input Interface	70
3.8.13	XGMII Rx Output Interface	71
3.9	MDIO Serial Interface	72
3.9.1	MDIO Interface Operation	72
3.10	Two-Wire Serial Interface	75
3.10.1	Two-Wire Serial Controller	76
3.10.2	Automatic Mode	78
3.11	XFP or SFP+ Module Interface	79
3.11.1	General Purpose and LED Driver Outputs	81
3.12	JTAG Access Port	82
3.12.1	Instruction Register	86
3.12.2	Device ID Register	88
3.12.3	Bypass Register	88
3.12.4	Boundary Scan Register	88
3.13	Synchronous Ethernet	90
3.13.1	About Conventional Mode	90
3.13.2	Using Conventional Mode	91
3.13.3	About Enhanced Mode	92
3.13.4	Using Enhanced Mode	94
<b>4</b>	<b>Registers</b>	<b>96</b>
4.1	Device 1: PMA Registers	96

4.2	Device 2: WIS Registers .....	115
4.3	Device 3: PCS Registers .....	153
4.4	Device 4: PHY-XS Registers .....	166
4.5	Device 30: NVR and DOM Registers .....	179
<b>5</b>	<b>Electrical Specifications .....</b>	<b>188</b>
5.1	DC Characteristics .....	188
5.1.1	LVTTTL Inputs and Outputs .....	188
5.1.2	Reference Clock .....	188
5.1.3	MDIO Interface .....	189
5.2	AC Characteristics .....	189
5.2.1	10-Gigabit Inputs and Outputs .....	189
5.2.2	XAUI Inputs and Outputs .....	196
5.2.3	XGMII Specifications .....	198
5.2.4	Timing and Reference Clock .....	199
5.3	Operating Conditions .....	200
5.4	Stress Ratings .....	201
<b>6</b>	<b>Pin Descriptions .....</b>	<b>203</b>
6.1	Pin Diagram .....	203
6.2	Pins by Function .....	203
6.2.1	XFI 10-Gigabit Data Bus Interface .....	204
6.2.2	XAUI 10-Gigabit Data Bus Interface .....	204
6.2.3	XGMII 10-Gigabit Data Bus Interface .....	205
6.2.4	Serial Bus Interface .....	207
6.2.5	Input and Output Reference Clocks .....	208
6.2.6	Status and Control .....	209
6.2.7	Phase Detector Outputs .....	210
6.2.8	Phase-Locked Loop Filter Capacitors .....	211
6.2.9	JTAG Interface .....	211
6.2.10	Power and Ground .....	211
6.2.11	Miscellaneous Pins .....	213
<b>7</b>	<b>Package Information .....</b>	<b>214</b>
7.1	Package Drawing .....	214
7.1.1	Thermal Specifications .....	217
7.1.2	Moisture Sensitivity .....	217
<b>8</b>	<b>Design Guidelines .....</b>	<b>218</b>
8.1	Power Supply Connection .....	218
<b>9</b>	<b>Ordering Information .....</b>	<b>221</b>

# Figures

Figure 1	Functional Block Diagram	5
Figure 2	XAUI to XFI Mode Functional Diagram	6
Figure 3	XGMII to XFI Mode Functional Diagram	8
Figure 4	Loopback Configuration	9
Figure 5	Data Path XGMII Source	10
Figure 6	PHY XS Deep Network Loopback	14
Figure 7	PHY XS Shallow System Loopback	14
Figure 8	PHY XS Deep System Loopback	15
Figure 9	PHY XS Shallow Network Loopback	15
Figure 10	PCS FIFO System Loopback	16
Figure 11	Gearbox Network Loopback	16
Figure 12	PCS System Loopback G	16
Figure 13	PCS System Loopback H	17
Figure 14	PMA/WIS System Loopback	17
Figure 15	PMA Network Loopback	18
Figure 16	XAUI Split Loopback	18
Figure 17	PMA Split Loopback	19
Figure 18	PMA Block Diagram	19
Figure 19	Reference Clock Input Receiver	24
Figure 20	CML XFI Output Driver	25
Figure 21	XFI Data Transmitter Differential Voltage with Pre-emphasis	26
Figure 22	SONET Jitter-Compliant Reference Clock Configuration	28
Figure 23	Example External PLL Schematic Diagram	29
Figure 24	CML XFI Data Receiver	30
Figure 25	PMA LOS Functional Block Diagram	31
Figure 26	WIS Transmit and Receive Functions	33
Figure 27	WIS Frame Structure	34
Figure 28	STS-192c/STM-64 Section and Line Overhead Structure	34
Figure 29	Path Overhead Octets	35
Figure 30	Primary Synchronization State Diagram	36
Figure 31	Secondary Synchronization State Diagram	37
Figure 32	16-bit Designations within Payload Pointer	45
Figure 33	Pointer Interpreter State Diagram	47
Figure 34	Path Status (G1) Byte for ERDI_RDIN = 0	50
Figure 35	Path Status (G1) Byte for ERDI_RDIN = 1	50
Figure 36	TOSI Timing Diagram	56
Figure 37	ROSI Timing Diagram	59
Figure 38	PCS Block Diagram	60
Figure 39	64b/66b Block Formats	62
Figure 40	E-PCS Frame Format	64
Figure 41	E-PCS Framing State Diagram	65
Figure 42	XAUI Input Simplified Schematic	66
Figure 43	LOS State Diagram	68
Figure 44	LOA State Diagram	69
Figure 45	XAUI Output Differential Voltage with Pre-emphasis	70
Figure 46	XGMII Input Simplified Schematic	71
Figure 47	XGMII Output Structure and Termination	72
Figure 48	MDIO Frame Format	74
Figure 49	Timing with MDIO Sourced by STA	74
Figure 50	Timing with MDIO Sourced by MMD	75
Figure 51	Serial Management Interface	76
Figure 52	Two-Wire Serial Access State Diagram	78
Figure 53	VSC8486-04 to XFP Host Recommended Interface Connections	79
Figure 54	VSC8486-04 to SFP+ Host Recommended Interface Connections	80

Figure 55	Interrupt/Status/Activity LED Connections	81
Figure 56	JTAG TAP Boundary Scan Test Architecture	84
Figure 57	TAP Controller State Diagram	85
Figure 58	Clock Path Distribution, Conventional Mode	91
Figure 59	Synchronous Ethernet Block Diagram	94
Figure 60	Clock Path Distribution, Enhanced Mode	95
Figure 61	10-Gigabit Data Input Compliance Mask	190
Figure 62	Datacom Sinusoidal Jitter Tolerance	191
Figure 63	10-Gigabit Data Output Compliance Mask	195
Figure 64	XAUI Receiver Input Sinusoidal Jitter Tolerance	196
Figure 65	XAUI Output Compliance Mask	198
Figure 66	XGMII Input/Output Level Reference Diagram	198
Figure 67	XGMII Interface Timing Diagram	199
Figure 68	Parametric Measurement Setup	200
Figure 69	Timing with MDIO Sourced by STA	200
Figure 70	Timing with MDIO Sourced by MMD	200
Figure 71	Pin Diagram	203
Figure 72	Package Drawing for VSC8486SN-04 and VSC8486XSN-04	215
Figure 73	Package Drawing for VSC8486YSN-04	216
Figure 74	Recommended Power Supply Isolation Schematic	219
Figure 75	Split Plane Layout Example	219
Figure 76	Decoupling Capacitor Placement Example	220

# Tables

Table 1	Pin Control for XGMII After Reset	10
Table 2	MDIO Control for XGMII	11
Table 3	System Loopback Summary	11
Table 4	System Loopback and XFI Traffic	12
Table 5	Network Loopbacks Summary	12
Table 6	Split Loopbacks Summary	13
Table 7	Retiming Clock Sources for Network and Split Loopbacks	13
Table 8	REFSELO_STATUS Logic	20
Table 9	WAN Mode Control Logic	20
Table 10	CMU and CRU Reference Clock Control and Frequency Summary	21
Table 11	LAN/SAN Configuration	22
Table 12	SONET/SDH Jitter Generation-Compliant Configuration	22
Table 13	Non-SONET/SDH Jitter Generation-Compliant Configuration	23
Table 14	SONET/SDH Jitter-Compliant Configuration	23
Table 15	XFI Transmitter Pre-emphasis Ratio	26
Table 16	CLK64AP/N Clock Output	27
Table 17	CLK64BP/N Clock Output	27
Table 18	Register 1x8002.14:11 RXINP/N Equalization Control	31
Table 19	PMA LOS Register Status and Control Summary	32
Table 20	Section Overhead	35
Table 21	Framing Parameter Description and Values	37
Table 22	Line Overhead Octets	41
Table 23	K2 Encodings	43
Table 24	H1/H2 Pointer Types	46
Table 25	Concatenation Indication Types	46
Table 26	Pointer Interpreter State Diagram Transitions	47
Table 27	STS Path Overhead Octets	48
Table 28	RDI-P and ERDI-P Bit Settings and Interpretation	51
Table 29	PMTICK Counters	53
Table 30	Defects and Anomalies	53
Table 31	TOSI/ROSI Addresses	56
Table 32	Control Codes	60
Table 33	E-PCS Logic	64
Table 34	XAUI Lane LOS Threshold Summary	67
Table 35	XAUI Receiver Lane Equalization Setting	67
Table 36	XAUI Transmitter Lane Pre-emphasis Setting	70
Table 37	MDIO-Manageable Device Addresses	72
Table 38	Management Frame Format for Indirect Register Access	73
Table 39	XFP or SFP+ Host Application Pin Connections Summary	80
Table 40	GPO Configuration Control Summary	82
Table 41	JTAG TTL Signals	83
Table 42	TAP Controller States	85
Table 43	Supported Boundary Scan Test Instructions	87
Table 44	Boundary Scan Test Instruction Descriptions	87
Table 45	Device Identification Information	88
Table 46	Boundary Scan Register Bits	88
Table 47	Synchronous Ethernet Reference Clock Source	92
Table 48	Synchronous Ethernet Register Bits	93
Table 49	PMA_CTRL1: PMA Control 1 (1x0000)	96
Table 50	PMA_STAT1: PMA Status 1 (1x0001)	97
Table 51	PMA_DEVID1: PMA Device Identifier 1 (1x0002)	97
Table 52	PMA_DEVID2: PMA Device Identifier 2 (1x0003)	98
Table 53	PMA_SPEED: PMA Speed Capability (1x0004)	98
Table 54	PMA_DEVPKG1: PMA Devices in Package 1 (1x0005)	98



Table 55	PMA_DEVPKG2: PMA Devices in Package 2 (1×0006)	99
Table 56	PMA_CTRL2: PMA Control 2 (1×0007)	99
Table 57	PMA_STAT2: PMA Status 2 (1×0008)	99
Table 58	PMA_CTRL3: PMA Control 3 (1×0009)	101
Table 59	PMA_STAT3: PMA Status 3 (1×000A)	101
Table 60	Factory Test Register (1×000B-000D)	101
Table 61	PMA_PKGID1: PMA Package Identifier 1 (1×000E)	101
Table 62	PMA_PKGID2: PMA Package Identifier 2 (1×000F)	102
Table 63	PMA_CFG1: PMA Configuration 1 (1×8000)	102
Table 64	Factory Test Register (1×8001)	103
Table 65	PMA_RXEQ_CTRL: PMA Rx Equalization Control (1×8002)	103
Table 66	PMA_STAT4: PMA Status 4 (1×E600)	103
Table 67	PMA_CTRL4: PMA Control 4 (1×E601)	104
Table 68	PMA_CTRL5: PMA Control 5 (1×E602)	104
Table 69	High-Speed Data Output (Signal Quality Control) (1×E603)	105
Table 70	Synchronous Ethernet Clock Control (1×E604)	106
Table 71	DEV_CTRL3: DEVICE Control 3 (1×E605)	106
Table 72	DEV_STAT1: DEVICE Status 1 (1×E606)	108
Table 73	DEV_STAT2: DEVICE Status 2 (1×E607)	109
Table 74	PMA_LOS_ASSERT: PMA Loss of Signal Assert Control (1×E700)	110
Table 75	PMA_LOS_DEASSERT: PMA Loss of Signal Deassert Control (1×E701)	110
Table 76	PMA_LOS_STAT: PMA Loss of Signal Status (1×E702)	110
Table 77	DEV_ID: DEVICE Identifier (1×E800)	111
Table 78	DEV_REV: DEVICE Revision (1×E801)	111
Table 79	Factory Test Register (1×E900)	111
Table 80	DEV_GPIO_CTRL: DEVICE General Purpose I/O Control (1×E901)	111
Table 81	DEV_XFP_CTRL: DEVICE XFP Control (1×E902)	112
Table 82	Factory Test Register (1×EC00)	113
Table 83	Factory Test (1×EC01–EC34)	113
Table 84	Factory Test (1×ED00–ED0F)	113
Table 85	Factory Test Register (1×EF00)	113
Table 86	DEV_RST_CTRL: DEVICE Block Reset Control (1×EF01)	114
Table 87	DEV_XFI_CTRL2: DEVICE XFI Loopback Control 2 (1×EF10)	114
Table 88	WIS_CTRL1: WIS Control 1 (2×0000)	115
Table 89	WIS_STAT1: WIS Status 1 (2×0001)	115
Table 90	WIS_DEVID1: WIS Device Identifier 1 (2×0002)	116
Table 91	WIS_DEVID2: WIS Device Identifier 2 (2×0003)	116
Table 92	WIS_SPEED: WIS Speed Capability (2×0004)	116
Table 93	WIS_DEVPKG1: WIS Devices in Package 1 (2×0005)	117
Table 94	WIS_DEVPKG2: WIS Devices in Package 2 (2×0006)	117
Table 95	WIS_CTRL2: WIS Control 2 (2×0007)	117
Table 96	WIS_STAT2: WIS Status 2 (2×0008)	118
Table 97	WIS_TSTPAT_CNT: WIS Test Pattern Error Counter (2×0009)	119
Table 98	WIS_PKGID1: WIS Package Identifier 1 (2×000E)	119
Table 99	WIS_PKGID2: WIS Package Identifier 2 (2×000F)	119
Table 100	WIS_STAT3: WIS Status 3 (2×0021)	119
Table 101	WIS_REI_CNT: WIS Far-End Path Block Error Count (2×0025)	120
Table 102	WIS_TXJ1: WIS Tx J1s (2×0027-002E)	120
Table 103	WIS_RXJ1: WIS Rx J1s (2×002F-0036)	121
Table 104	WIS_REIL_CNT1: WIS Far-End Line BIP Errors 1 (2×0037)	121
Table 105	WIS_REIL_CNT0: WIS Far-End Line BIP Errors 0 (2×0038)	121
Table 106	WIS_B2_CNT1: WIS L-BIP Error Count 1 (2×0039)	121
Table 107	WIS_B2_CNT0: WIS L-BIP Error Count 0 (2×003A)	122
Table 108	WIS_B3_CNT: WIS P-BIP Block Error Count (2×003B)	122
Table 109	WIS_B1_CNT: WIS S-BIP Error Count (2×003C)	122
Table 110	WIS_TXJ0: WIS Transmit J0s (2×0040-0047)	122
Table 111	WIS_RXJ0: WIS Rx J0s (2×0048-004F)	122
Table 112	EWIS_TXCTRL1: WIS Vendor-Specific Tx Control 1 (2×E600)	123
Table 113	Factory Test Register (2×E601)	124

Table 114	Factory Test Register (2×E602)	124
Table 115	Factory Test Register (2×E603)	124
Table 116	Factory Test Register (2×E604)	124
Table 117	Factory Test Register (2×E605)	124
Table 118	EWIS_TX_A1_A2: E-WIS Tx A1/A2 Octets (2×E611)	125
Table 119	EWIS_TX_Z0_E1: E-WIS Tx Z0/E1 Octets (2×E612)	125
Table 120	EWIS_TX_F1_D1: E-WIS Tx F1/D1 Octets (2×E613)	125
Table 121	EWIS_TX_D2_D3: E-WIS Tx D2/D3 Octets (2×E614)	125
Table 122	EWIS_TX_C2_H1: E-WIS Tx C2/H1 Octets (2×E615)	125
Table 123	EWIS_TX_H2_H3: E-WIS Tx H2/H3 Octets (2×E616)	126
Table 124	EWIS_TX_G1_K1: E-WIS Tx G1/K1 Octets (2×E617)	126
Table 125	EWIS_TX_K2_F2: E-WIS Tx K2/F2 Octets (2×E618)	126
Table 126	EWIS_TX_D4_D5: E-WIS Tx D4/D5 Octets (2×E619)	126
Table 127	EWIS_TX_D6_H4: E-WIS Tx D6/H4 Octets (2×E61A)	126
Table 128	EWIS_TX_D7_D8: E-WIS Tx D7/D8 Octets (2×E61B)	127
Table 129	EWIS_TX_D9_Z3: E-WIS Tx D9/Z3 Octets (2×E61C)	127
Table 130	EWIS_TX_D10_D11: E-WIS Tx D10/D11 Octets (2×E61D)	127
Table 131	EWIS_TX_D12_Z4: E-WIS Tx D12/Z4 Octets (2×E61E)	127
Table 132	EWIS_TX_S1_Z1: E-WIS Tx S1/Z1 Octets (2×E61F)	127
Table 133	EWIS_TX_Z2_E2: E-WIS Tx Z2/E2 Octets (2×E620)	128
Table 134	EWIS_TX_N1: E-WIS Tx N1 Octet (2×E621)	128
Table 135	Factory Test Register (2×E622)	128
Table 136	EWIS_TX_MSGLEN: E-WIS Tx Trace Message Length Control (2×E700)	128
Table 137	EWIS_TXJ0: E-WIS Tx J0s 16-63 (2×E800-E817)	128
Table 138	EWIS_RXJ0: E-WIS Rx J0s 16-63 (2×E900-E917)	129
Table 139	EWIS_TXJ1: E-WIS Tx J1s 16-63 (2×EA00-EA17)	129
Table 140	EWIS_RXJ1: E-WIS Rx J1s 16-63 (2×EB00-EB17)	129
Table 141	EWIS_RX_FRM_CTRL1: E-WIS Rx Framer Control 1 (2×EC00)	129
Table 142	EWIS_RX_FRM_CTRL2: E-WIS Rx Framer Control 2 (2×EC01)	130
Table 143	EWIS_LOF_CTRL1: E-WIS Loss of Frame Control 1 (2×EC02)	130
Table 144	EWIS_LOF_CTRL2: E-WIS Loss of Frame Control 2 (2×EC03)	131
Table 145	EWIS_RX_CTRL1: E-WIS Rx Control 1 (2×EC10)	131
Table 146	EWIS_RX_MSGLEN: E-WIS Rx Trace Message Length Control (2×EC20)	132
Table 147	EWIS_RX_ERR_FRC1: E-WIS Rx Error Force Control 1 (2×EC30)	132
Table 148	EWIS_RX_ERR_FRC2: E-WIS Rx Error Force Control 2 (2×EC31)	133
Table 149	EWIS_MODE_CTRL: E-WIS Mode Control (2×EC40)	135
Table 150	Factory Test Register (2×EC41)	135
Table 151	EWIS_PRBS31_ANA_CTRL: E-WIS PRBS31 Analyzer Control (2×EC50)	136
Table 152	EWIS_PRBS31_ANA_STAT: E-WIS PRBS31 Analyzer Status (2×EC51)	136
Table 153	EWIS_PMTICK_CTRL: E-WIS Performance Monitor Control (2×EC60)	137
Table 154	EWIS_CNT_CFG: E-WIS Counter Configuration (2×EC61)	137
Table 155	EWIS_CNT_STAT: E-WIS Counter Status (2×EC62)	138
Table 156	EWIS_REIP_CNT1: E-WIS P-REI Counter 1 (MSW) (2×EC80)	138
Table 157	EWIS_REIP_CNT0: E-WIS P-REI Counter 0 (LSW) (2×EC81)	139
Table 158	EWIS_REIL_CNT1: E-WIS L-REI Counter 1 (MSW) (2×EC90)	139
Table 159	EWIS_REIL_CNT0: E-WIS L-REI Counter 0 (LSW) (2×EC91)	139
Table 160	Factory Test Register (2×ECA0)	139
Table 161	EWIS_B1_ERR_CNT1: E-WIS S-BIP Error Counter 1 (MSW) (2×ECB0)	139
Table 162	EWIS_B1_ERR_CNT0: E-WIS S-BIP Error Counter 0 (LSW) (2×ECB1)	140
Table 163	EWIS_B2_ERR_CNT1: E-WIS L-BIP Error Counter 1 (MSW) (2×ECB2)	140
Table 164	EWIS_B2_ERR_CNT0: E-WIS L-BIP Error Counter 0 (LSW) (2×ECB3)	140
Table 165	EWIS_B3_ERR_CNT1: E-WIS P-BIP Error Counter 1 (MSW) (2×ECB4)	140
Table 166	EWIS_B3_ERR_CNT0: E-WIS P-BIP Error Counter 0 (LSW) (2×ECB5)	140
Table 167	Factory Test Register (2×ED00-ED08)	141
Table 168	EWIS_RXTX_CTRL: E-WIS Rx to Tx Control (2×EE00)	141
Table 169	EWIS_PEND1: E-WIS Interrupt Pending 1 (2×EF00)	142
Table 170	EWIS_MASKA_1: E-WIS Interrupt Mask A 1 (2×EF01)	144
Table 171	EWIS_MASKB_1: E-WIS Interrupt Mask B 1 (2×EF02)	145
Table 172	EWIS_INTR_STAT2: E-WIS Interrupt Status 2 (2×EF03)	146

Table 173	EWIS_INTR_PEND2: E-WIS Interrupt Pending 2 (2×EF04)	147
Table 174	EWIS_INTR_MASKA2: E-WIS Interrupt Mask A 2 (2×EF05)	149
Table 175	EWIS_INTR_MASKB2: E-WIS Interrupt Mask B 2 (2×EF06)	151
Table 176	WIS Fault Control (2×EF07)	152
Table 177	PCS_CTRL1: PCS Control 1 (3×0000)	153
Table 178	PCS_STAT1: PCS Status 1 (3×0001)	154
Table 179	PCS_DEVID1: PCS Device Identifier 1 (3×0002)	154
Table 180	PCS_DEVID2: PCS Device Identifier 2 (3×0003)	154
Table 181	PCS_SPEED: PCS Speed Capability (3×0004)	154
Table 182	PCS_DEVPKG1: PCS Devices in Package 1 (3×0005)	155
Table 183	PCS_DEVPKG2: PCS Devices in Package 2 (3×0006)	155
Table 184	PCS_CTRL2: PCS Control 2 (3×0007)	155
Table 185	PCS_STAT2: PCS Status 2 (3×0008)	156
Table 186	PCS_PKGID1: PCS Package Identifier 1 (3×000E)	156
Table 187	PCS_PKGID2: PCS Package Identifier 2 (3×000F)	157
Table 188	PCS_10GBASEX_STAT: PCS 10G BASE-X Status (3×0018)	157
Table 189	PCS_10GBASEX_CTRL: PCS 10G BASE-X Control (3×0019)	157
Table 190	PCS_10GBASER_STAT1: PCS 10G BASE-R Status 1 (3×0020)	157
Table 191	PCS_10GBASER_STAT2: PCS 10G BASE-R Status 2 (3×0021)	158
Table 192	PCS_SEEDA3: PCS Test Pattern Seed A 3 (3×0022)	158
Table 193	PCS_SEEDA2: PCS Test Pattern Seed A 2 (3×0023)	158
Table 194	PCS_SEEDA1: PCS Test Pattern Seed A 1 (3×0024)	158
Table 195	PCS_SEEDA0: PCS Test Pattern Seed A 0 (3×0025)	158
Table 196	PCS_SEEDB3: PCS Test Pattern Seed B 3 (3×0026)	159
Table 197	PCS_SEEDB2: PCS Test Pattern Seed B 2 (3×0027)	159
Table 198	PCS_SEEDB1: PCS Test Pattern Seed B 1 (3×0028)	159
Table 199	PCS_SEEDB0: PCS Test Pattern Seed B 0 (3×0029)	159
Table 200	PCS_TSTPAT_CTRL: PCS Test Pattern Control (3×002A)	159
Table 201	PCS_TSTPAT_CNT: PCS Test Pattern Error Counter (3×002B)	160
Table 202	PCS_USRPAT0: PCS User Test Pattern 0 (3×8000)	160
Table 203	PCS_USRPAT1: PCS User Test Pattern 1 (3×8001)	160
Table 204	PCS_USRPAT2: PCS User Test Pattern 2 (3×8002)	160
Table 205	PCS_USRPAT3: PCS User Test Pattern 3 (3×8003)	161
Table 206	PCS_SQPW_CTRL: PCS Square Wave Pulse Width Control (3×8004)	161
Table 207	PCS_CFG1: PCS Configuration 1 (3×8005)	161
Table 208	PCS_ERR_CNT0: PCS Test Error Counter 0 (3×8007)	162
Table 209	PCS_ERR_CNT1: PCS Test Error Counter 1 (3×8008)	162
Table 210	Factory Test Register (3×8009)	162
Table 211	Factory Test Register (3×800C)	162
Table 212	Factory Test Register (3×800D)	162
Table 213	Factory Test Register (3×800E)	163
Table 214	Factory Test Register (3×800F)	163
Table 215	Factory Test Register (3×8010)	163
Table 216	Factory Test Register (3×8011)	163
Table 217	Factory Test Register (3×8012)	163
Table 218	Factory Test Register (3×8013)	163
Table 219	Factory Test Register (3×8014)	163
Table 220	Factory Test Register (3×8015)	163
Table 221	PCS_CFG2: PCS Configuration 2 (3×E600)	164
Table 222	Factory Test Register (3×E601)	164
Table 223	Factory Test Register (3×E602)	164
Table 224	Factory Test Register (3×E603)	164
Table 225	EPCS_STAT1: E-PCS Status 1 (3×E604)	164
Table 226	EPCS_CORR_CNT: E-PCS Corrected FEC Error Counter (3×E605)	165
Table 227	EPCS_UCORR_CNT: E-PCS Uncorrected FEC Error Counter (3×E606)	165
Table 228	EPCS_TXMSG: E-PCS Tx Message (3×E60A-E611)	165
Table 229	EPCS_RXMSG: E-PCS Rx Message (3×E612-E619)	165
Table 230	Factory Test Register (3×E61A)	166
Table 231	Factory Test Register (3×E61B)	166

Table 232	Factory Test Register (3×E61C) . . . . .	166
Table 233	Factory Test Register (3×E61D) . . . . .	166
Table 234	PHYXS_CTRL1: PHY XS Control 1 (4×0000) . . . . .	166
Table 235	PHYXS_STAT1: PHY XS Status1 (4×0001) . . . . .	167
Table 236	PHYXS_DEVID1: PHY XS Device Identifier 1 (4×0002) . . . . .	167
Table 237	PHYXS_DEVID2: PHY XS Device Identifier 2 (4×0003) . . . . .	168
Table 238	PHYXS_SPEED: PHY XS Speed Capability (4×0004) . . . . .	168
Table 239	PHYXS_DEVPKG1: PHY XS Devices in Package 1 (4×0005) . . . . .	168
Table 240	PHYXS_DEVPKG2: PHY XS Devices in Package 2 (4×0006) . . . . .	169
Table 241	PHYXS_STAT2: PHY XS Status 2 (4×0008) . . . . .	169
Table 242	PHYXS_STAT3: PHY XS Status 3 (4×0018) . . . . .	169
Table 243	PHYXS_TSTCTRL1: PHY XGXS Test Control 1 (4×0019) . . . . .	170
Table 244	PHYXS_TSTCTRL2: PHY XS Test Control 2 (4×8000) . . . . .	170
Table 245	PHYXS_TSTSTAT: PHY XS Test Pattern Check Status (4×8001) . . . . .	171
Table 246	Factory Test Register (4×8002) . . . . .	171
Table 247	Factory Test Register (LSW) (4×8003) . . . . .	171
Table 248	Factory Test Register (4×8004) . . . . .	172
Table 249	Factory Test Register (4×8005) . . . . .	172
Table 250	Factory Test Register (4×8006) . . . . .	172
Table 251	Factory Test Register (4×8007) . . . . .	172
Table 252	Factory Test Register (4×8008) . . . . .	172
Table 253	Factory Test Register (4×8009) . . . . .	172
Table 254	Factory Test Register (4×800A) . . . . .	172
Table 255	PHYXS_TPERR_CTRL: PHY XS Test Pattern Error Counter Control (4×800B) . . . . .	172
Table 256	PHYXS_TPERR_CNT0: PHY XS Test Pattern Error Counter 0 (LSW) (4×800C) . . . . .	173
Table 257	PHYXS_TPERR_CNT0: PHY XS Test Pattern Error Counter 1 (MSW) (4×800D) . . . . .	173
Table 258	PHYXS_XAUI_CTRL1: PHY XS XAUI Control 1 (4×800E) . . . . .	173
Table 259	PHYXS_XAUI_CTRL2: PHY XS XAUI Control 2 (4×800F) . . . . .	174
Table 260	PHYXS_RXEQ_CTRL: PHY XS XAUI Rx Equalization Control (4×8010) . . . . .	175
Table 261	PHYXS_TXPE_CTRL: PHY XS XAUI Tx Pre-emphasis Control (4×8011) . . . . .	175
Table 262	PHYXS_RXLOS_STAT: PHY XS Rx Loss of Signal Status (4×8012) . . . . .	176
Table 263	PHYXS_RXSD_STAT: PHY XS Rx Signal Detect Status (4×E600) . . . . .	176
Table 264	Factory Test Register (4×E601) . . . . .	177
Table 265	PHYXS_TXPD_CTRL: PHY XS XAUI Tx Power Down Control (4×E602) . . . . .	177
Table 266	PHYXS_RXPD_CTRL: PHY XS XAUI Rx Power Down Control (4×E603) . . . . .	178
Table 267	FC_CJPAT_SEL (4×E604) . . . . .	179
Table 268	Factory Test Register (4×E610) . . . . .	179
Table 269	STW_CTRL1: STW Control 1 (1E×8000) . . . . .	179
Table 270	STW_DEVADDR: STW Device Address (1E×8002) . . . . .	180
Table 271	STW_REGADDR: STW Register Address (1E×8003) . . . . .	180
Table 272	STW_CFG1: STW Configuration 1 (1E×8004) . . . . .	180
Table 273	NVR Memory Map (1E×8007-8106) . . . . .	181
Table 274	DOM_RXALRM_CTRL: DOM Rx Alarm Control (1E×9000) . . . . .	181
Table 275	DOM_TXALRM_CTRL: DOM Tx Alarm Control (1E×9001) . . . . .	181
Table 276	DOM_LASI_CTRL: DOM Link Alarm Status Interrupt Control (1E×9002) . . . . .	182
Table 277	DOM_RXALRM_STAT: DOM Rx Alarm Status (1E×9003) . . . . .	182
Table 278	DOM_TXALRM_STAT: DOM Tx Alarm Status (1E×9004) . . . . .	183
Table 279	DOM_LASI_STAT: DOM Link Alarm Status Interrupt Status (1E×9005) . . . . .	183
Table 280	DOM_TXFLAG_CTRL: DOM Tx Flag Control (1E×9006) . . . . .	183
Table 281	DOM_RXFLAG_CTRL: DOM Rx Flag Control (1E×9007) . . . . .	184
Table 282	Factory Test Register (1E×A000-A027) . . . . .	184
Table 283	Factory Test Register (1E×A048-A05F) . . . . .	184
Table 284	Factory Test Register (1E×A060-A06D) . . . . .	184
Table 285	Factory Test Register (1E×A06E) . . . . .	185
Table 286	Factory Test Register (1E×A06F) . . . . .	185
Table 287	DOM_TXALARM: DOM Tx Alarm Flags (1E×A070) . . . . .	185
Table 288	DOM_RXALARM: DOM Rx Alarm Flags (1E×A071) . . . . .	185
Table 289	Factory Test Register (1E×A072-A073) . . . . .	186
Table 290	DOM_TXWARN: DOM Tx Warning Flags (1E×A074) . . . . .	186

Table 291	DOM_RXWARN: DOM Rx Warning Flags (1E×A075)	186
Table 292	Factory Test Register (1E×A076-A077)	187
Table 293	Factory Test Register (1E×A0C0-A0FF)	187
Table 294	Factory Test Register (1E×A100)	187
Table 295	Factory Test Register (1E×A101-A106)	187
Table 296	LVTTTL I/O Specifications	188
Table 297	Reference Clock Input Specifications	189
Table 298	MDIO Interface Characteristics	189
Table 299	10-Gigabit Serial Data Input Specifications	189
Table 300	10-Gigabit Data Input Specifications for CRU	191
Table 301	10-Gigabit Data Output Specifications for MUX	193
Table 302	10-Gigabit Data Output Specifications for CMU, WAN Mode	193
Table 303	10-Gigabit Data Output Specifications for CMU, LAN/SAN Mode	194
Table 304	XAUI Input Specifications	196
Table 305	XAUI Output Specifications	197
Table 306	XGMII Input Specifications	198
Table 307	XGMII Output Specifications	199
Table 308	Reset Timing	199
Table 309	Reference Clock Specifications	199
Table 310	TXCLK and RXCLK Timing Parameters	199
Table 311	Recommended Operating Conditions	200
Table 312	Stress Ratings	201
Table 313	XFI 10-Gigabit Data Bus Pins	204
Table 314	XAUI 10-Gigabit Data Bus Pins	204
Table 315	XGMII 10-Gigabit Data Bus Pins	205
Table 316	Serial Bus Interface Pins	207
Table 317	Input and Output Reference Clock Pins	208
Table 318	Status and Control Pins	209
Table 319	Phase Detector Output Pins	210
Table 320	Phase-Locked Loop Filter Capacitor Pins	211
Table 321	JTAG Interface Pins	211
Table 322	Power and Ground Pins	211
Table 323	Miscellaneous	213
Table 324	Thermal Resistances	217
Table 325	Power Supply and Pin Locations	218
Table 326	Ordering Information	221

# 1 Revision History

---

This section describes the changes that were implemented in this document. The changes are listed by revision, starting with the most current publication.

## 1.1 Revision 4.4

In revision 4.4 of this document, the XAUI LOS signal information was clarified. For more information, see [Table 261](#), page 175 (bits 3:2) and [Table 262](#), page 176 (bits 3:0).

## 1.2 Revision 4.3

In revision 4.3 of this document, the lead-free (Pb-free) package, VSC8486YSN-04, was added.

## 1.3 Revision 4.2

The following is a summary of the changes in revision 4.2 of this document.

- Two-wire serial to SFP+/XFP manual mode of operation is not supported. The STW\_MODE register bit must be set to 0 for automatic mode of operation.
- Two-wire serial reset command register was clarified. It can only be used to reset the local two-wire serial circuit, not to reset downstream SFP+/XFP devices.

## 1.4 Revision 4.1

The following is a summary of the changes in revision 4.1 of this document.

- The recommended operating temperature was changed from 0 °C ambient to 85 °C case to –40 °C ambient to 95 °C case.
- The minimum reference clock frequency was changed from 156.25 MHz to 153 MHz.

## 1.5 Revision 4.0

The following is a summary of the changes in revision 4.0 of this document.

- Electrical specifications were updated based on final characterization results.
- XGMII to XAUI mode is not supported.
- The default value for the device revision number register 1×E801.15:0 was updated to 0×0004.
- The PCS configuration register bit settings for 3×E600.1:0 were modified.
- For applications that do not require high input gain, the synchronous Ethernet clock control register bit 1×E604.15 should be set to 1 for optimal jitter tolerance.
- The remote error indication (REI-P) status bit will be triggered in the event of an invalid REI-P value; however, the REI-P counter will not be incremented.

## 1.6 Revision 2.0

Revision 2.0 was the first publication of this document.

## 2 Product Overview

---

The VSC8486-04 is a LAN/WAN XAUI or XGMII transceiver that converts 3 Gbps XAUI data to a 10 Gbps serial stream. At just 840 mW, the VSC8486-04 is ideal for applications requiring low power. The device is also equipped with an additional full-rate data port that can be utilized for bypass monitoring or channel monitoring applications. The device meets all specifications for 10 Gigabit Ethernet (GbE) Layer-1 processing, as defined in IEEE 802.3ae.

The VSC8486-04 offers exceptional 10 Gbps mixed-signal performance with a data output that features programmable pre-emphasis to enable longer traces of copper. The VSC8486-04 high-speed serial I/O supports 9.9 Gbps, 10.3 Gbps, and 10.5 Gbps, as defined by IEEE 802.3ae and T11 10 GFC, and is fully compliant with the SONET jitter specification defined by Bellcore GR253.

There are four main data processing blocks in the device: XGXS, PCS, WIS, and PMA. The 10 GbE extender sublayer (XGXS) accepts 8b/10b data running at 3.125 Gbps and decodes it for transmission to the physical coding sublayer (PCS). The XGXS is capable of deskewing more than 60 bit times between lanes. The PCS receives data from the XGXS at 10 Gbps and encodes data according to the 64b/66b algorithm described in IEEE 802.3ae clause 49.

The PCS features an optional extended mode (E-PCS) that also runs at the 64b/66b rate. This extended mode uses an alternative framing algorithm that adds forward error correction (FEC) to provide ~2.5 dB of net electrical coding gain. The E-PCS is available for LAN mode but not WAN mode.

The PCS outputs data to the WAN interface sublayer (WIS) when this mode is active (it is bypassed in LAN mode). The WIS optionally takes data from the PCS at 9.953 Gbps and frames data in a SONET STS-192c frame, as described in IEEE 802.3ae clause 50. Additionally, the WIS block contains extended SONET and SDH processing capabilities that allow system operators to leverage valuable performance monitoring data. Finally, data is delivered to the physical media attachment (PMA) block. The PMA multiplexes the internal parallel data bus into a 10 Gbps data stream.

The 10 Gbps to XAUI data channel performs the operations described above in reverse. Notable features in this path are a SONET-compliant LOS detector and a 10 Gbps receiver that is fully compliant with XFI specifications, including stressed eye criteria.

The device operates using a 1.2 V supply dissipating only 750 mW in LAN mode and 840 mW in WAN mode. The VSC8486-04 device is available in lead-free (Pb-free) packages, measuring 17 mm × 17 mm with 256 pins and 1 mm pin pitch.

### 2.1 Features

The following list provides the features and benefits of the VSC8486-04 device.

#### 2.1.1 Low Power

- Exceptionally low power (750 mW LAN mode or 840 mW WAN mode) allows for higher port densities

#### 2.1.2 Wide Range of Support

- Fully compatible with IEEE 802.3ae and T11 10 GFC
- Extended-WIS (E-WIS) provides full Clause 50 support and enables transport over existing SONET networks
- 10 Gbps serial interface exceeds all SONET and 10 GbE requirements
- 4 × 3.125 Gbps and 3.182 Gbps XAUI I/O enable interconnection with a wide range of Layer-2 devices
- Seamless connectivity to XFP and SFP+ modules

#### 2.1.3 Tools for Rapid Design

- Multiple loopback modes and built-in self test (BIST) capabilities reduce system development costs, enable manufacturing tests, and improve time to market
- JTAG access port facilitates boundary scan for in-circuit test to improve board yield

- Single 1.2 voltage for the whole device with optional power supply range (1.2 V, 1.5 V, 1.8 V, or 3.3 V) for the TTL interface

## 2.1.4 Flexibility

- XAUI I/O programmability for lane swap, invert, amplitude, pre-emphasis, and equalization
- KX4-compatible 3 Gbps I/O for long-reach copper interconnect provides additional margin to traverse connectors and the backplane up to 40 inches
- Extended-PCS (E-PCS) mode with forward error correction (FEC) auto-negotiation allows extended reach over single-mode and multimode fiber with  $10^{-15}$  error floor
- On the 10-gigabit serial link, enhanced de-emphasis and equalization compensates for connector and channel losses and makes the device SFP+ compatible
- Accessibility of the recovered clock from high speed input and separate clock paths for CMU and CRU enable Layer 1 support for Synchronous Ethernet



## 3 Functional Descriptions

---

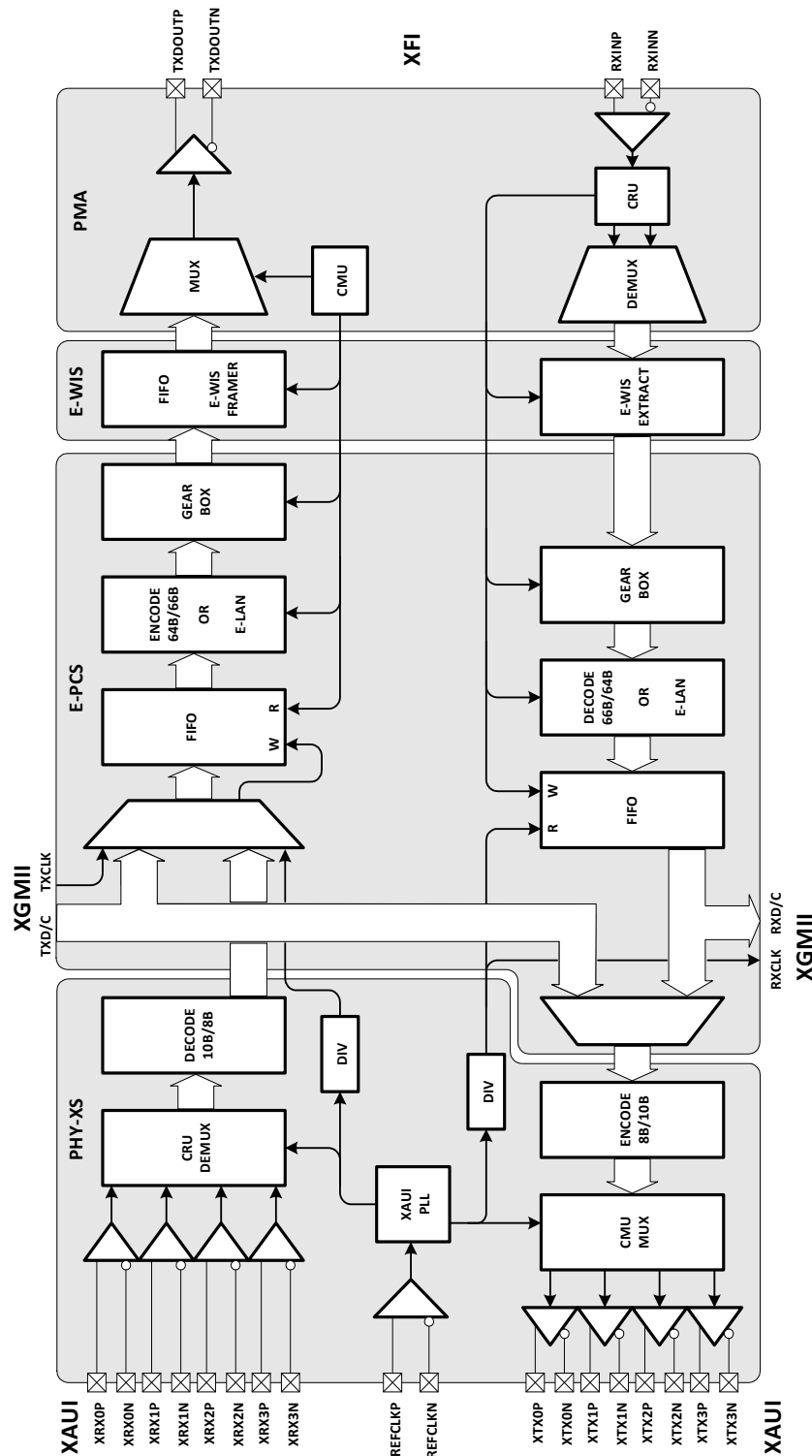
This section presents the functional description for the VSC8486-04 device. The main areas described are:

- Data paths
- Loopback options
- Implementation of the IEEE MDIO manageable devices (MMDs)
- Extended functionality for WIS and PCS
- Low-speed serial interfaces (MDIO, two-wire serial, and JTAG)

### 3.1 Operating Modes

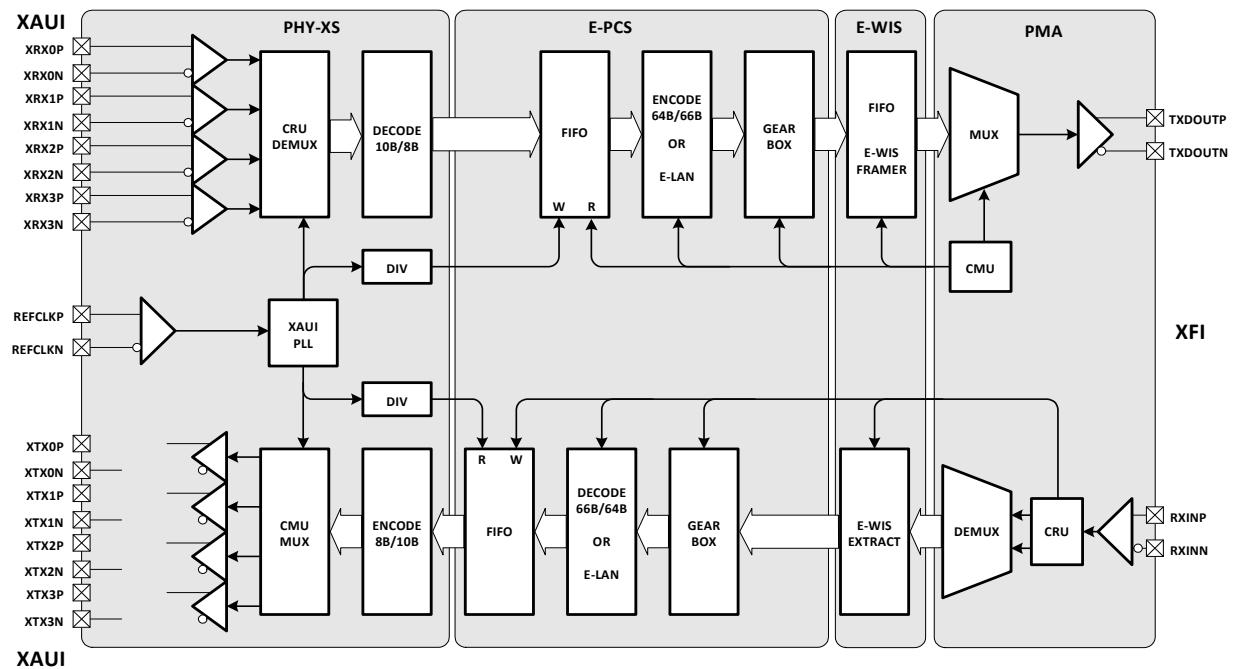
The following illustration shows the VSC8486-04 operations.

Figure 1 • Functional Block Diagram



### 3.1.1 XAUI to XFI Mode

To put the VSC8486-04 in the XAUI to XFI mode, set the I/O mode select pin high (IOMODESEL = 1). IOMODESEL sets the default value of XGMII\_OE (3×8005.6) and PCS\_XGMII\_SRC (3×8005.8).

**Figure 2 • XAUI to XFI Mode Functional Diagram**


### 3.1.1.1 Transmit Operation for XAUI to XFI Mode

As shown in the preceding illustration, the PHY XS block receives four 8b/10b encoded 3.125 Gbps (3.1875 Gbps in SAN mode) data lanes on pins XRX[3:0]P/N. The clock is recovered and the data is deserialized on each of the four lanes. Synchronization is performed before the data is passed into the 10b/8b decoders. The decoded data and accompanying control bits are then presented to the FIFO. The FIFO deskews the four lanes and presents the aligned data to the PCS.

The FIFO within the PCS transfers path timing from the PHY XS recovered clock to the PMA transmit clock by adding or deleting idle characters during inter-packet gaps (IPG) as needed. The eight data octets (8-bit characters) and eight control bits pass through the 64b/66b encoder, which maps XGMII data to a single 66-bit transmission block, as defined in Figure 49-7 of IEEE Standard 802.3ae.

In standard PCS mode (EPCS = 0), the first two bits of the 66-bit block contain the sync header, which is used to establish block boundaries for the synchronization process during the receive operation. The remaining 64 bits contain the payload. The payload passes through the scrambler, which implements the polynomial  $G(x) = 1 + x^{39} + x^{58}$ . The sync header bypasses the scrambler, and joins the scrambled payload at the 64:66 gearbox. The gearbox adapts between the 66-bit width of the blocks and the 64-bit width of the PMA or WIS interface.

In extended PCS mode (EPCS = 1), the 64 payload bits are mapped such that 24 instances of the 64-bit payloads are placed into a larger 1584-bit frame defined by the Optical Internetworking Forum (OIF) Common Electrical I/O Protocol (CEI-P). Each 64-bit payload is preceded by one transcoding bit, and the remaining 24 bits of the 1584-bit frame are used for synchronization, fire code parity check, supervisory channel, and to indicate the link state. This frame is then scrambled with a free-running linear feedback shift register (LFSR) scrambler with a characteristic polynomial  $G(x) = x^{17} + x^{14} + 1$ . The scrambled frame then passes through the 64:66 gearbox to the PMA or WIS.

In LAN or SAN mode (WAN\_STAT = 0), the PCS data is passed directly to the PMA, while in WAN mode (WAN\_STAT = 1), the PCS data is passed to the WIS. The WIS inserts the PCS data into SONET STS-192c/SDH STM-64 frames, and adds the required overhead.

Within the PMA, the data is serialized into the high-speed data stream (10.3125 Gbps in LAN mode, 10.51875 Gbps in SAN mode, and 9.95328 Gbps in WAN mode). The data stream and the divide-by-64 clock (161.13 MHz in LAN mode, 164.35 MHz in SAN mode, and 155.52 MHz in WAN mode) are provided for line transmission on pins TXDOUTP/N and CLK64AP/N, respectively.

### 3.1.1.2 Receive Operation for XAUI to XFI Mode

High-speed, 10 Gbps NRZ serial data is received on pins RXINP/N where it can be equalized for copper trace dispersion and presented to the clock recovery unit (CRU).

In LAN and SAN mode (WAN\_STAT = 0), the output of the CRU is deserialized and presented to the PCS, while in WAN mode (WAN\_STAT = 1), the output of the CRU is deserialized and presented to the WIS. The WIS extracts the data from the SONET STS-192c/SDH STM-64 frames and processes the overhead. The resultant data is then presented to the PCS.

In standard PCS mode (EPCS\_STAT = 0), the data enters the 66:64 gearbox. The 66-bit block is then aligned using the embedded 2-bit sync header, which generates the 64-bit payload. The payload is descrambled using the polynomial  $G(x) = 1 + x^{39} + x^{58}$ . The descrambled payload and 2-bit sync header pass through the 64b/66b decoder, where the block is mapped to valid XGMII data, eight data octets, and eight control bits.

In extended PCS mode (EPCS\_STAT = 1), the data enters the PCS and is presented to the 66:64 gearbox. The data is then descrambled, framed, and formatted into 1584-bit frames. The Fire Code parity check code in the received data stream is used to delineate frame boundaries. Because the scrambler bits are XOR'ed with the FEC overhead during transmission, the state of the scrambler can be recovered by subtracting the calculated parity from the received scrambled parity. The block is then mapped to valid XGMII data, eight data octets, and eight control bits.

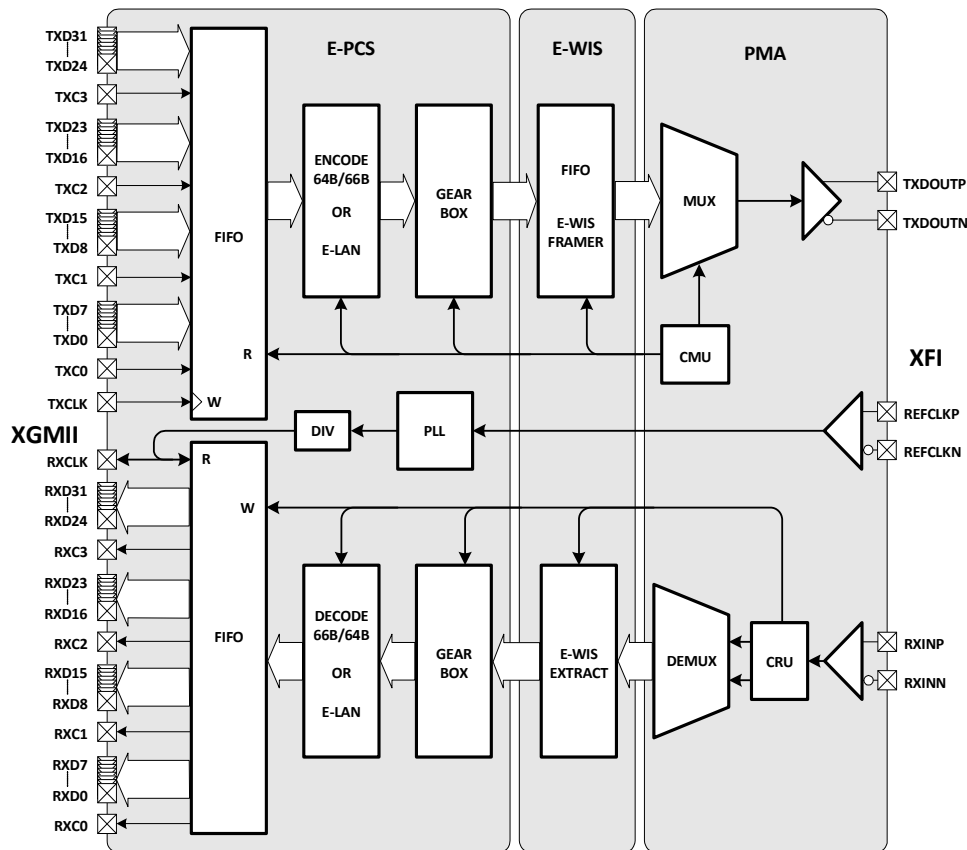
In both standard or extended PCS modes, the eight data octets and eight control bits are passed to the FIFO, where path timing is transferred from the divided (one sixty-fourth) recovered clock to the divided (one sixty-sixth) CMU clock. During IPG, idle characters are added or deleted as necessary to adapt between the two clock rates.

The eight data octets and eight control bits are then presented to the PHY XS block where it is 8b/10b encoded and serialized. The serialized code words are then transmitted four at a time on the four XAUI outputs:  $XTX[3:0]P/N$ .

### 3.1.2 XGMII to XFI Mode

To set the VSC8486-04 into the XGMII to XFI mode, the I/O mode select pin must be set low (IOMODESEL = 0). IOMODESEL sets the default value of XGMII\_OE (3×8005.6) and PCS\_XGMII\_SRC (3×8005.8) appropriately to a value of 0×0140 after a reset is executed. The following illustration shows the data path for this mode.

**Figure 3 • XGMII to XFI Mode Functional Diagram**



### 3.1.2.1 Transmit Operation for XGMII to XFI Mode

In XGMII to XFI mode, the XGXS (and XAUI input interface) is bypassed and the data is presented directly to the PCS from the XGMII interface. All other transmit functions are the same.

### 3.1.2.2 Receive Operation for XGMII to XFI Mode

In XGMII to XFI mode, the XGXS (and XAUI output interface) is bypassed and the data from the PCS is directly output from the device on the XGMII interface on RXD[31:0] and RxC[3:0].

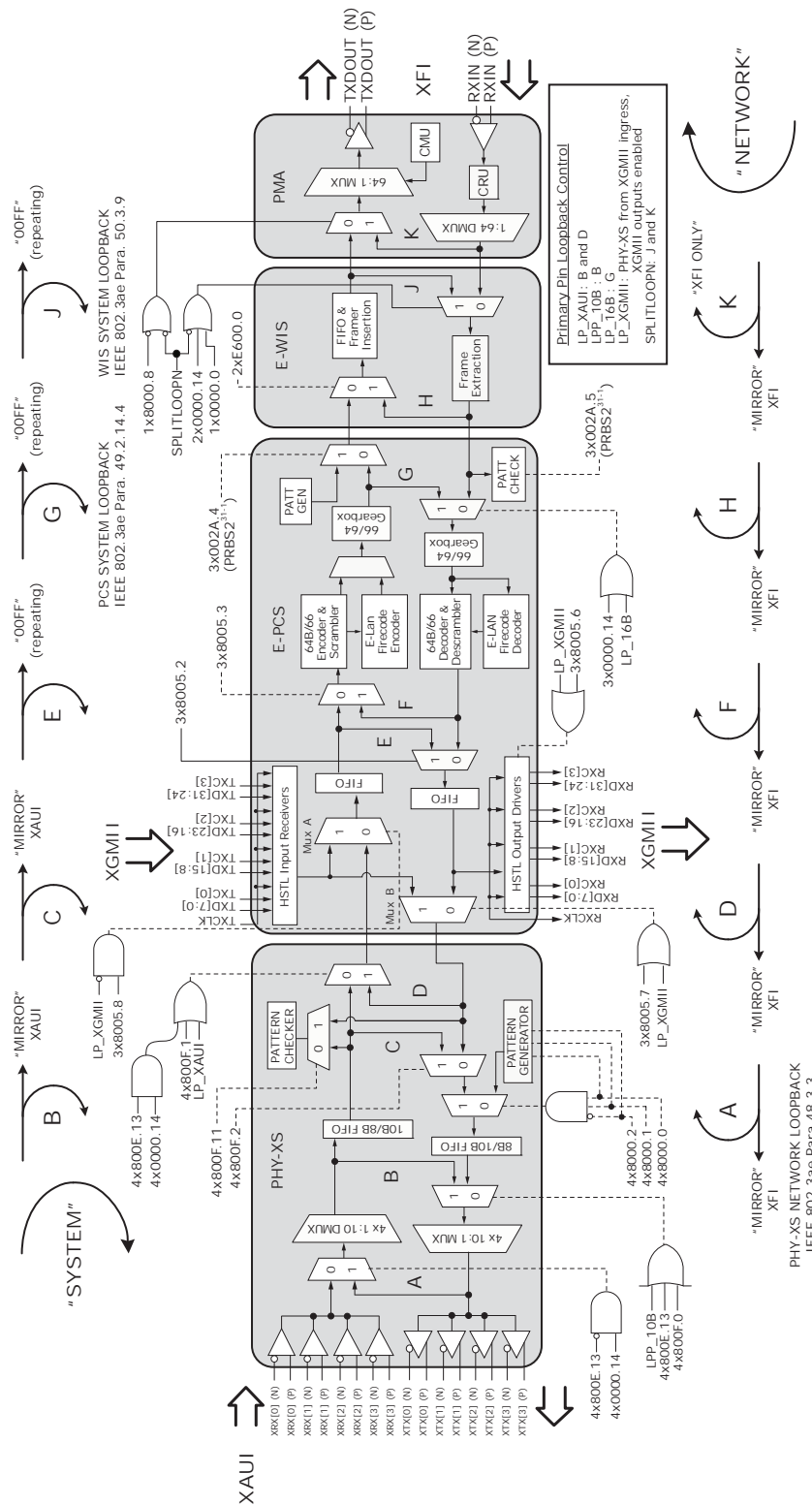
## 3.2 Loopback

The VSC8486-04 LAN PHY has three 10-gigabit data ports: XAUI, XFI, and XGMII. There are several options available to the user for routing traffic between the various ports. The purpose of this section is to outline the operation of several modes loosely termed loopbacks. These modes can be extremely useful for both test and debug purposes.

In addition to loopbacks, the device contains several pins that configure the device for XGMII or XAUI operation without requiring MDIO access.

Loopback paths are shown in the following illustration.

Figure 4 • Loopback Configuration



Two split loopback paths (that is, two loopback paths simultaneously switched on) are enabled by the SPLITLOOPN and LP\_XAUI pins. Most other data path routing and loopback controls are enabled through the MDIO interface.

### 3.2.1 Input/Output Mode Select and XGMII Mode

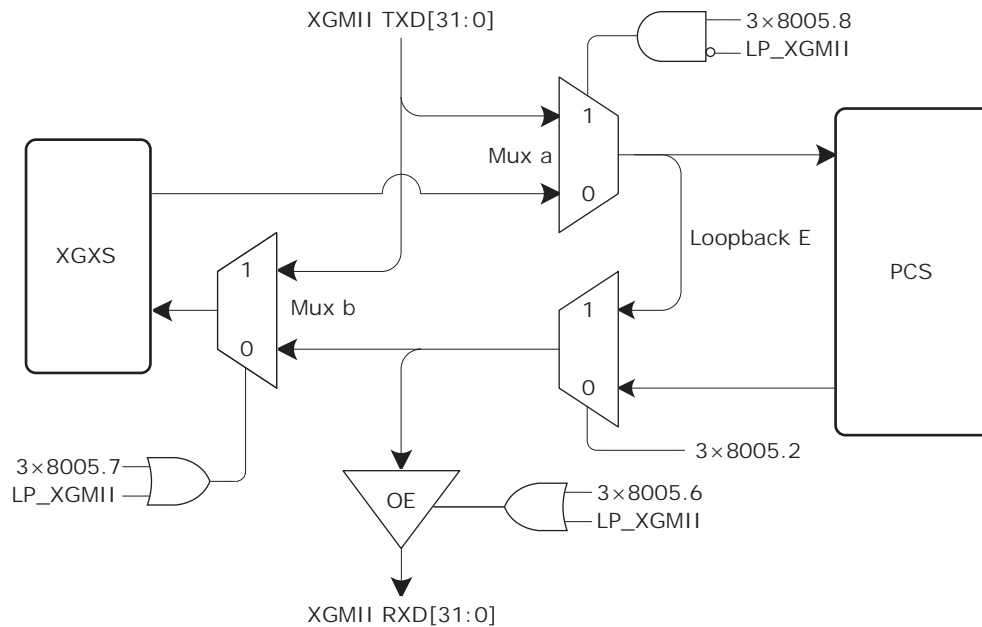
On power up or reset, the state of the IOMODESEL pin sets the VSC8486-04 data path routing on chip as follows:

1. On reset, if IOMODESEL = 0, then 3×8005.8:6 is set to 101. This setting programs multiplexers a and b for XGMII mode and enables the XGMII output drivers.
2. On reset, if IOMODESEL = 1, 3×8005.8:6 is set to 000. This setting programs multiplexers a and b for XAUI mode and disables the XGMII output.

Mux a, mux b, and OE controls can also be configured after a reset, using the MDIO 3×8005.8:6 bits.

If LP\_XGMII is pulled high, the XGMII output is enabled and the XGXS receives its data from the XGMII input, TXD[31:0], regardless of the settings for IOMODESEL or the 3×8005.8:6 bits. The VSC8486-04 can be programmed to mirror XGMII Tx input data simultaneously to the PCS and the XGXS. Alternatively, the PCS data can be routed simultaneously to the XGMII Rx output and the XGXS.

**Figure 5 • Data Path XGMII Source**



The following table summarizes the control settings using the IOMODESEL pin.

**Table 1 • Pin Control for XGMII After Reset**

IOMODESEL Pin Control	XGMII Data Source		XGMII Output Driver Enabled?	3×8005 Register Value Set on Reset		
	XGXS	PCS		Bit 8	Bit 7	Bit 6
0		XGMII TXD[31:0]	Yes	1	0	1
1	PCS	XGXS	No	0	0	0

The following table summarizes control settings using the MDIO registers, where XGMII output is always from PCS.

**Table 2 • MDIO Control for XGMII**

3x8005 MDIO						
Register Settings			Data Source		XGMII Output	Description
Bit 8	Bit 7	Bit 6	PCS	XGXS		
0	0	0	XGXS	PCS	Off	XGXS data comes from PCS, PCS data comes from XGXS. XGMII output drivers disabled.
0	0	1	XGXS	PCS	On	XGXS data comes from PCS, PCS data comes from XGXS. XGMII RXD comes from PCS. (Mirror PCS data to XGMII.)
0	1	0	XGXS	XGMII TXD	Off	XGXS data comes from XGMII TXD, PCS data comes from XGXS. XGMII output drivers disabled.
0	1	1	XGXS	XGMII TXD	On	XGXS data comes from XGMII TXD, PCS data comes from XGXS. XGMII RXD comes from PCS.
1	0	0	XGMII TXD	PCS	Off	XGXS data comes from PCS, PCS data comes from XGMII TXD. XGMII output drivers disabled.
1	0	1	XGMII TXD	PCS	On	XGXS data comes from PCS, PCS data comes from XGMII TXD. XGMII RXD comes from PCS. (Mirror PCS data to XGMII.)
1	1	0	XGMII TXD	XGMII TXD	Off	XGXS data comes from XGMII TXD, PCS data comes from XGMII TXD. XGMII output drivers disabled. (Mirror XGMII TXD to XGXS.)
1	1	1	XGMII TXD	XGMII TXD	On	XGXS data comes from XGMII TXD, PCS data comes from XGMII TXD. XGMII RXD comes from PCS. (Mirror XGMII TXD to XGXS.)

### 3.2.2 Loopback Modes

There are three types of loopback modes: system, network, and split loopbacks. In general, system loopbacks affect XAUI traffic, network loopbacks affect XFI traffic, and split loopbacks affect both. The following table provides a summary of the system loopbacks.

**Table 3 • System Loopback Summary**

Loopback	Name	Loopback Enable	Retiming
B	PHY XS shallow system loopback	Any of the following: LPP_10B = 1 LP_XAUI = 1 4x800E.13 = 1 4x800F.0 = 0	Phase delay only, XAUI TX[3:0] signals retimed from XAUI XRX[3:0] recovered clock
C	PHY XS deep system loopback	4x800F.2 = 1	XAUI TX[3:0] signals retimed to LAN clock (REFCLKP/N)



**Table 3 • System Loopback Summary (continued)**

Loopback	Name	Loopback Enable	Retiming
E	PCS FIFO system loopback	3×8005.2 = 1	XAUI XTX[3:0] signals retimed to LAN clock (REFCLKP/N)
G	PCS system loopback	LP_16B = 1 or 3×0000.14 = 1	XAUI XTX[3:0] signals retimed to LAN clock (REFCLKP/N)
J	PMA/WIS system loopback	Any of the following: SPLITLOOPN = 0 (active low) 2×0000.14 = 1 1×0000.0 = 1	XAUI XTX[3:0] signals retimed to LAN clock (REFCLKP/N)

For system loopbacks, the XAUI data can be mirrored to the XFI Tx port, depending on the register setting of XFI\_LPBK\_OVR (1×EF10.2).

**Table 4 • System Loopback and XFI Traffic**

Loopback	If XFI_LPBK_OVR (1×EF10.2) = 0 <sup>1</sup>	If XFI_LPBK_OVR (1×EF10.2) = 1
B	XFI Tx traffic from WIS/PCS	XFI Tx traffic set by 1×EF10.1:0 00: 0×00FF pattern 01: All zeros 10: All ones 11: WIS/PCS
C	XFI Tx traffic from WIS/PCS	XFI Tx traffic set by 1×EF10.1:0 00: 0×00FF pattern 01: All zeros 10: All ones 11: WIS/PCS
E, G, or J	0×00FF pattern	XFI Tx traffic set by 1×EF10.1:0 00: 0×00FF pattern 01: All zeros 10: All ones 11: WIS/PCS

1. The XFI\_LPBK\_OVR (1×EF10.2) register defaults to 0.

The following table provides a summary of the network loopbacks, which primarily affect XFI traffic.

**Table 5 • Network Loopbacks Summary**

Loopback	Name	Loopback Enable	Retiming
A	PHY XS deep network loopback	4×0000.14 = 1 and 4×800E.13 = 0	See <a href="#">Table 7</a> , page 13
D	PHY XS shallow network loopback	Any of the following: 4×800E.13 = 0 and 4×0000.14 = 0 4×800F.1 = 1 LP_XAUI = 1	See <a href="#">Table 7</a> , page 13
F	PCS gearbox network loopback	3×8005.3 = 1	See <a href="#">Table 7</a> , page 13
H	WIS network loopback	2×E600.0 = 1	See <a href="#">Table 7</a> , page 13

**Table 5 • Network Loopbacks Summary (continued)**

Loopback	Name	Loopback Enable	Retiming
K	PMA network loopback	Any of the following: SPLITLOOPN = 0 (active low) 1×8000.8 = 0	See Table 7, page 13

Split loopback affects both XAUI and XFI traffic. Split loopback is enabled using the LP\_XAUI and SPLITLOOPN pins, as shown in the following table.

**Table 6 • Split Loopbacks Summary**

Loopback	Name	Loopback Enable	Retiming
B and D	XAUI split loopback	LP_XAUI = 1 Internally pulled low	See Table 7, page 13
J and K	PMA split loopback	SPLITLOOPN = 0 Internally pulled high	See Table 7, page 13

### 3.2.2.1 Retiming Clock Sources for Network and Split Loopbacks

For network and split loopbacks, there are various options for controlling the XFI retiming, as shown in the following table. For retiming XAUI traffic (pins XTX[3:0]), REFCLKP/N is used; however, when the split loopback B and D is active, the recovered clock from XRX[3:0] is used.

**Table 7 • Retiming Clock Sources for Network and Split Loopbacks**

WAN_STAT (1×E606.15)	LINETIME_STAT (1×E606.13)	XFI Retimed With
0	0	REFCLKP/N
0	1	10G LINE_IN
1	0	WREFCLKP/N
1	1	10G LINE_IN

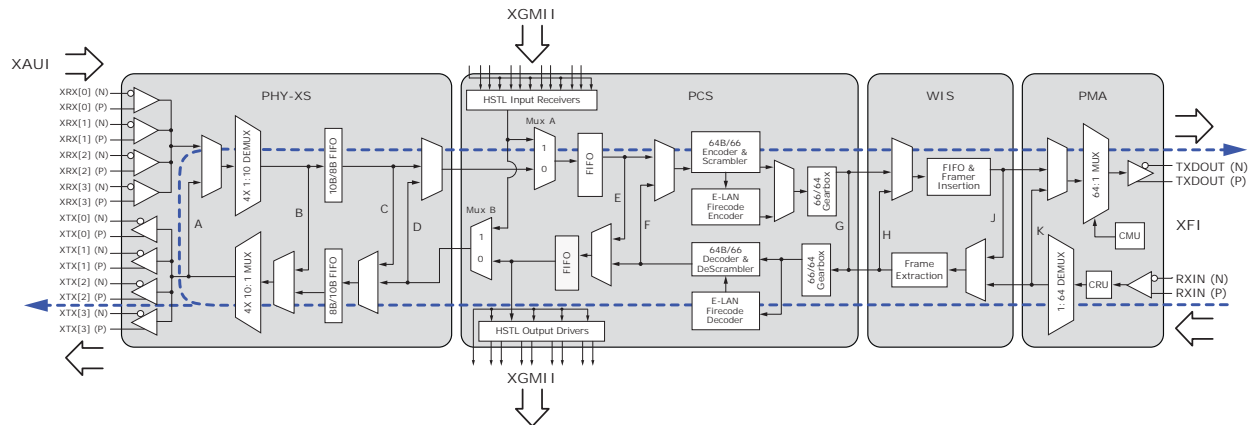
## 3.3 Loopback Paths

This section describes each loopback, listed in alphabetical order.

### 3.3.1 Loopback A

Loopback A is located in the XAUI PHY. It reroutes the data from the 10:1 MUX in the XAUI PHY into the 1:10 DEMUX, as shown in the following illustration.

**Figure 6 • PHY XS Deep Network Loopback**



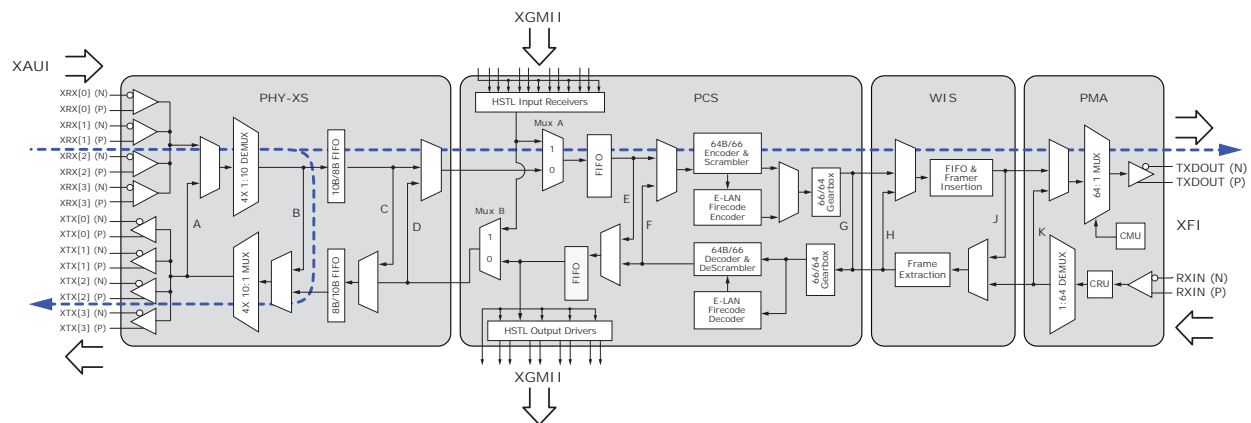
XFI data is retimed with PMA CRU. To enable loopback A, set both of the following: LPBK\_A (4x0000.14) set to 1 and LPBK\_B (4x800E.13) set to 0. The default value for bit 14 is 0 (loopback disabled). XFI ingress (RXINP/N) data is mirrored to the XAUI egress port (XTX[3:0]P/N) simultaneously without further MDIO instructions. This loopback cannot be used if LP\_XAUI is asserted high.

**Note:** For loopback A to function without a XAUI input present, the XS Rx signal detect register 4xE600.1 must be set to 1 in order for the XAUI inputs to sync up.

### 3.3.2 Loopback B

Loopback B routes the incoming XAUI data through the 1:10 DEMUX and then loops back before the 10b/8b decoder into the 10:1 MUX. Data is retimed by the recovered XAUI clock. No 10b/8b decoding or lane synchronization is performed. System XAUI data is also mirrored to the XFI Tx port. To enable loopback B, set the LPBK\_B register (4x800E.13) to 1, the LPP\_10B pin to high, or the LP\_XAUI pin to high. The LP\_XAUI pin setting simultaneously enables loopback D.

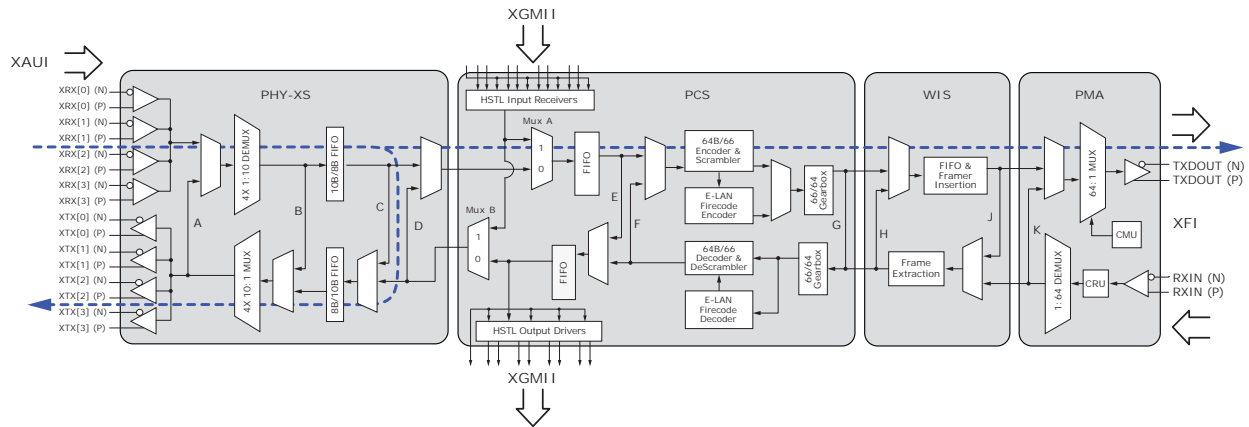
**Figure 7 • PHY XS Shallow System Loopback**



### 3.3.3 Loopback C

Loopback C routes the incoming XAUI data after the 10b/8b FIFO back into the 8b/10b FIFO. System XAUI data is also mirrored to the XFI Tx port. To enable loopback C, set LPBK\_C (4x800F.2) to 1.

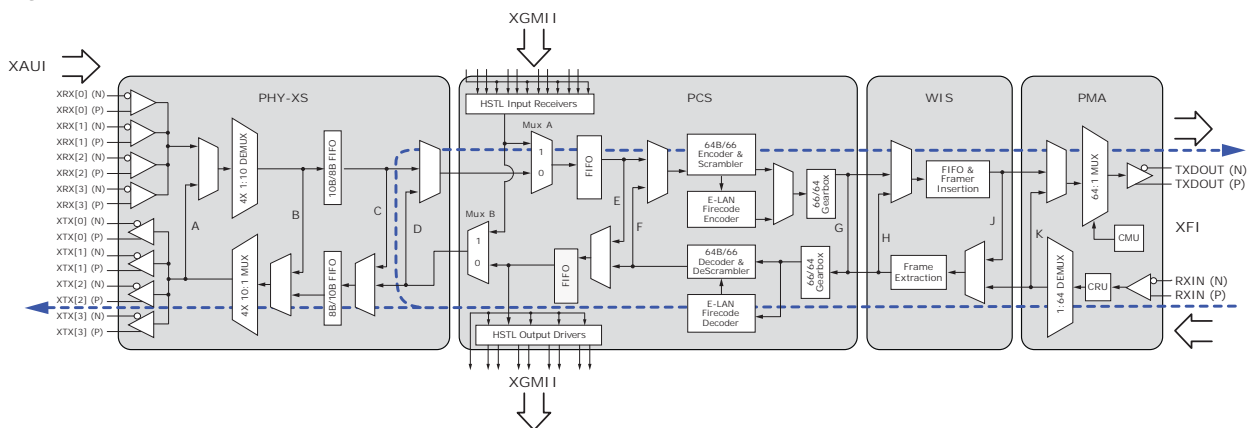
**Figure 8 • PHY XS Deep System Loopback**



### 3.3.4 Loopback D

Loopback D routes the incoming XFI data after the PCS FIFO back into the transmit PCS FIFO. Network XFI Rx data is also mirrored to the XAUI egress port. To enable loopback D, set either the LPBK\_D register (4x800F.1) to 1, both the LPBK\_B (4x800E.13) and LPBK\_A (4x0000.14) registers to 1, or the LP\_XAUI pin to high. The LP\_XAUI pin setting simultaneously enables loopback B.

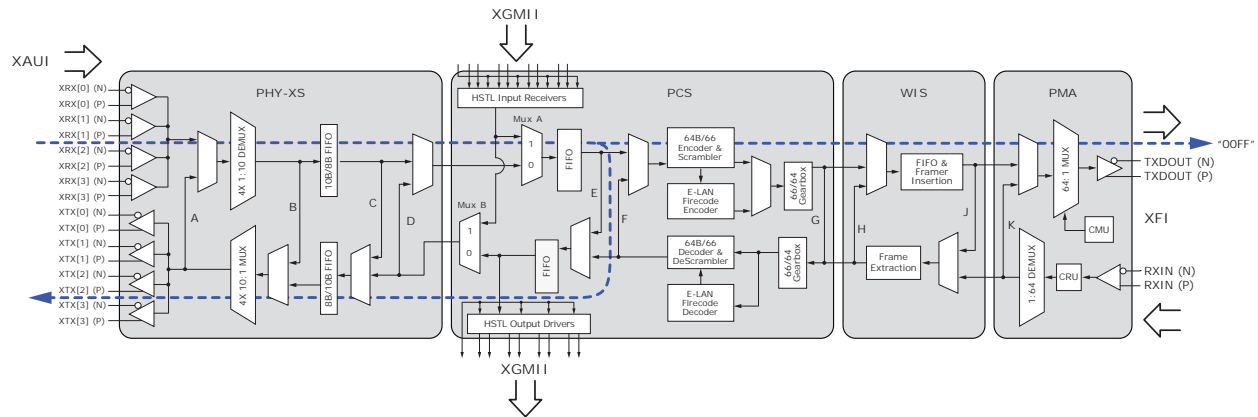
**Figure 9 • PHY XS Shallow Network Loopback**



### 3.3.5 Loopback E

Loopback E routes the incoming XAUI data from the PCS transmit FIFO back into the PCS receive FIFO. The data transmitted to the XFI Tx port is a continuous stream of 0x00FF data words. To enable loopback E, set LPBK\_E (3x8005.2) to 1.

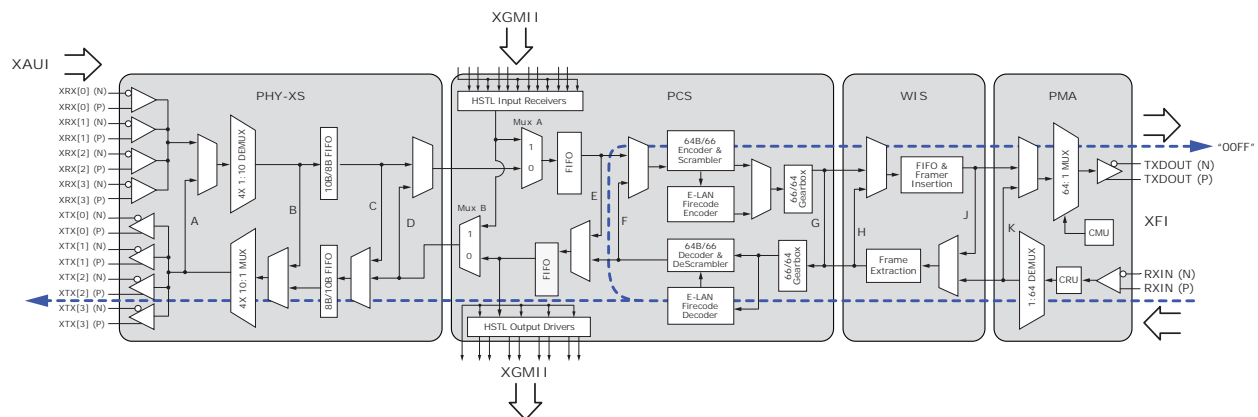
**Figure 10 • PCS FIFO System Loopback**



### 3.3.6 Loopback F

Loopback F routes the incoming XFI data after the receive PCS gearbox back into the transmit PCS gearbox. Network XFI Rx data is also mirrored to the XAUI egress port. To enable loopback F, set LPBK\_F (3×8005.3) to 1.

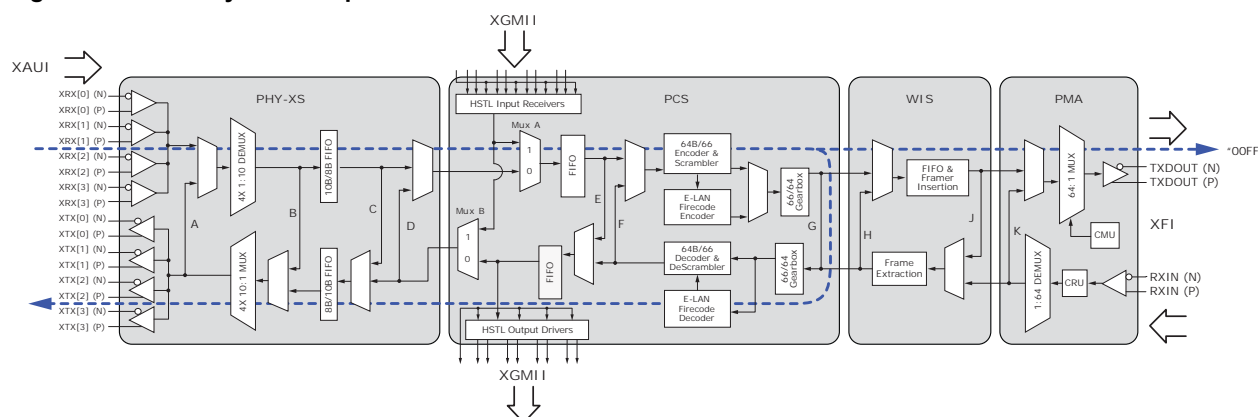
**Figure 11 • Gearbox Network Loopback**



### 3.3.7 Loopback G

Loopback G routes the incoming XAUI data through the PCS transmit gearbox back into the PCS receive gearbox. The data transmitted to the XFI Tx port is a continuous stream of 0×00FF data words. To enable loopback G, either set LPBK\_G (3×0000.14) to 1 or set the LP\_16B pin high.

**Figure 12 • PCS System Loopback G**

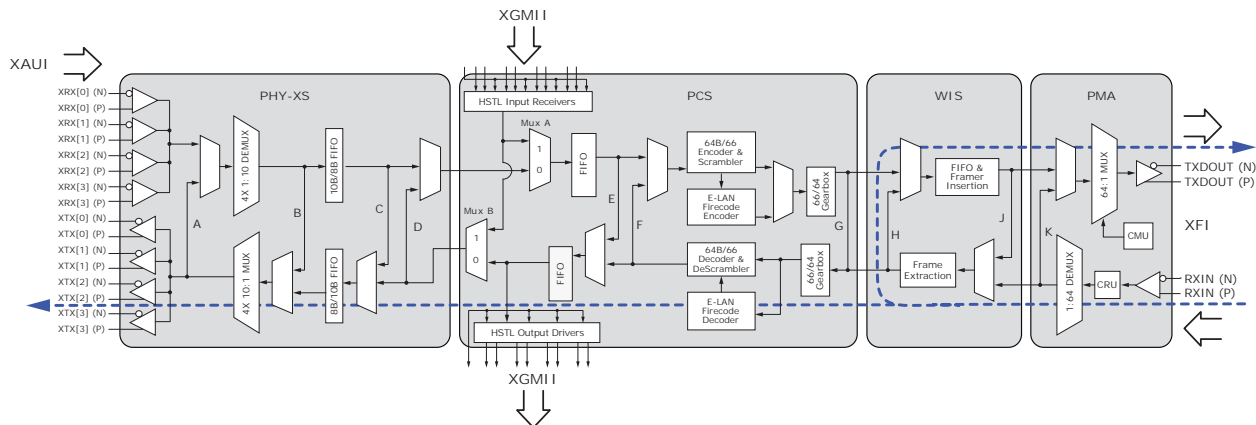


### 3.3.8 Loopback H

Loopback H routes the incoming XFI data from the PMA or WIS received data back into the PMA or WIS transmit path. Network XFI Rx data is also mirrored to the XAUI egress port. To enable loopback H, set LPBK\_H (2×E600.0) to 1.

**Note:** Loopback H is intended for WAN mode only, and is not designed to work in LAN mode. For proper function of Loopback H in path generation/termination, the VSC8486-04 device must not receive frames in which the payload pointer is incremented or decremented. The Tx SONET frame for the VSC8486-04 should always have the payload pointer in a fixed location (522), otherwise the Tx and Rx paths will not be frequency-locked. When the Tx and Rx paths are not frequency-locked, the Rx WIS can receive a different number of bytes than the Tx WIS sends out, resulting in an overflow/underflow condition.

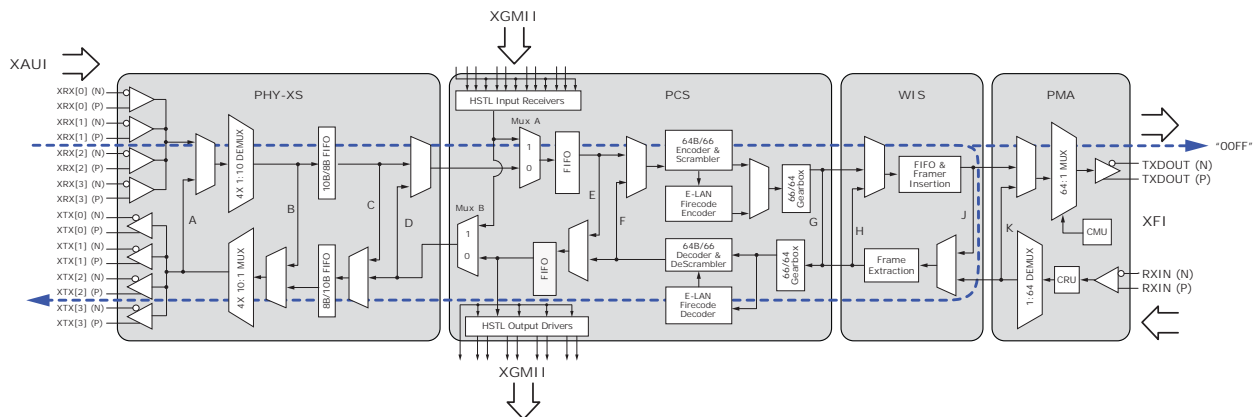
Figure 13 • PCS System Loopback H



### 3.3.9 Loopback J

Loopback J routes the incoming XAUI data from the PCS (or WIS if enabled) back into the PCS (or WIS if enabled). This loopback is enabled for both PMA and WIS system loopbacks. The data transmitted to the XFI Tx port is a continuous stream of 0×00FF data words. To enable loopback J, set any of the following: LPBK\_J\_PMA (1×0000.0) set to 1 or LPBK\_J\_WIS (2×0000.14) set to 1 or the SPLITLOOPN pin set low. Setting the SPLITLOOPN pin low also enables loopback K.

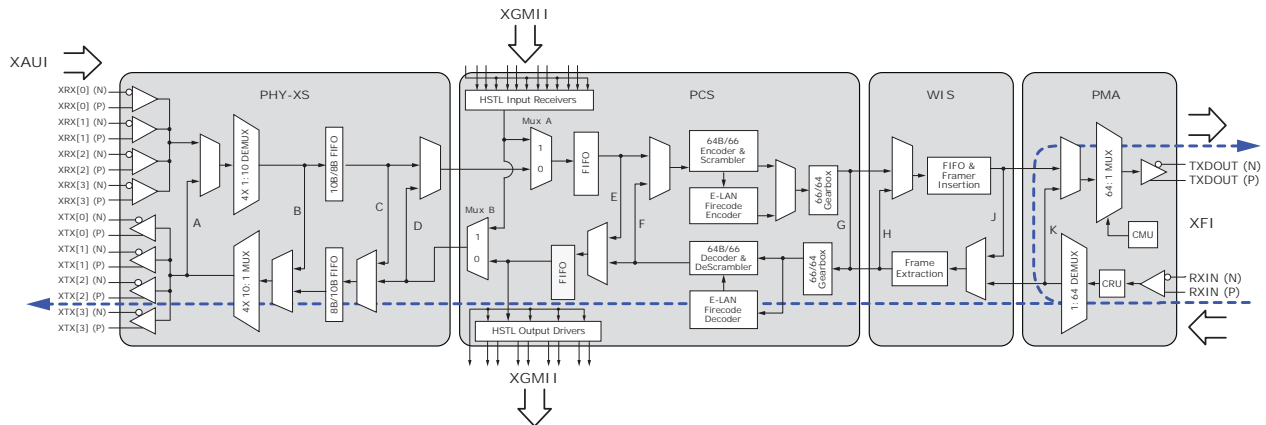
Figure 14 • PMA/WIS System Loopback



### 3.3.10 Loopback K

Loopback K routes the incoming 10-gigabit XFI data back to the 10-gigabit XFI output, as shown in the following illustration.

**Figure 15 • PMA Network Loopback**

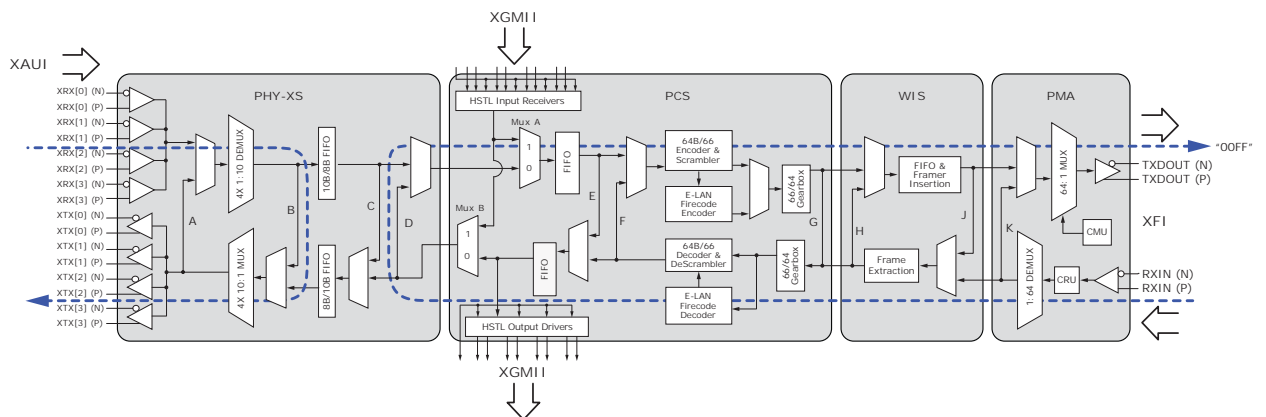


Loopback K is protocol agnostic. Data is retimed with the 10-gigabit recovered clock. Network XFI Rx data is also mirrored to the XAUI egress port. To enable loopback K, set any of the following: LPBKN\_K (1×8000.8) set to 0 (the default is 1, disabled) or set the SPLITLOOPN pin low. Setting the SPLITLOOPN pin low also enables loopback J.

### 3.3.11 XAUI Split Loopbacks B and D

Split loopback paths B and D are simultaneously enabled by setting LP\_XAUI high. Loopback D XFI output data is retimed by the local LAN or WAN refclk. If left unconnected, the LP\_XAUI input is pulled down on-chip, disabling these loopback paths.

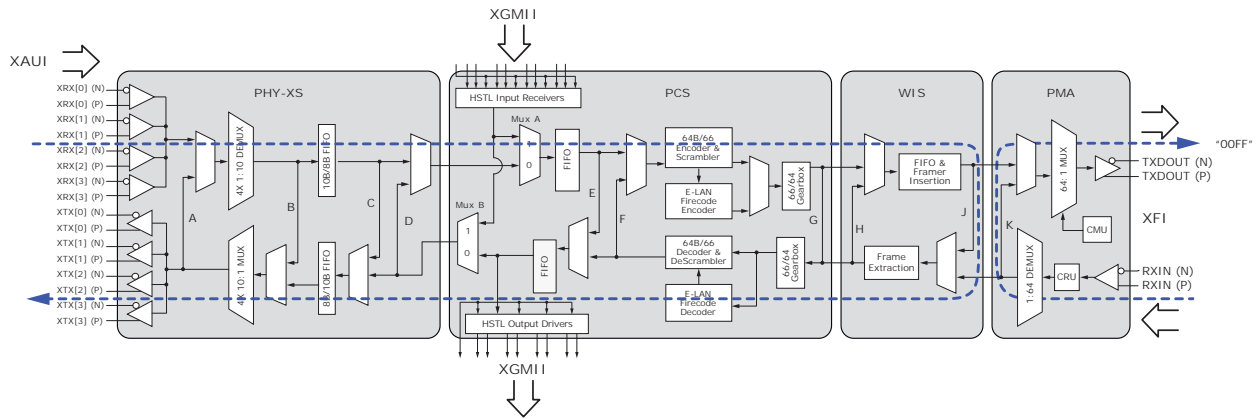
**Figure 16 • XAUI Split Loopback**



### 3.3.12 PMA Split Loopbacks J and K

Split loopback paths J and K are simultaneously enabled by setting SPLITLOOPN low. Loopback J recovers the clock from the XAUI ingress data, passes through a rate compensation FIFO, and is timed out by the LAN REFCK. Loopback K is retimed by the 10-gigabit recovered clock. If left unconnected, the SPLITLOOPN input is pulled up on chip, disabling these loopback paths.

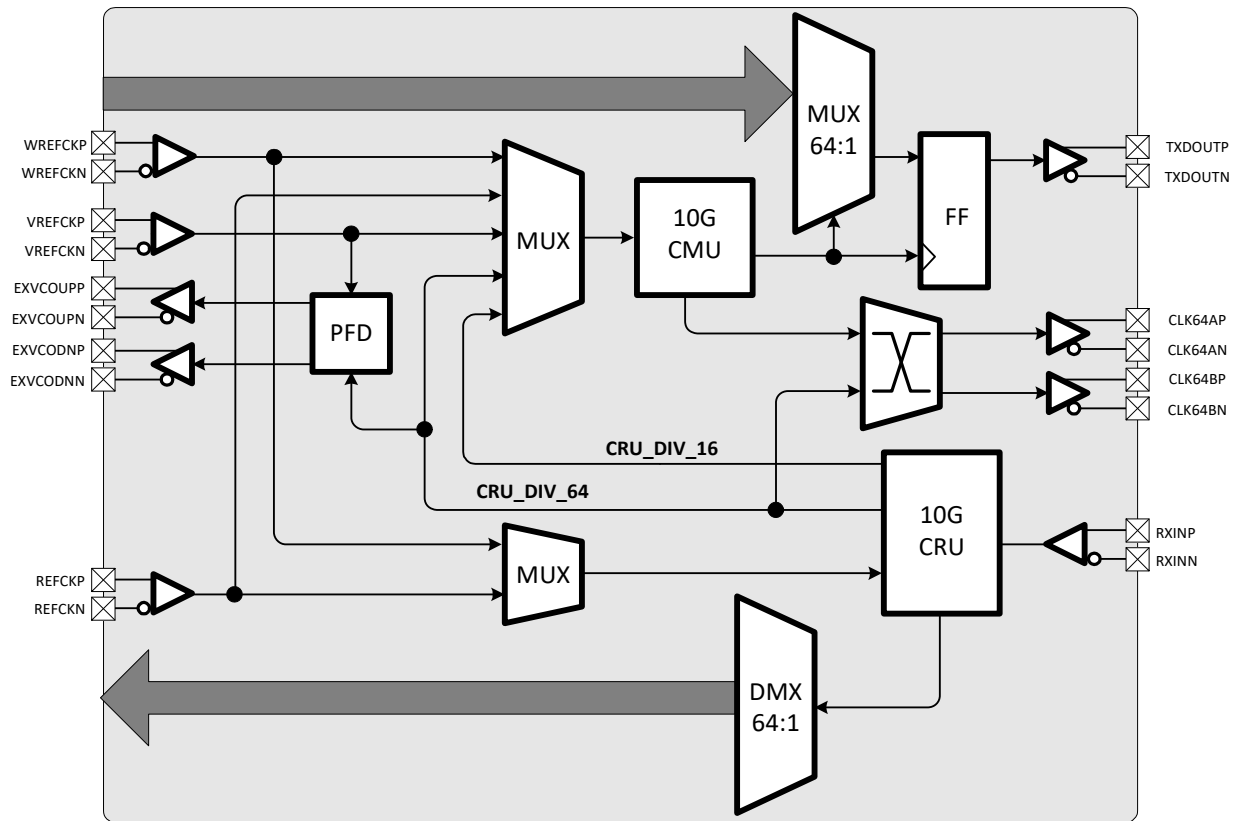
**Figure 17 • PMA Split Loopback**



### 3.4 Physical Media Attachment

The following block diagram shows the physical media attachment (PMA).

**Figure 18 • PMA Block Diagram**



#### 3.4.1 Multiplexer Operation

The PMA transmitter includes a CMU and a 64-bit multiplexer that receives 64-bit data from the PCS (or WIS) block, which generates the high-speed serial output on pins TXDOUTP/N. The output speeds are 10.3125 Gbps in LAN mode, 10.51875 Gbps in SAN mode, or 9.95328 Gbps in WAN mode.

The CMU provides a divide-by-64 clock output on pins CLK64AP/N or CLK64BP/N for optional use as a reference clock to an XFP module or external phase lock loop circuit. The clock output speeds are 161.133 MHz in LAN mode, 164.355 MHz in SAN mode, or 155.52 MHz in WAN mode.



By default, TX\_MSBSEL (1×8000.6) is set to 1, resulting in the PMA transmitting the least significant bit (LSB) first. Using MDIO, the most significant bit (MSB) can be selected as the first bit transmitted.

The high-speed output data (TXDOUTP/N) can be muted (that is, set to continuous zeros) by setting the TXONOFF1 pin low. If left unconnected, the default for TXONOFF1 is 1, which is set by an on-chip pull-up.

### 3.4.2 Timing Operation

The VSC8486-04 supports two types of timing operation, normal and linetime. During normal timing, with LINETIME\_STAT (1×E606.13) = 0, the device transmits data synchronous to the REFCLKP/N or WREFCLKP/N input if in WAN mode (1×E606.14). In Linetime mode (LINETIME\_STAT = 1), the device transmits data synchronous to the receiver's recovered clock. The VSC8486-04 provides the necessary divided-down clock outputs and internal phase detector to enable users to synthesize an external phase lock loop jitter attenuation circuit. A voltage controlled SAW oscillator (VCSO) is recommended for optimum phase noise and jitter performance. The VCSO frequency must be 622.08 MHz and connected to the VREFCLKP/N pins.

The default state for the LINETIME\_FRC bit (1×E605.4) is 0 (linetime disabled). To enable linetiming, set this bit to 1. The linetime status bit (1×E606.13) shows the linetime status.

### 3.4.3 Reference Clock Rate Selection

The VSC8486-04 supports two WAN mode reference clock rate options. By default, REFSEL0 controls the REFSEL0\_STAT state. The pin control has various overrides, as listed in the following table (X indicates "doesn't matter").

**Table 8 • REFSEL0\_STATUS Logic**

Inputs			Result	
REFSEL0	REFSEL0_OVR (1×E605.7)	REFSEL0_FORCE (1×E605.6)	WREFCLK Frequency	REFSEL0_PIN_STATUS (1×E606.12)
Low (default)	0 (default)	X	622.08 MHz	0
High	0	X	155.52 MHz	1
X	1	0	622.08 MHz	X
X	1	1	155.52 MHz	X

### 3.4.4 WAN Mode

By default, the WAN\_MODE controls the WAN\_STAT state. The pin control has various overrides, as listed in the following table (where X indicates "doesn't matter").

**Note:** When written, registers 2×0007 and 3×0007 provide a microcontroller interrupt.

**Table 9 • WAN Mode Control Logic**

Inputs					Result	
WAN_MODE	PCS Type Selection (2×0007.0)	PCS Mode (3×0007.1:0)	WAN_OVR (1×E605.3)	WAN_FORCE (1×E605.2)	WAN_STAT (1×E606.15)	WAN_MODE_ PSTAT (1×E606.14)
Low	0	00	0	X	0	0
High	X	X	0	X	1	1
X	X	X	1	0	0	X
X	X	X	1	1	1	X
X	1	X	0	X	1	X
X	X	10	0	X	1	X

### 3.4.5 Clock Multiplier Unit Reference Clacking

For LAN and SAN applications (WAN\_STAT = 0), an on-chip PLL generates the high-speed transmit clock from the externally provided REFCLKP/N input during normal timing operation or from the recovered high-speed receive clock during linetiming operation. The REFCLKP/N input must be one sixty-sixth of the serial data rate (156.25 MHz for LAN mode or 159.375 MHz for SAN mode). The XAUI transmitter and receiver also use the REFCLKP/N input.

For WAN applications (WAN\_STAT = 1), an additional reference clock is required for the high-speed data (9.95328 Gbps). The on-chip PLL generates the high-speed transmit clock from one of three sources: the externally provided WREFCLKP/N input, the recovered high speed receive clock, or from an external VCISO as part of a jitter attenuation PLL circuit that enters the device at VREFCLKP/N. In both normal timing operation and in linetiming operation, the WREFCLKP/N reference clock must be present and can be either 155.52 MHz (REFSEL0 = 1) or 622.08 MHz (REFSEL0 = 0, which is the default). In linetiming operation (LINETIME\_STAT = 1), the transmit clock is generated from the 10-gigabit CRU. As with LAN and SAN modes, the XAUI clock is generated from the REFCLKP/N input.

The on-chip PLL uses a low phase noise reactance-based VCO. The reference clock should be of high quality because noise on the reference clock below the PLL loop bandwidth passes through the PLL and appears as jitter on the outputs (TXDOUTP/N and CLK64AP/N). During such conditions, the VSC8486-04 transfers reference clock noise in addition to its own intrinsic jitter. Preconditioning the reference clock signal might be necessary to avoid passing reference clock noise.

The following table summarizes these reference clock controls and the associated frequencies. The transmit and receive references are also provided.

**Table 10 • CMU and CRU Reference Clock Control and Frequency Summary**

Mode Description	LINE TIME_S TAT	WAN_S TAT	REFSEL0 _STATUS	REFCLKP, REFCLKN, (MHz)	WREFCLKP, WREFCLKN (MHz)	Transmit Reference (10G CMU)	Receive Reference (10G CRU)
1: LAN/SAN mode, normal timing	0	0	X	156.25 or 159.375	NC	REFCLKP, REFCLKN	REFCLKP, REFCLKN
2: WAN mode, normal timing	0	1	0	156.25	622.08	WREFCLKP, WREFCLKN	WREFCLKP, WREFCLKN divided by 4
3: WAN mode, 155.52 MHz reference clock normal timing	0	1	1	156.25	155.52	WREFCLKP, WREFCLKN	WREFCLKP, WREFCLKN
4: LAN/SAN mode, linetiming	1	0	0	156.25 or 159.375	NC	CRU recovered clock divided by 64	REFCLKP, REFCLKN
5: LAN/SAN mode, linetiming	1	0	1	156.25 or 159.375	NC	CRU recovered clock divided by 16	REFCLKP, REFCLKN
6: WAN mode, linetiming with external jitter attenuation circuit	1	1	0	156.25	622.08	VREFCLKP, VREFCLKN (only at 622.08 MHz)	WREFCLKP, WREFCLKN divided by 4
7: WAN mode, linetiming with 155.52 reference clock	1	1	1	156.25	155.52	CRU recovered clock divided by 16	WREFCLKP, WREFCLKN

### 3.4.6 Reference Clock Inputs

The VSC8486-04 determines the PMA timing mode by decoding the inputs for LINETIME\_STAT, WAN\_STAT, and REFSEL0\_STATUS. The following tables define the logic for these three inputs and the available modes. VSC8486-04 always requires a 156.25 MHz (159.375 MHz) reference clock applied to REFCLKP/N for all operating modes.

#### 3.4.6.1 LAN/SAN Only

For applications supporting LAN/SAN only, we recommend the configuration depicted in the following table. WAN mode is not supported by this configuration. The input signals for this configuration are:

- REFCLKP/N = 156.25 MHz or 159.375 MHz
- WREFCLKP/N = none
- VREFCLKP/N = none

In the following tables, X indicates “doesn’t matter.”

**Table 11 • LAN/SAN Configuration**

LINETIME_STAT	WAN_S_TAT	REFSEL0_STATUS	Transmit Reference (10G CMU)	Receive Reference (10G CRU)	Mode Description
0	0	X	REFCLKP/N	REFCLKP/N	Normal timing, LAN/SAN mode
1	0	0	CRU divided by 64	REFCLKP/N	Linetime, LAN, or SAN mode
1	0	1	CRU divided by 16	REFCLKP/N	Linetime, LAN, or SAN mode

#### 3.4.6.2 LAN/SAN/WAN With SONET/SDH Jitter Generation Compliance

For applications that require SONET/SDH jitter performance but do not require clock cleanup, we recommend the configuration depicted in the following table. In this configuration, the 622.08 MHz clock provides the best jitter generation performance. This configuration does not support clock cleanup in linetime mode. The input signals for this configuration are:

- REFCLKP/N = 156.25 MHz or 159.375 MHz
- WREFCLKP/N = 622.08 MHz
- VREFCLKP/N = none

**Table 12 • SONET/SDH Jitter Generation-Compliant Configuration**

LINETIME_STAT	WAN_S_TAT	REFSEL0_STATUS	Transmit Reference (10G CMU)	Receive Reference (10G CRU)	Mode Description
0	0	X	REFCLKP/N	REFCLKP/N	Normal timing, LAN/SAN mode
0	1	0	WREFCLKP/N	WREFCLKP/N	Normal timing, WAN mode
1	0	0	CRU divided by 64	REFCLKP/N	Line timing, LAN/SAN mode
1	0	1	CRU divided by 16	REFCLKP/N	Line timing, LAN/SAN mode

#### 3.4.6.3 LAN/SAN/WAN Without SONET/SDH Jitter Generation Compliance

For applications that do not need to meet SONET/SDH jitter requirements and do not need to use the recovered clock, we recommend the configuration depicted in the following table. In this configuration,

the 155.52 MHz clock does not provide the best jitter generation performance. This configuration does not support clock cleanup in lincetime mode. The input signals for this configuration are:

- REFCLKP/N = 156.25 MHz or 159.375 MHz
- WREFCLKP/N = 155.52 MHz
- VREFCLKP/N = none

In the following table, X indicates “doesn’t matter.”

**Table 13 • Non-SONET/SDH Jitter Generation-Compliant Configuration**

LINETIME_ STAT	WAN_S TAT	REFSELO_ STATUS	Transmit Reference (10G CMU)	Receive Reference (10G CRU)	Mode Description
0	0	X	REFCLKP/N	REFCLKP/N	Normal timing, LAN/SAN mode
0	1	1	WREFCLKP/N	WREFCLKP/N	Normal timing, WAN mode
1	0	0	CRU divided by 64	REFCLKP/N	Line timing, LAN/SAN mode
1	0	1	CRU divided by 16	REFCLKP/N	Line timing, LAN/SAN mode
1	1	1	CRU divided by 16	WREFCLKP/N	Line timing, WAN mode

### 3.4.6.4 LAN/SAN/WAN With Full SONET/SDH Jitter Compliance

For applications that require full SONET/SDH quality jitter in normal and lincetime modes, we recommend the configuration depicted in the following table. The input signals for this configuration are:

- REFCLKP/N = 156.25 MHz or 159.375 MHz
- WREFCLKP/N = 622.08 MHz
- VREFCLKP/N = 622.08 MHz

**Table 14 • SONET/SDH Jitter-Compliant Configuration**

LINETIME_ STAT	WAN_S TAT	REFSELO_ STATUS	Transmit Reference (10G CMU)	Receive Reference (10G CRU)	Mode Description
0	0	X	REFCLKP/N	REFCLKP/N	Normal timing, LAN mode
0	1	0	WREFCLKP/N	WREFCLKP/N	Normal timing, WAN mode
1	0	0	CRU/64	REFCLKP/N	Normal timing, LAN mode
1	0	1	CRU/16	REFCLKP/N	Normal timing, LAN mode
1	1	0	VREFCLKP/N	WREFCLKP/N	Line timing WAN mode

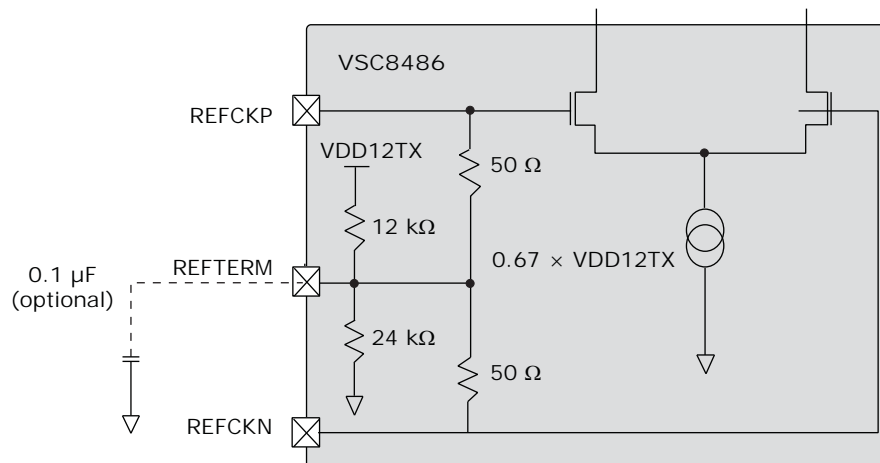
The incoming low-speed reference clock (REFCLKP/N) is received by a differential LVPECL buffer as shown in [Figure 19](#), page 24.

The on-chip termination is 100 Ω equivalent between true and complement. An internal bias generator, nominally set at  $0.67 \times VDD12TX$ , is provided for AC-coupling. An internal termination tap, REFTERM, is provided to allow adjustment of the input common-mode voltage. It is recommended to add an external capacitor between REFTERM, and VDD or ground. Single-ended reference clock operation is possible,

and when implemented, both inputs must have equivalent termination. However, the best jitter performance is obtained using a low phase noise, differential reference clock.

When interfacing with 3.3 V LVPECL clock sources, always use AC coupling capacitors in series with true and complement reference clock inputs on the VSC8486-04. The recommended ceramic capacitor value is 0.1  $\mu\text{F}$ , size 0402.

**Figure 19 • Reference Clock Input Receiver**

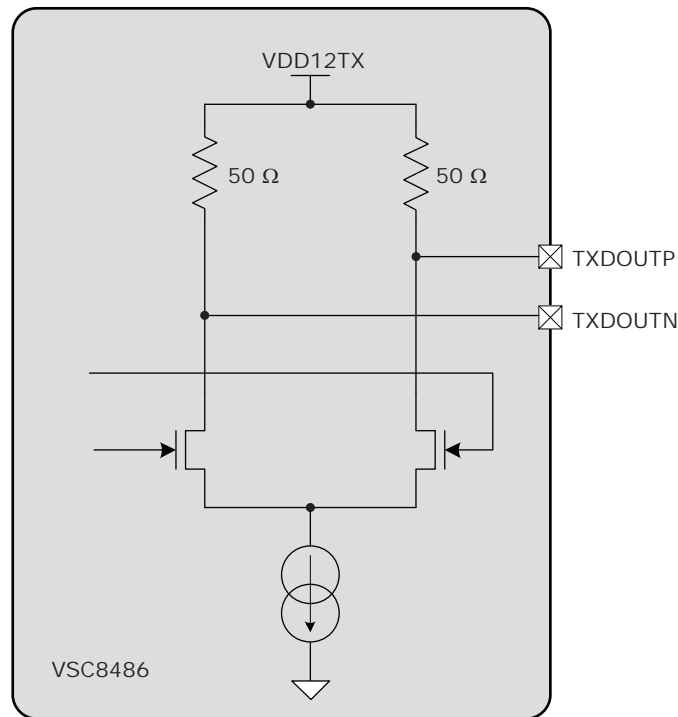


### 3.4.7 External Capacitors

For loop filter control and for minimizing the impact of power supply noise and other common-mode noise, the on-chip PLLs require 1.0  $\mu\text{F}$  external capacitors. The external capacitors must be connected between pins CMUFILT and ground for the CMU, and between CRUFILT and ground for the CRU. These capacitors should be a multilayer ceramic dielectric with at least a 5 V working voltage rating. X7R dielectric capacitors provide better temperature stability and are recommended for this application.

### 3.4.8 XFI Transmit Data CML Output

The CML high-speed data output driver consists of a differential pair designed to drive a 50  $\Omega$  transmission line. As shown in the following illustration, the output driver uses an on-chip source termination of 50  $\Omega$  to VDD12TX, which minimizes any reflections.

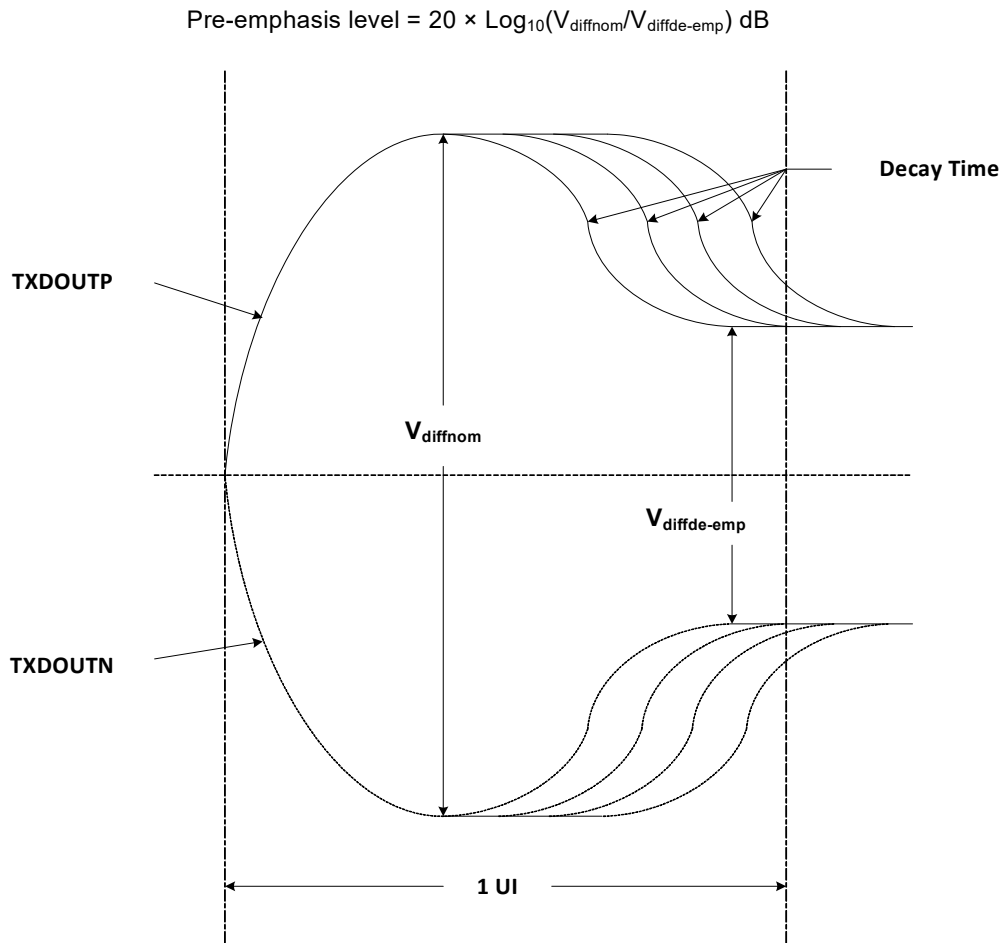
**Figure 20 • CML XFI Output Driver**


For single-ended operation at the transmitter, the unused TXDOUTP or TXDOUTN signal must be terminated either to VDD in DC couple mode or with a resistor to ground in AC couple mode. The resistor to ground must have a value equal to the characteristic impedance of the copper transmission channel. The TXDOUTP/N outputs can be forced to a static level by asserting TXONOFF1 input low.

### 3.4.9 XFI Transmitter Pre-emphasis and Slew Rate

The XFI output stage includes programmable pre-emphasis, which affects the peaking and decay time (slew rate) of the transmitted bit. The following illustration shows the de-emphasized waveform. The illustration is for reference only and is not intended to represent an actual waveform.

**Figure 21 • XFI Data Transmitter Differential Voltage with Pre-emphasis**



When used, transmit pre-emphasis shapes the XFI transmitter signal to mitigate dielectric and skin-effect distortion and loss. When signal pre-emphasis is employed, the effects of peaking pre-distortion offsets dielectric and skin-effect distortion, and a higher quality waveform results at the receiving device.

XFI transmitter pre-emphasis settings are programmed by writing to eight bits in register 1×E601[7:0]. The four least significant bits select the inductive peaking level and the four most significant bits adjust the pre-emphasis ratio. Recommended pre-emphasis settings are shown in the following table, along with approximate ratios.

**Table 15 • XFI Transmitter Pre-emphasis Ratio**

Setting for Pre-emphasis Ratio Bits 1×E601.7:4	Setting for Inductor Bits (Slew Rate) 1×E601.3:0	Approximate Ratios
0000 (default)	0000	1.8 dB
0100	0000	2.7 dB
1000	0000	3.3 dB
1111	0000	3.9 dB
0000 (default)	1111	3.8 dB
0100	1111	4.8 dB

**Table 15 • XFI Transmitter Pre-emphasis Ratio (continued)**

Setting for Pre-emphasis Ratio Bits 1×E601.7:4	Setting for Inductor Bits (Slew Rate) 1×E601.3:0	Approximate Ratios
1000	1111	6.2 dB
1111	1111	6.4 dB

As a guideline, the default setting is normally sufficient to drive 1 to 2 inches of strip-line or micro-strip transmission line in FR-4. XFI channels with transmission lines that exceed about 2 inches can benefit from increased pre-emphasis adjustment.

### 3.4.10 Line Rate Divided Clock Outputs

Several divided-down clocks can be selected to exit the VSC8486-04 at each of two CML clock outputs called CLK64AP/N and CLK64BP/N. Both clock outputs can be disabled using MDIO. CLK64AP/N also has a pin disable: CLK64A\_EN. CLK64AP/N, which is normally used to provide an XFP reference clock, defaults to enabled and routes one sixty-fourth of the CMU clock rate.

Each clock output driver consists of a differential pair designed to drive a 50 Ω transmission line. Like the high-speed clock output, the output drivers are source-terminated on chip (50 Ω to VDD12TX) to absorb any reflections.

For single-ended operation at the transmitter, the unused output signal must be terminated as close as possible to the characteristic impedance of the transmission line used, which is normally 50 Ω.

The CLK64AP/N and CLK64BP/N outputs provide a similar set of clock signals. CLK64AP/N outputs are normally used for the XFP reference clock. The following table shows the enable and select control logic and available clock outputs for CLK64AP/N.

**Table 16 • CLK64AP/N Clock Output**

TCLKA_EN_SRC (1×E602.6)	TCLKA_EN_REG (1×E602.9)	CLK64A_EN Pin	TCLKA_SEL (1×E602.8:7)	CLK64AP/N Output
0	X	0	xx	Disabled
0 (default)	X	1 (default)	00 (default)	CMU clock divided by 64
0	X	1	01	CMU clock divided by 66
0	X	1	10	CRU clock divided by 64
0	X	1	11	REFCK reference clock
1	0 (default)	X	xx	Disabled
1	1	X	00	CMU clock divided by 64
1	1	X	01	CMU clock divided by 66
1	1	X	10	CMU clock divided by 64
1	1	X	11	REFCK reference clock

The following table provides the enable and select control logic and available clock outputs for CLK64BP/N.

**Table 17 • CLK64BP/N Clock Output**

TCLKB_EN (1×E602.5)	TCLKB_SEL (1×E602.4:3)	CLK64BP/N Output
0 (default)	xx	Disabled



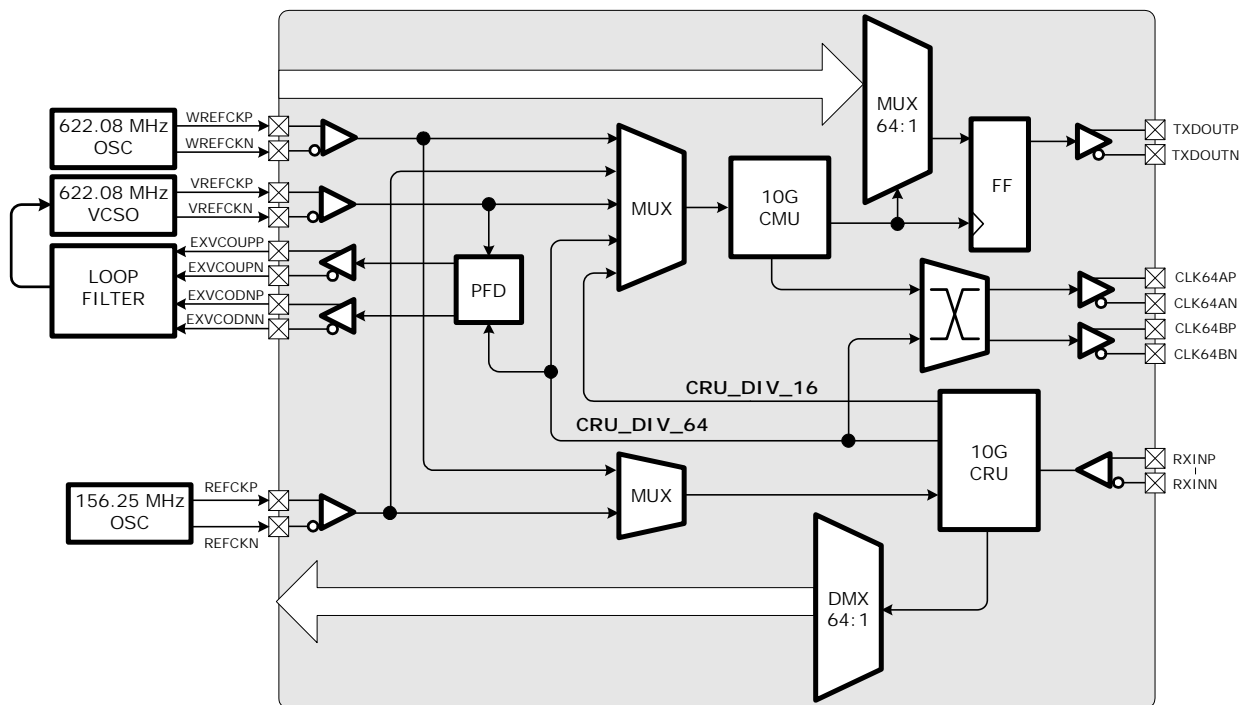
**Table 17 • CLK64BP/N Clock Output (continued)**

TCLKB_EN (1×E602.5)	TCLKB_SEL (1×E602.4:3)	CLK64BP/N Output
1	00 (default)	CRU clock divided by 64
1	01	CMU clock divided by 66
1	10	CMU clock divided by 64
1	11	Test_Clock (factory use only)

### 3.4.11 External Phase Lock Loop

An external phase lock loop (PLL) circuit and low phase noise oscillator can be used to transform the VSC8486-04 IEEE 802.3ae compliant PMA block into a fully GR-253 jitter compliant PMA block in WAN operating mode. The following block diagram shows the required elements.

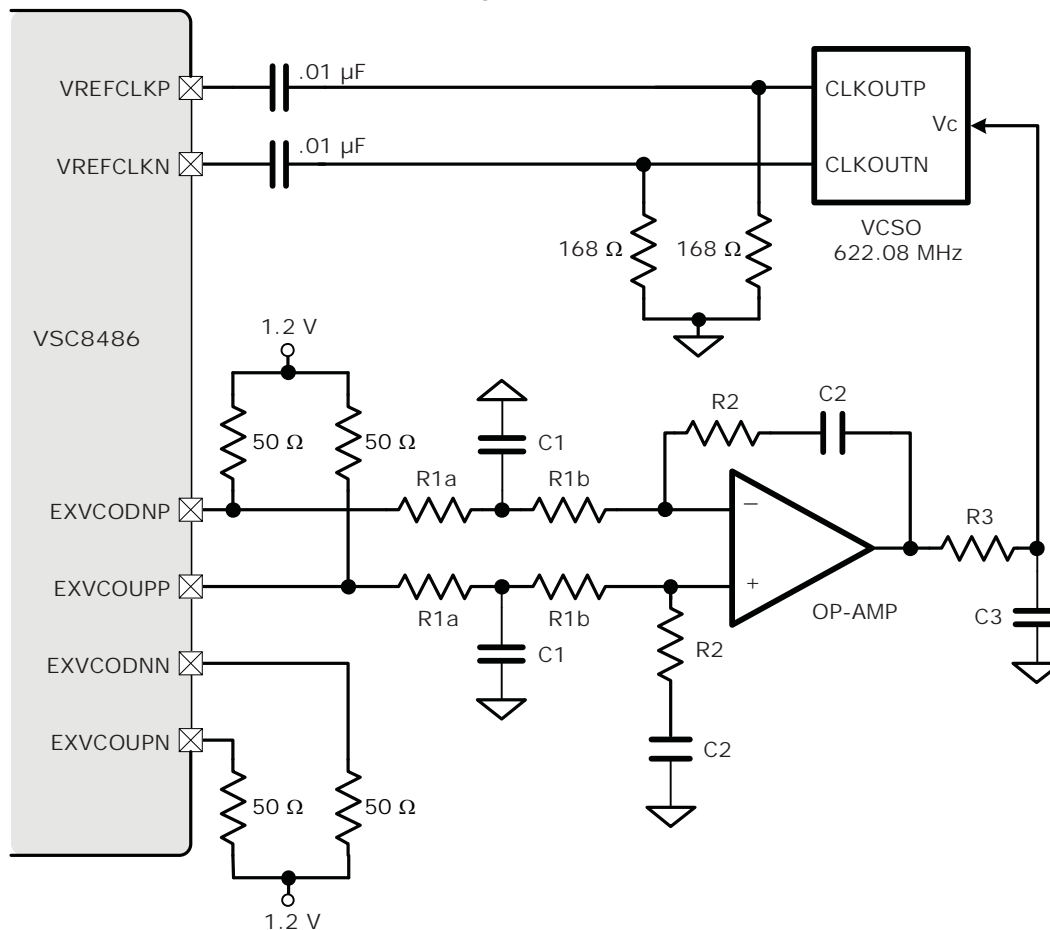
**Figure 22 • SONET Jitter-Compliant Reference Clock Configuration**



The preceding illustration shows the required elements to achieve SONET Terminal Equipment jitter compliance. Reference clocks must operate at the frequencies shown and each of the 622.08 MHz elements must have SONET quality performance specifications, which is normally based on surface acoustic wave (SAW).

The following illustration shows a simple schematic diagram showing the significant elements of a conventional second-order loop filter PLL topology.

Figure 23 • Example External PLL Schematic Diagram



Approximate Filter Values for 100 kHz Loop Bandwidth

$R1 = R1a + R1b$ (k $\Omega$ )	C1 (pF)	R2 (k $\Omega$ )	C2 ( $\mu$ F)	R3 (k $\Omega$ )	C3 (pF)
9.4	22	174	.001	1.0	100

The preceding illustration suggests component values to set the loop bandwidth to approximately 100 kHz since the SONET Jitter Transfer 3 dB point is 120 kHz. These values are intended to provide a point of departure for designers and do not guarantee optimal PLL bandwidth or performance. There are other parameters of the PLL design including, but not limited to, peaking, stability, phase noise and damping ratio, which must be considered and are beyond the scope of this document.

### 3.4.12 High-Speed Serial Data Inputs

The incoming 10.3125 Gbps (LAN) or 10.51875 Gbps (SAN) or 9.953 Gbps (WAN) data is received by high-speed inputs (RXINP/N). The inputs are terminated internally with 50  $\Omega$  to RXINCM, as shown in the following illustration.

This configuration also forms an impedance equivalent to 100  $\Omega$  across the differential pair to terminate the differential mode signal and a center-tapped virtual ground brought out as the RXINCM pin to absorb common-mode noise. The receiver's input common-mode voltage level is programmable by writing to VCM\_ADJ (1×E701.11:6).

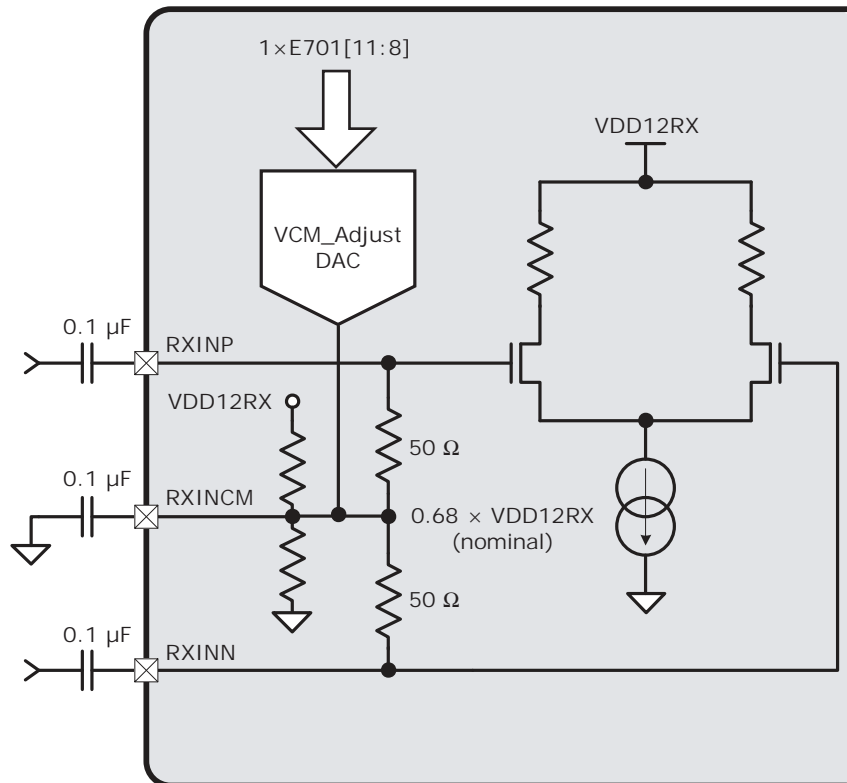
The inputs should be AC-coupled to allow for appropriate common-mode voltage adjustments. The device can optionally be DC-coupled, which requires proper common mode.

The VSC8486-04 is designed to operate with XFI signaling based on nominal 100  $\Omega$  differential impedance and AC coupling. The AC coupling capacitors on the high-speed serial data inputs (RXINP/N)

are expected to be in the XFP module. The RXINCM pin should be AC-coupled to ground through a 0.1  $\mu\text{F}$  capacitor to provide a low impedance AC return path for the 50  $\Omega$  termination.

The VSC8486-04 can also operate in a single-ended mode. The RXINCM pin should be AC-coupled to ground through a 0.1  $\mu\text{F}$  capacitor. The unused input should also be tied to a clean AC ground to prevent the RXINP signal from internally coupling through to RXINN and degrading input sensitivity. The total current through the 50  $\Omega$  resistor is limited to 25 mA; therefore, there should never be more than a 1 V difference between RXINP and RXINCM, or between RXINN and RXINCM.

Figure 24 • CML XFI Data Receiver



### 3.4.13 XFI Data Input Receiver Equalization

Incoming data on the RXINP/N inputs might contain a substantial amount of inter-symbol interference (ISI) or deterministic jitter that reduces the ability of the receiver to recover data without errors. A programmable equalizer is provided in the input buffer to compensate for this deterministic jitter. This circuit is designed to effectively reduce the ISI commonly found in the copper PCB traces of an XFI-compliant channel, which can be as long as 12 inches. Typically for FR-4 materials, low frequencies are attenuated less than high frequencies as a result of the skin effect and dielectric losses. See the channel loss model as defined in the XFP multisource agreement.

The RXIP/N input equalizer includes a 2-bit control for peaking and decay to mitigate the effects of FR-4 losses. Overall receiver equalization response is adjusted by setting the four internal register bits, as shown in the following table.

Typical XFP host applications using less than 2 inches of FR-4 do not require modification of the default settings because the VSC8486-04 default setting includes some intrinsic peaking. For higher loss

tangent material and/or XFI channel physical trace lengths exceeding about 2 inches, changing the equalization settings to match those shown in the following table can offer the best performance.

**Table 18 • Register 1x8002.14:11 RXINP/N Equalization Control**

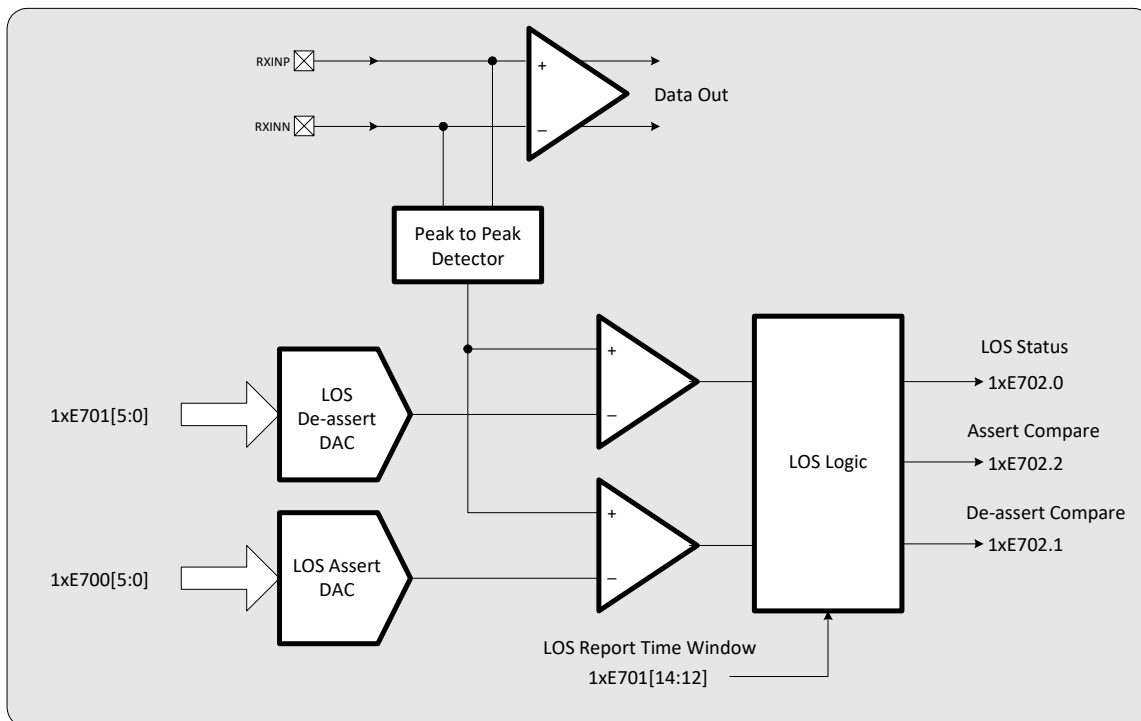
Peaking		Decay		Comment
Bit 14	Bit 13	Bit 12	Bit 11	
1	1	1	1	Default (less than 2 inches of FR-4).
1	1	0	0	Recommended for applications greater than 2 inches of FR-4. Recommendations are based on characterization data. Some applications can have optimal settings that diverge from the recommendations.

### 3.4.14 Loss of Signal

The Loss of Signal (LOS) circuitry utilizes peak-to-peak differential signal detection and selectable independent assert and deassert thresholds to produce an output LOS monitor proportional to the minimum useable signal present at the RXINP/N inputs. The following illustration shows the PMA LOS block diagram.

The LOS peak-to-peak voltage swing detection is determined by directly sensing the input signal at the input pins. The nominal LOS assert voltage is 50 mV. Calibration and adjustment of the LOS assert and deassert levels should be expected, because RXINP/N signals vary by application.

**Figure 25 • PMA LOS Functional Block Diagram**



The following table summarizes register access for the VSC8486-04 PMA LOS functions.

**Table 19 • PMA LOS Register Status and Control Summary**

Register	Name	Function	Remarks
1×E702.0	LOS_STAT	If RXINP/N peak-to-peak signal falls below assert threshold, bit 0 = 1.	
1×E700.5:0	LOS_ASSERT_DAC (VA_OUT)	LOS assert threshold value. Default is minimum (000000).	Set the LOS assert voltage threshold. 001100: Less than 75 mV. 010010: Greater than 110 mV. All else: Reserved.
1×E701.5:0	LOS_DEASSERT_DAC (VDA_OUT)	LOS deassert threshold value. Default is minimum (000000).	Set the LOS deassert voltage threshold. 001100: Less than 75 mV. 010010: Greater than 110 mV. All else: Reserved.
1×E701.14:12	LOS_WIN	LOS reported or cleared when signal falls below assert threshold or remains above the deassert threshold within these approximate time interval limits.	LOS report range is 50 $\mu$ s to 100 $\mu$ s. LOS clear range is 125 $\mu$ s to 250 $\mu$ s. The same 3 bits simultaneously change LOS report and clear times from minimum (000) to maximum (111).
1×E702.1	LOS_DEASSERT_STAT	Bit 1 indicates deassert threshold crossed.	In normal operation, the deassert threshold is crossed when the peak-to-peak signal is increased following an LOS report.
1×E702.2	LOS_ASSERT_STAT	Bit 2 indicates assert threshold crossed.	In normal operation, the assert threshold is crossed when the peak-to-peak signal falls below a useable range. This range might require adjustment.
1×E701.15	LOS_PWR_DWN	Bit 15 set to 1 disables PMA LOS.	Default is LOS enabled, bit 15 = 0.

### 3.4.15 Loss of Optical Carrier

LOPC is an input pin for the VSC8486-04 that is normally connected to the XFP LOS output. Any change in level on the LOPC input asserts LOPC\_PEND (2×EF04.11) until read. The current status of the LOPC input pin can be read using LOPC\_STAT (2×EF03.11). The LOPC input can be active high or active low by setting the LOPC\_POL\_SEL (2×EC30.9) bit appropriately. The LOPCS\_PEND bit can propagate an interrupt to either WIS\_INTA or WIS\_INTB based upon mask-enabled bits LOPC\_MASKA (2×EF05.11) and LOPC\_MASKB (2×EF06.11). For WIS applications, the LOPC input can be configured to initiate a line remote defect indication (RDI-L).

## 3.5 WAN Interface Sublayer

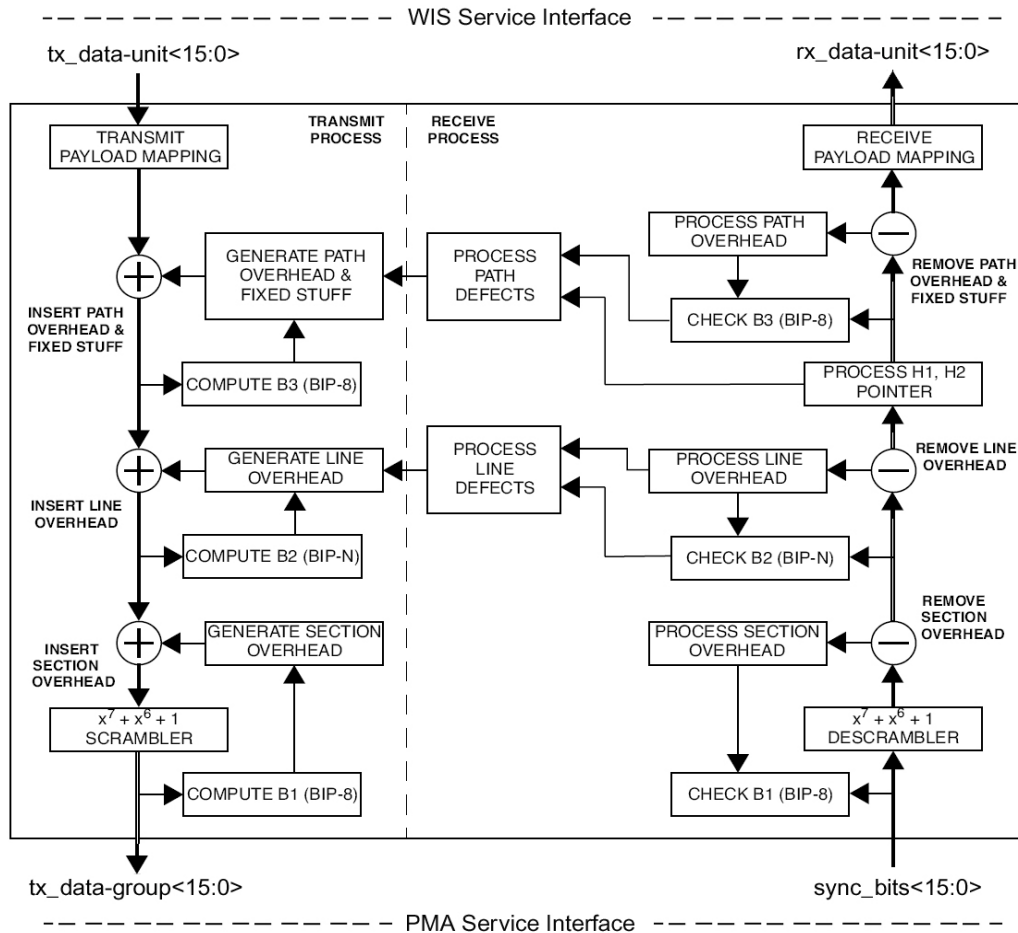
The WAN interface sublayer (WIS) is defined in IEEE Standard 802.3ae Clause 50. The VSC8486-04 WIS block is fully compliant with this specification. The VSC8486-04 offers additional controls, ports, and registers to allow integration into a wider array of SONET/SDH equipment. Clocking requirements are a critical component for SONET/SDH equipment as discussed in earlier sections.

In addition to the SONET/SDH features addressed by WIS as defined by IEEE, most SONET/SDH framers/mappers contain additional circuitry for implementing Operation, Administration, Maintenance and Provisioning (OAM&P). These framers/mappers also support special features to enable compatibility with legacy SONET/SDH solutions. Because the VSC8486-04 WIS leverages Microsemi's industry-leading framer/mapper technology it contains suitable features for standard SONET/SDH equipment. This includes the Transmit/Receive Overhead Serial Interfaces (TOSI/ROSI) commonly used for network customization and OAM&P, support for SONET/SDH errors not contained in the WIS standard, support for common legacy SONET/SDH implementations, and SONET/SDH jitter and timing quality.

### 3.5.1 Operation

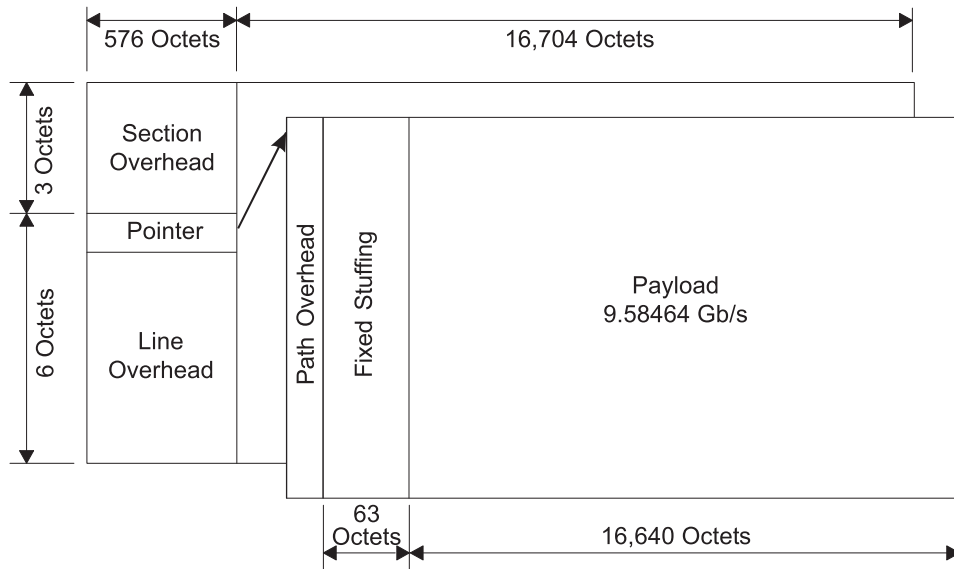
The transmit portion of the WIS maps data from the PCS through the WIS service interface and to the SONET/SDH synchronous payload envelope (SPE). It then generates path, line, and section overhead octets, scrambles the frame, and transmits the frame to the PMA Service Interface. The receive portion of the WIS does the following: receives data from the PMA service interface; delineates octet and frame boundaries; descrambles the frame; processes section, line, and path overhead information that contain alarms and parity errors; interprets the pointer field; and extracts the payload for transmittal to the PCS through the WIS service interface. The WIS block diagram is shown in the following illustration.

Figure 26 • WIS Transmit and Receive Functions



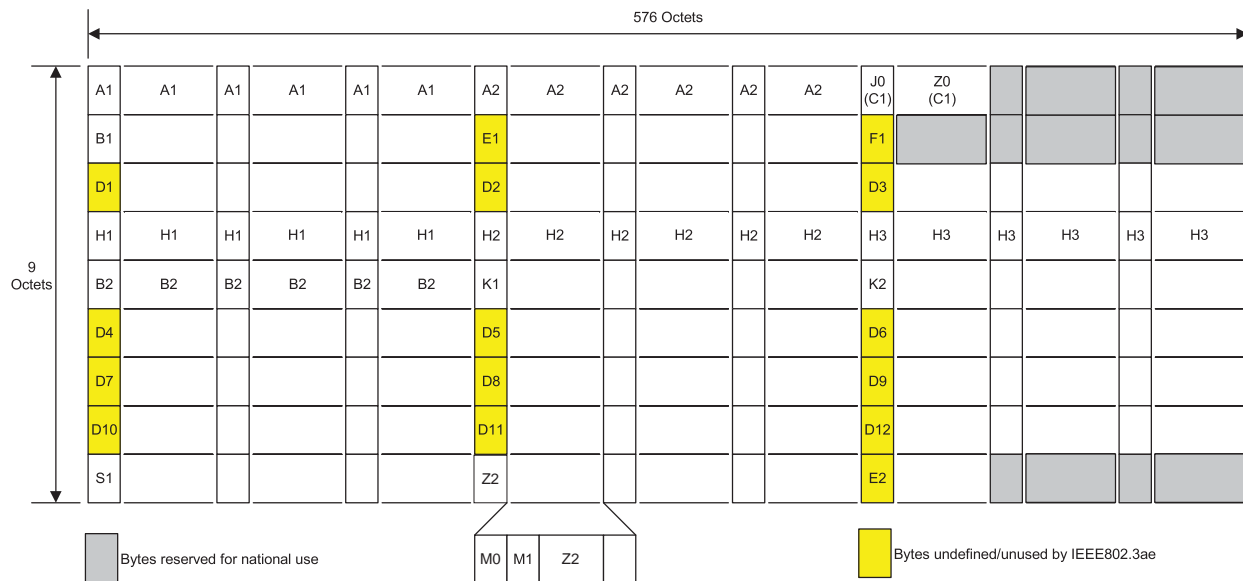
The WIS frame structure is shown in the following illustration.

**Figure 27 • WIS Frame Structure**

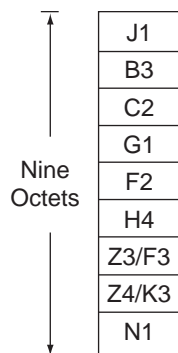


The positions of the section and line overhead octets within the WIS Frame are shown in the following illustration.

**Figure 28 • STS-192c/STM-64 Section and Line Overhead Structure**



The path overhead octet positions are depicted in the following illustration.

**Figure 29 • Path Overhead Octets**

### 3.5.2 Section Overhead

The section overhead portion of the SONET/SDH frame supports frame synchronization, a tandem connection monitor (TCM) known as the Section trace, a high-level parity check, and some OAM&P octets. The following table lists each of the octets including their function, specification, and related information.

The VSC8486-04 provides a mechanism to transmit a static value as programmed by the MDIO interface. However, by definition, MDIO is not fast enough to alter the octet on a frame-by-frame basis.

**Table 20 • Section Overhead**

Overhead Octet	Function	IEEE 802.3ae WIS Usage	Recommended Value	WIS Extension
A1	Frame alignment	Supported	0xF6	Register (2×E611) TOSI and ROSI access.
A2	Frame alignment	Supported	0x28	Register (2×E611) TOSI and ROSI access.
J0	Section trace	Specified value	See the discussion of J0 (Section Trace)	A 1-byte, 16-byte, or 64-byte trace message can be sent using registers 2×0040 to 2×0047, 2×E700, or 2×E800 to 2×E817 and received using registers 2×0048 to 2×004F, 2×EC20, and 2×E900 to 2×E917. TOSI and ROSI access.
Z0	Reserved for section growth	Unsupported	0xCC	Register 2×E612 TOSI and ROSI access.
B1	Section error monitoring (Section BIP-8)	Supported	Bit interleaved parity - 8 bits, as specified in T1.416	Using the TOSI, the B1 byte can be masked for test purposes. For each B1 mask bit that is cleared to 0 on the TOSI interface, the transmitted bit is left unchanged. For each B1 mask bit that is set to 1 on the TOSI interface, the transmitted bit is inverted. Using the ROSI, the B1 error locations can be extracted. Periodically latched counter (2×ECB0-2×ECB1) is available.
E1	Orderwire	Unsupported	0x00	Register 2×E612 TOSI and ROSI access.
F1	Section user channel	Unsupported	0x00	Register 2×E613 TOSI and ROSI access.
D1-D3	Section data communications channel (DCC)	Unsupported	0x00	Register 2×E613 to 2×E614 TOSI and ROSI access.

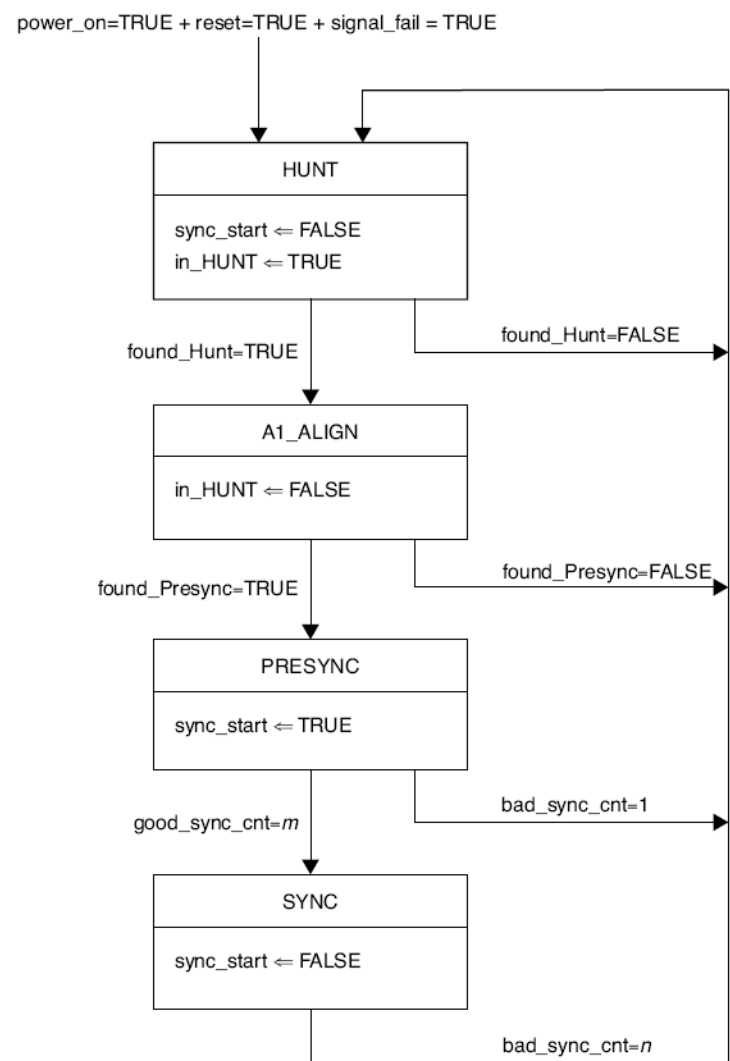


### 3.5.2.1 A1, A2 (Frame Alignment)

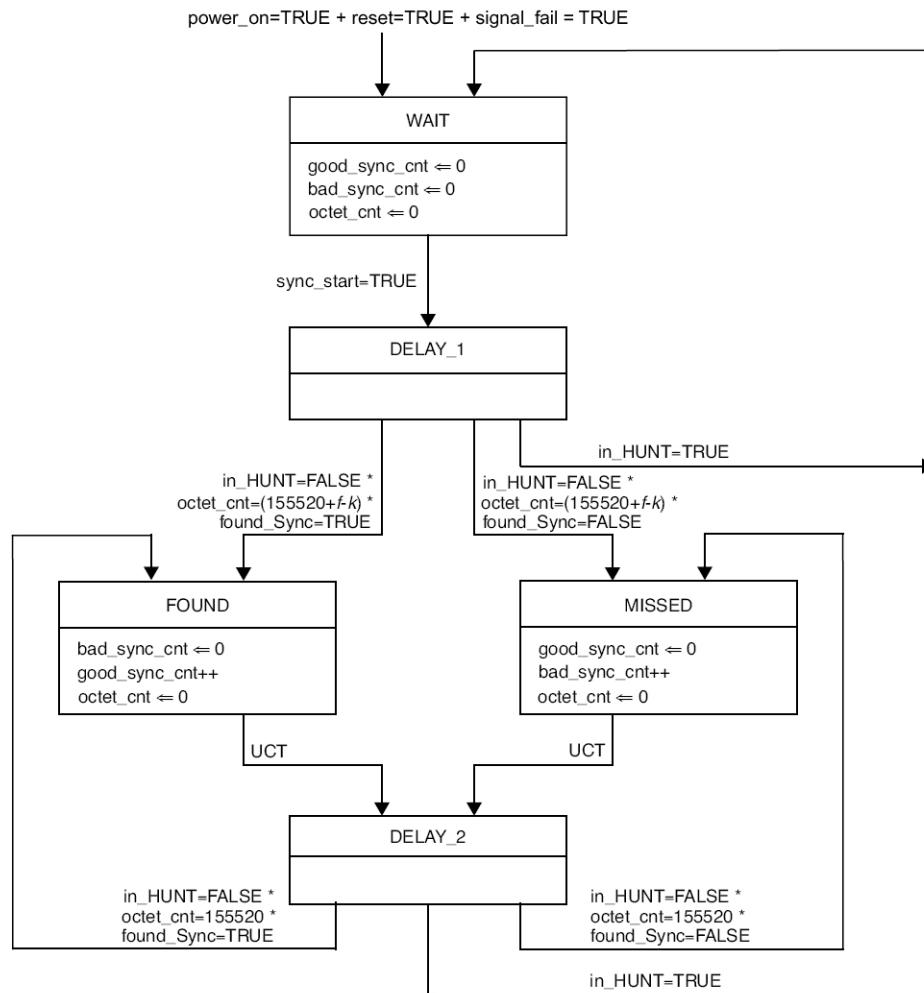
The SONET/SDH protocol is based upon a frame structure which is delineated by the framing octets, A1 and A2. The framing octets are defined to be 0xF6 and 0x28 respectively. In the transmit direction all 192 A1 octets are sourced from the TX\_A1 (2xE611.15:8) register while the A2 octets are sourced from the TX\_A2 (2xE611.7:0) register.

In the receive direction, the frame aligner monitors the input bus from the PMA and performs word alignment. The frame alignment architecture is composed of a primary and secondary state machine. The primary state diagram is shown in the following illustration and the variables for the primary state diagram are shown in the following table. The variables are reflected in registers EWIS\_RX\_FRM\_CTRL1 (2xEC00) and EWIS\_RX\_FRM\_CTRL2 (2xEC01) that can be alternately reconfigured. The selected frame alignment and synchronization pattern have implications on the tolerated input BER. The higher the input BER, the less likely the frame boundary can be found. The chances of finding the frame boundary are improved by reducing the number of A1/A2 bytes required to be detected (using a smaller pattern width). According to the WIS specification, the minimum for all parameters allows a signal with an error tolerance of  $10^{-12}$  to be framed.

**Figure 30 • Primary Synchronization State Diagram**



**Figure 31 • Secondary Synchronization State Diagram**



The following table describes the variables for the primary state diagram.

**Table 21 • Framing Parameter Description and Values**

Name	Description	IEEE 802.3ae Parameter	IEEE 802.3ae Range	VSC8486-04 Range	VSC8486-04 Default
Sync_Pattern width	Sequence of f consecutive A1s followed immediately by a sequence of f consecutive A2s. If f = 2, Sync_Pattern is A1A1A2A2.	f	2 to 192	0 to 16. Exceptions: If f = 0, Sync_Pattern is A1 + 4 MSBs of A2. If f = 1, Sync_Pattern is A1A1A2.	2
Hunt_Pattern width	Sequence of i consecutive A1s.	i	1 to 192	1 to 16.	4
Presync_Pattern A1 width	Presync_Pattern consists of a sequence of j consecutive A1s followed immediately by a sequence of k consecutive A2s.	j	16 to 190	1 to 16. If set to 0, behaves as if set to 1. If set to 17 to 31, behaves as if set to 16.	16

**Table 21 • Framing Parameter Description and Values (continued)**

Name	Description	IEEE 802.3ae Parameter	IEEE 802.3ae Range	VSC8486-04 Range	VSC8486-04 Default
Presync_Pattern A2 width	Presync_Pattern consists of a sequence of j consecutive A1s followed immediately by a sequence of k consecutive A2s.	k	16 to 192	0 to 16. 0 means only 4 MSB of A2 are used. If set to 17 to 31, behaves as if set to 16.	16
SYNC state entry	Number of consecutive frame boundaries needed to be found after entering the PRESYNC state in order to enter the SYNC state.	m	4 to 8	1 to 15. If set to 0, behaves as if set to 1.	4
SYNC state exit	Number of consecutive frame boundary location errors detected before exiting the SYNC state.	n	1 to 8	1 to 15. If set to 0, behaves as if set to 1.	4

### 3.5.2.2 Loss of Signal (LOS)

The SONET/SDH Loss of Signal (LOS) alarm is tied to the PMA input receiver logic discussed in [Loss of Signal](#), page 31. The LOS (2×0021.6) alarm is a latch-high register; back-to-back reads provide both the event as well as status information. The LOS event also asserts the LOS\_PEND (2×EF00.6) until read. This event can propagate an interrupt to either WIS\_INTA or WIS\_INTB based upon mask enable bits LOS\_MASKA (2×EF01.6) and LOS\_MASKB (2×EF02.6).

When the near end device experiences a LOS condition, it is possible to automatically transmit a remote defect indication (RDI-L) to the far end for notification purposes. The TXRDIL\_ON\_LOS (2×EE00.2), if asserted, overwrites the outgoing K2 bits with the RDI-L code. In the receive path, it is possible to force a AIS-L state (alarm assertion plus forcing the payload to an all ones state) upon a detection of an LOS condition. This is accomplished by asserting RXAISL\_ON\_LOS (2×EE00.5).

### 3.5.2.3 Loss of Optical Carrier (LOPC)

The input pin LOPC can be used by external optic components to directly assert the loss of optical power to the physical media device. Any change in level on the LOPC input asserts LOPC\_PEND (2×EF04.11) until read. The current status of the LOPC input pin can be read using LOPC\_STAT (2×EF03.11). The LOPC input can be active high or active low by setting the LOPC\_POL\_SEL (2×EC30.9) bit appropriately. The LOPCS\_PEND bit can propagate an interrupt to either WIS\_INTA or WIS\_INTB based upon mask enable bits LOPC\_MASKA (2×EF05.11) and LOPC\_MASKB (2×EF06.11).

When the near end device experiences an LOPC condition, it is possible to automatically transmit a remote defect indication (RDI-L) to the far end to notify it of a problem. The TXRDIL\_ON\_LOPC (2×EE00.3), if asserted, overwrites the outgoing K2 bits with the RDI-L code. In the receive path, it is possible to force the receive framer into an LOF state, thereby squelching subsequent alarms and invalid payload data processing. This is accomplished by asserting RXLOF\_ON\_LOPC (2×EC30.8). Similar to the LOF condition forced upon an LOPC, the RXAISL\_ON\_LOPC (2×EE00.6) can force the AIS-L alarm assertion, plus force the payload to an all ones state to indicate to the PCS the lack of valid data, upon an LOPC condition.

### 3.5.2.4 Severely Errored Frame (SEF)

Upon reset, the VSC8486-04 enters the out of frame (OOF) state with both the severely errored frame (SEF) and loss of frame (LOF) alarms active. The SEF defect is terminated when the framer enters the SYNC state. The framer enters the SYNC state after SYNC\_ENTRY\_CNT (2×EC01.7:4) plus 1

consecutive frame boundaries are identified. A SEF defect state is declared when the framer enters the out-of-frame (OOF) state. The frame changes from the SYNC state to the OOF state when SYNC\_EXIT\_CNT (2×EC01.3:0) consecutive frames with errored frame alignment words are detected. SEF is indicated by asserting SEF (2×0021.11). This register latches high providing a combination of interrupt pending and status information within consecutive reads.

An additional bi-stable interrupt pending bit SEF\_PEND (2×EF00.11) is provided which can propagate an interrupt to either WIS\_INTA or WIS\_INTB based upon mask enable bits SEF\_MASKA (2×EF01.11) and SEF\_MASKB (2×EF02.11).

### 3.5.2.5 Loss of Frame (LOF)

An LOF occurs when an out of frame state persists for an integrating period of LOF\_T1 (2×EC02.11:6) frames. To provide for the case of intermittent OOFs, when not in the LOF state, the integrating timer is not reset to zero until an in-frame condition persists continuously for LOF\_T2 (2×EC02.5:0) frames. Once in the LOF state, this state is left when the in-frame state persists continuously for LOF\_T3 (2×EC03.6:1) frames. The LOF state is indicated by LOF (2×0021.7) being asserted. This register latches high, providing a combination of pending and status information over consecutive reads.

An additional bi-stable interrupt pending bit LOF\_PEND (2×EF00.7) is provided which can propagate an interrupt to either WIS\_INTA or WIS\_INTB based upon mask enable bits LOF\_MASKA (2×EF01.7) and LOF\_MASKB (2×EF02.7).

When the near end device experiences an LOF condition, it might be required that the far end device be notified of the catastrophic condition. Transmitting an alarm indication signal (AIS-L) can accomplish this. If AISL\_on\_LOF (2×EE00.4) is asserted, the transmit path is preempted by the AIS-L pattern whenever an LOF alarm condition is asserted.

When the near end device experiences an LOF condition, it is possible to automatically transmit a remote defect indication (RDI-L) to the far end to notify it of a problem. The TXRDIL\_ON\_LOF (2×EE00.1), if asserted, overwrites the outgoing K2 bits with the RDI-L code. In the receive path, it is possible to force a AIS-L state (alarm assertion plus forcing the payload to an all ones state) upon a detection of an LOF condition. This is accomplished by asserting RXAISL\_ON\_LOF (2×EE00.4).

### 3.5.2.6 J0 (Section Trace)

The J0 octet often carries a repeating message called the Section Trace Message. The default transmitted message length is 16-octets whose contents are defined in J0\_TXMSG (2×0040-2×0047). If no active message is being broadcast, a default Section Trace Message consisting of 15 octets of zeros and a header octet formatted according to Section 5 of ANSI T1.269-2000 shall be transmitted. The header octet for the 15-octets of zero would be 0×89.

The J0 octet in the receive direction by default is assumed to be carrying a 16-octet continuously repeating Section Trace Message. The message is extracted from the incoming WIS frames and stored in J0\_RXMSG (2×0048-2×004F). The WIS receive process does not delineate the message boundaries, thus the message might appear rotated between new frame alignment events.

The VSC8486-04 supports two alternate message types, a single repeating octet and a 64-octet message. The message type can be independently selected for the transmit and receive direction. The transmit direction is configured using J0\_TXLEN (2×E700.3:2) while J0\_RXLEN (2×EC20.3:2) configures the receive path.

When the transmit direction is configured for a 64-octet message the first 16 octets are programmed in J0\_TXMSG (2×0040-2×0047) while the 48 remaining octets are programmed in J0\_TXMSG64 (2×E800-2×E817). Likewise, the first 16 octets of the receive message are stored in J0\_RXMSG (2×0048-2×004F) while the other 48 octets are stored in J0\_RXMSG64 (2×E900-2×E917). The receive message is updated every 125 μs with the recently received octet. Any persistency or message matching is expected to take place within the station manager.

### 3.5.2.7 Z0 (Reserved for Section Growth)

The WIS standard does not support the Z0 octet and requires transmission of 0×CC in the octet locations. A different Z0 value can be transmitted by configuring TX\_Z0 (2×E612.15:8). The TX\_Z0 default is 0×CC.

### 3.5.2.8 Scrambling/Descrambling

The transmit signal (except for row 1 of the section overhead) is scrambled according to the standards when SCR\_EN (2×E600.12) is asserted, which is the default state. When deasserted, the scrambler is disabled.

The receive signal descrambler DESCEN (2×EC10.1) is enabled by default; however, by deasserting this bit the descrambler can be bypassed.

### 3.5.2.9 B1 (Section Error Monitoring)

The B1 octet is a bit interleaved parity-8 (BIP-8) code using even parity calculated over the previous STS-192c frame, post scrambling. The computed BIP-8 is placed in the following outgoing SONET frame before scrambling.

In the receive direction, the incoming frame is processed and a BIP-8 is calculated. The calculated value is then compared with the B1 value received in the following frame. The difference between the calculated and received octets are accumulated into B1\_CNT (2×003C). This counter rolls over after the maximum count. This counter is cleared upon device reset.

The B1\_ERR\_CNT[1:0] (2×ECB0 to 2×ECB1) registers provide a count of the number of received B1 parity errors. This register is updated with the internal count value upon a PMTICK condition, after which the internal counter is reset to zero. When the counter is nonzero, the B1\_NZ\_PEND (2×EF04.7) event is asserted until read. A non-latch high version of this event, B1\_NZ\_STAT (2×EF03.7) is also available. This event can propagate an interrupt to either WIS\_INTA or WIS\_INTB based upon mask enable bits B1\_ERR\_MASKA (2×EF05.7) and B1\_ERR\_MASKB (2×EF06.7).

The B1\_ERR\_CNT can optionally be configured to increment on a block count basis, a maximum increment of 1 per errored frame regardless of the number of errors received. This mode is enabled by asserting B1\_BLK (2×EC61.11)

### 3.5.2.10 E1 (Section Orderwire)

The WIS standard does not support the E1 octet and requires transmission of 0×00 in the octet location. A different E1 value can be transmitted by configuring TX\_E1 (2×E612.7:0) whose default is 0×00.

### 3.5.2.11 F1 (Section User Channel)

The WIS standard does not support the F1 octet and requires transmission of 0×00 in the octet location. A different F1 value can be transmitted by configuring TX\_F1 (2×E613.15:8) whose default is 0×00.

### 3.5.2.12 DCC-S (Section Data Communication Channel)

The WIS standard does not support the DCC-S octets and requires transmission of 0×00 in the octet locations. Different DCC-S values can be transmitted by configuring TX\_D1 (2×E613.7:0), TX\_D2 (2×E614.15:8), and TX\_D3 (2×E614.7:0), all of which default to 0×00.

### 3.5.2.13 Reserved, National and Unused Octets

The VSC8486-04 transmits 0×00 for all Reserved, National, and unused overhead octets.

## 3.5.3 Line Overhead

The line overhead portion of the SONET/SDH frame supports pointer interpretation, a per channel parity check, protection switching information, synchronization status messaging, far end error reporting, and some OAM&P octets. The following table lists each of the octets including their function, specification, and related information.

The VSC8486-04 provides a mechanism to transmit a static value as programmed by the MDIO interface. However, by definition, MDIO is not fast enough to alter the octet on a frame-by-frame basis.

**Table 22 • Line Overhead Octets**

Overhead Octet	Function	IEEE 802.3ae WIS Usage	Recommended Value	WIS Extension
H1-H2	Pointer	Specified value	SONET mode: STS-1: 0×62, 0×0A STS-n: 0×93, 0×FF  SDH mode: STS-1: 0×6A, 0×0A STS-n: 0×9B, 0×FF	Register 2×E615 to 2×E616 TOSI and ROSI access.
H3	Pointer action	Specified value	0×00	Register 2×E616 TOSI and ROSI access.
B2	Line error monitoring (line BIP-1536)	Supported	Bit interleave parity-8, as specified in T1.416	Using the TOSI, the B2 bytes can be masked for test purposes. For each B2 mask bit that is cleared to 0 on the TOSI interface, the transmitted bit is left unchanged. For each B2 mask bit that is set to 1 on the TOSI interface, the transmitted bit is inverted. Using the ROSI, the B2 error locations can be extracted. Periodically latched counter (2×ECB0-2×ECB1) is available.
K1, K2	Automatic protection switch (APS) channel and line remote defect identifier (RDI-L)	Specified value	For information about K2 coding, see <a href="#">Table 23</a> , page 43	Register 2×E617 to 2×E618 TOSI and ROSI access.
D4-D12	Line data communications channel (DCC)	Unsupported	0×00	Register 2×E619 to 2×E61E TOSI and ROSI access.
S1	Synchronization messaging	Unsupported	0×0F	Register 2×E61F TOSI and ROSI access.
Z1	Reserved for Line growth	Unsupported	0×00	Register 2×E61F TOSI and ROSI access.
M0/M1	STS-1/N line remote error indication (REI)	M0 unsupported, M1 supported	0×00/number of detected B2 errors in the receive path, as specified in T1.416	TOSI and ROSI access. The VSC8486-04 supports a mode that uses only M1 to back report REI-L (REI_MODE = 0) and another mode which uses both M0 and M1 to back report REI-L (REI_MODE = 1). For more information, see the following B2 text.
E2	Orderwire	Unsupported	0×00	Register 2×E620 TOSI and ROSI access.
Z2	Reserved for Line growth	Unsupported	0×00	Register 2×E620 TOSI and ROSI access.

### 3.5.3.1 B2 (Line Error Monitoring)

The B2 octet is a BIP-8 value calculated over each of the previous STS-1 channels excluding the section overhead and pre-scrambling. As the B2 octet is calculated on an STS-1 basis there are 192 B2 octets

within an STS-192/STM-64 frame. Each of the 192 calculated BIP-8 octets are then placed in the outgoing SONET/SDH frame.

**Note:** For SONET mode, the number of detected B2 errors going into an accumulator will be limited to 255 if more than 255 errors are detected in a frame. The Tx framer pulls the REI-L count out of the accumulator when REI-L is transmitted to be compliant with T1-105.

In the receive direction, the incoming frame is processed, and a per STS-1 BIP-8 is calculated (excluding section overhead and after descrambling) and then compared to the B2 value in the following frame. Errors are accumulated into a 32-bit counter B2\_CNT (2×0039-2×003A). This counter is non-saturating and so rolls over after its maximum count. The counter is cleared only on device reset.

An additional 32-bit B2 error counter is provided at B2\_ERR\_CNT (2×ECB2-2×ECB3), which is a saturating counter and is latched and cleared based upon a PMTICK event. Errors are accumulated since the previous PMTICK event. When the counter is nonzero, the B2\_NZ\_PEND (2×EF04.6) event is asserted until read. A non-latch high version of this event B2\_NZ\_STAT (2×EF03.6) is also available. This event can propagate an interrupt to either WIS\_INTA or WIS\_INTB, based on mask enable bits B2\_ERR\_MASKA (2×EF05.6) and B2\_ERR\_MASKB (2×EF06.6).

The B2\_ERR\_CNT can optionally be configured to increment on a block count basis, a maximum increment of 1 per errored frame regardless of the number of errors received. This mode is enabled by asserting B2\_BLK (2×EC61.10).

It is possible that two sets of B2 bytes (from two SONET/SDH frames) are received by the Rx WIS logic in a period of time when only one M0/M1 octet is transmitted. In this situation, one of the two B2 error counts delivered to the Tx WIS logic is discarded. This situation occurs when the receive data rate is faster than the transmit data rate. Similarly, when the transmit data rate is faster than the receive data rate, a B2 error count is not available for REI-L insertion into the M0/M1 octets of the transmitted SONET/SDH frame. A value of zero is transmitted in this case. This behavior is achieved by using a FIFO to transfer the detected B2 error count from the receive to transmit domains.

A FIFO overflow or underflow condition is not considered an error. Instead it is recovered from gracefully as described above. A FIFO overflow or underflow eventually occurs unless the transmit and receive interfaces are running at the same average data rate. Because the received and transmitted frames can differ by, at most, 40 ppm (±20 ppm) and still meet the industry standards, this “slip” can happen no more often than once every 3.1 seconds.

### 3.5.3.2 K1, K2 (APS Channel and Line Remote Defect Identifier)

The K1 and K2 octets carry information regarding Automatic Protection Switching (APS) and Line Remote Defect Identifier (RDI-L). The K1 octet and the most significant five bits of the K2 octet contain the APS channel information. The transmitted values can be configured at TX\_K1 (2×E617.7:0) and TX\_K2 (2×E618.15:8). The default values of all zeros are compliant with the WIS standard.

The three least significant bits within the K2 octet carry the RDI-L encoding, as defined by section 7.4.1 of ANSI T1.416-1999 and as shown in the following table.

**Table 23 • K2 Encodings**

Indicator	K2 Value for Bits 6, 7, 8	Interpretation
RDI-L	110	Remote error indication.  For the receive process, an RDI-L defect occurs after a programmable number of RDI-L signals are received in contiguous frames and is terminated when no RDI-L is received for the same number of contiguous frames. An RDI-L can be forced by asserting FRC_RX_RDIL (2×2×EC30.2).  For the transmit process, the WIS standard does not indicate when or how to transmit RDI-L. VSC8486-04 provides the option of transmitting K2 by programming it through the TOSI, by programming it using the K2_TX MDIO register, or by programming it based on the contents of the K2_TX register with bits 6, 7, and 8 modified depending on the status of the following: LOPC, LOS, LOF, AIS-L and their associated transmit enable bits TXRDIL_ON_LOPC (2×EE00.3), TXRDIL_ON_LOS (2×EE00.2), TXRDIL_ON_LOF (2×EE00.1), and TXRDIL_ON_AISL (2×EE00.0).
AIS-L	111	Alarm indication signal (line).  For the receive process, this is detected based on the settings of the K2 byte. When AIS-L is detected, the WIS link status is down and MDIO register 2×0021.4 is set high. This also contributes to errored second (ES) and severally errored second (SES) reports.  For standard WIS operation, this is never transmitted.
Idle (normal)	000	Unless RDI-L exists, the standard WIS transmits idle.

Although the transmission of RDI-L is not explicitly defined within the WIS standard, the VSC8486-04 allows the automatic transmission of RDI-L upon the detection of LOPC, LOS, LOF, or AIS-L conditions. These features are enabled by asserting RDIL\_ON\_LOPC (2×EE00.3), RDIL\_ON\_LOS (2×EE00.2), RDIL\_ON\_LOF (2×EE00.1), and RDIL\_ON\_AISL (2×EE00.0).

**Note:** The RDI-L code of 110 is transmitted by the DUT only when Rx AIS-L is asserted. For example, if AIS-L is detected by the DUT for five continuous frames in the Rx direction, then the RDI-L code is transmitted for at least 20 frames in the Tx direction, as stated in the ANSI T1.105 specification.

The VSC8486-04 can force an RDI-L condition independent of the K2 transmit value by asserting FRC\_RDIL (2×E600.2). Likewise, an AIS-L condition can be forced by asserting FRC\_AISL (2×E600.1). If both conditions are forced, the AIS-L value is transmitted.

In the receive direction, the RDI-L alarm (K2[6:8] = 110, using SONET nomenclature) and the AIS-L alarm (K2[6:8] = 111, using SONET nomenclature) are not asserted until the condition persists for a programmable number of contiguous frames. This value is programmable at APS\_THRES (2×EC30.7:4) and is typically set to values of 5 or 10. The AIS-L is detected by the receiver after the programmable number of frames is received, and results in the reporting of AIS-P.

The WIS standard defines RDIL (2×0021.5) and AISL (2×0021.4) as a read only latch-high register, so a read of a one in this register indicates that an error condition occurred since the last read. A second read of the register provides the current status of the event as to whether the alarm is currently asserted. RDIL\_PEND (2×EF00.5) and AISL\_PEND (2×EF00.4) assert whenever the RDI-L or AIS-L state changes (assert or deassert). These interrupts have associated mask enable bits,



RDIL\_MASK/AISL\_MASK (2×EF01.5:4/2×EF02.5:4), which, if enabled, propagate an interrupt to the WIS\_INTA/B pins.

For test purposes, the VSC8486-04 can induce an RDI-L condition in the receive direction independent of the received K2 value by asserting FRC\_RX\_RDIL (2×EC30.2). Likewise, an AIS-L condition can be forced in the receive direction by asserting FRC\_RX\_AISL (2×EC30.3).

### 3.5.3.3 AISFORCE Pin

When set high, the AISFORCE pin generates a near end AIS-L defect.

### 3.5.3.4 D4 to D12 (Line Data Communications Channel)

The WIS standard does not support Line Data Communications Channel (L-DCC) octets (D4-D12) and recommends transmitting 0×00 within these octets. The D4-D12 transmitted values can be programmed at (2×E619-2×E61E). The register defaults are all 0×00. The receive L-DCC octets are only accessible through the ROSI port.

### 3.5.3.5 M0 and M1 (STS-1/N Line Remote Error Indication)

The M0 and M1 octets are used for back reporting the number of B2 errors received, known as remote error indication (REI-L). The value in this octet comes from the B2 error FIFO, as discussed with the B2 octet. The WIS standard does not support the M0 octet and recommends transmitting 0×00 in place of the M0 octet. However, the WIS standard supports the M1 octet in accordance with T1.416.

Two methods for back-reporting exist and are controlled by G707\_2000\_REIL (2×EC40.12). Because a single frame can contain up to 1536 B2 errors while the M1 byte alone can only back report a maximum of 255 errors, a discrepancy exists. When G707\_2000\_REIL is deasserted, only the M1 byte is used and a maximum of 255 errors are back-reported. When G707\_2000\_REIL is asserted, two octets per frame are used for back reporting, the M1 octet and the M0 octet (not the first STS-1 octet, but the second STS-1 octet). In this mode, a total of 1536 errors can be back-reported per frame.

In the receive direction the VSC8486-04 detects and accumulate errors according to the G707\_2000\_REIL setting. The VSC8486-04 deviates from the G.707 standard by not interpreting REI-L values greater than 1536 as zero. The WIS standard defines a 32-bit REI-L counter REIL\_CNT (2×0037-2×0038). This counter is non-saturating and so rolls over after its maximum count. The counter is cleared only on device reset.

An additional 32-bit REI-L counter is provided at REIL\_ERR\_CNT (2×EC90-2×EC91) which is a saturating counter and is latched and cleared based upon a PMTICK event. Errors are accumulated since the previous PMTICK event. When the counter is nonzero, the REIL\_NZ\_PEND (2×EF04.2) event is asserted until read. A non-latch high version of this event REIL\_NZ\_STAT (2×EF03.2) is also available. This event can propagate an interrupt to either WIS\_INTA or WIS\_INTB based upon mask enable bits REIL\_NZ\_MASKA (2×EF05.2) and REIL\_NZ\_MASKB (2×EF06.2).

The REIL\_ERR\_CNT can optionally be configured to increment on a block count basis, a maximum increment of 1 per errored frame regardless of the number of errors received. This mode is enabled by asserting REIL\_BLK (2×EC61.4).

### 3.5.3.6 S1 (Synchronization Messaging)

The S1 octet carries the synchronization status message and provides synchronization quality measures of the transmission link in the least significant 4 bits. The WIS standard does not support the S1 octet and requires the transmission of a 0×0F within the S1 octet. A value other than 0×0F can be programmed in TX\_S1 (2×E61F).

### 3.5.3.7 Z1 and Z2 (Reserved for Line Growth)

The WIS standard does not support the Z1 or Z2 octets and requires the transmission of 0×00 in their locations. Different Z1 and Z2 values can be transmitted by programming the values at TX\_Z1 (2×E61F) and TX\_Z2 (2×E620) respectively.

### 3.5.3.8 E2 (Orderwire)

The WIS standard does not support the E2 octet and recommends transmitting 0x00 in place of the E2 octet. A value other than 0x00 can be transmitted by programming the intended value at TX\_E1 (2xE620).

## 3.5.4 Pointer

The H1 and H2 octets are used as a pointer within the SONET/SDH frame to locate the beginning of the path overhead and the beginning of the synchronous payload envelope (SPE). Within SONET/SDH the SPE can begin anywhere within the payload area, however IEEE Standard 802.3ae specifies that a transmitted SPE must always be positioned solely within a single SONET/SDH frame. The constant pointer value of 522 decimal (0x20A) must be contained in the first channel's H1 and H2 octets. Together these conditions result in the H1 and H2 octets being 0x62 and 0x0A, respectively. These are the default values of TX\_H1 (2xE615.7:0) and TX\_H2 (2xE616.15:8). Programming these registers with alternate values does not alter the positioning of the SPE, but it might induce a loss of pointer (LOP-P) at the far end, or at least prevent the far end from extracting the proper payload. Furthermore, the WIS standard specifies the frame structure be a concatenated payload. For this reason, the H1 and H2 octets in channels 2 through 192 contain the concatenation indicator.

The VSC8486-04 supports forcing the loss of pointer (LOP-P) and path alarm indication signal (AIS-P) state.

The WIS standard specifies that a 0x00 be transmitted in the H3 octet. An alternate value can be transmitted by programming TX\_H3 (2xE616.7:0).

The WIS specification does not limit the pointer position within the receive SONET/SDH frame to allow interoperability to other SONET/SDH equipment. In addition to supporting the required SONET pointer rules, the VSC8486-04 pointer interpreter optionally supports SDH pointers. This is selectable using the SDH\_RX\_MODE (2xEC40.11) bit. The differences between SONET and SDH modes are as follows:

- For SONET, the SS bits are not used and are ignored by the VSC8486-04 pointer interpreter. For SDH, these bits are set to 10 and are checked by the VSC8486-04 pointer interpreter to determine the pointer type.
- For SONET, all 192 bytes of H1 and H2 are checked by the pointer interpreter to determine the pointer type. For SDH, only the first 64 bytes (first AU-4 of an AU-4-64c) are checked.
- SONET and SDH have different increment/decrement rules. SONET uses '8 out of 10' GR-253-core objective rule, while SDH uses a majority detect rule.

The H1 and H2 octets combine to form a word with several fields as shown in [Figure 32](#), page 45.

### 3.5.4.1 Bit Designations Within Payload Pointer

The 'N' bits [15:12] carry a New Data Flag (NDF). This mechanism allows an arbitrary change in the location of the payload. NDF is indicated by at least three out of the four N bits matching the code '1001' (NDF enabled). Normal operation is indicated by three out of the four N bits matching the code '0110' (normal NDF).

The last ten bits of the pointer word ('D' bits and 'I' bits) carry the pointer value. The pointer value has a range from 0 to 782 that indicates the offset between the first byte after the H3 byte and the first byte of the SPE.

The SS bits are located in bits 11 and 10 and are unused in SONET mode. In SDH mode, these bits are compared with pattern '10', and the pointer is considered invalid if it does not match.

Because VSC8486-04 only supports concatenated frames, only the first pair of bytes (H1, H2) are called the primary pointer and have a normal format. The rest of the H1/H2 bytes contain the concatenation indication (CI). The format for the CI is NDF enabled with a pointer value of all ones.

**Figure 32 • 16-bit Designations within Payload Pointer**

H1								H2							
15	14	13	12	11	10	9	8	7	6	5	4	3	2	1	0
N	N	N	N	S	S	I	D	I	D	I	D	I	D	I	D

### 3.5.4.2 Pointer Types

The VSC8486-04 supports five different pointer types as described in the following table. A Normal Pointer indicates the current pointer, a New Data Flag indicates a new pointer location, and an AIS pointer indicates AIS. The Pointer Increment and Pointer Decrement mechanism adjusts the frequency offset between the frame overhead and SPE. A Pointer Increment is indicated by a Normal NDF that has the currently accepted pointer with the 'D' bits inverted. A Pointer Decrement is indicated by a Normal NDF that has the currently accepted pointer with 'I' bits inverted.

**Table 24 • H1/H2 Pointer Types**

Pointer Type	<i>nnnn</i> Value	Pointer Value	SS bits
Normal	Three out of the four bits matching '0110'	0 to 782	Matching in SDH mode, ignored in SONET mode
New Data Flag (NDF)	Three out of the four bits matching '1001'	0 to 782	Matching in SDH mode, ignored in SONET mode
AIS Pointer	1111	1111 1111 11	11
Pointer Increment	Three out of the four bits matching '0110'	Current pointer with 'I' bits inverted.	Matching in SDH mode, ignored in SONET mode
Pointer Decrement	Three out of the four bits matching '0110'	Current pointer with 'D' bits inverted.	Matching in SDH mode, ignored in SONET mode

**Table 25 • Concatenation Indication Types**

Pointer Type	<i>nnnn</i> Value	Pointer Value	SS bits
Normal concatenation indication	Three out of the four bits matching '1001'	1111 1111 11	Matching in SDH mode, ignored in SONET mode
AIS concatenation indication	Pointer value, <i>nnnn</i> value, and SS bits are the same as the AIS pointer indication		
Invalid concatenation indication	Any other concatenation indication other than Normal CI or AIS CI indication		

### 3.5.4.3 Pointer Adjustment Rule

The VSC8486-04 pointer interpreter adjusts the current pointer value according to rules listed in Section 9.1.6 of ANSI T1.105-1995. In addition, the following rule is observed: no increment/decrement is accepted for at least three frames following an increment/decrement or NDF operation.

### 3.5.4.4 Pointer Increment/Decrement Majority Rules

In SONET mode, the pointer interpreter uses more restrictive GR-253-CORE objective rules, as follows:

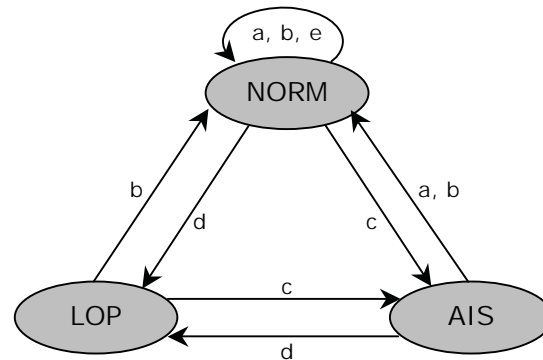
- An increment is indicated by eight or more bits matching non-inverted D bits and inverted I bits.
- A decrement is indicated by eight or more bits matching non-inverted I bits and inverted D bits.

In SDH mode, the majority rules are:

- An increment is indicated by three or more inverted I bits and two or fewer inverted D bits.
- A decrement is indicated by three or more inverted D bits and two or fewer inverted I bits.
- If both, three or more D bits are inverted and three or more I bits are inverted, no action is taken.

### 3.5.4.5 Pointer Interpretation States

The pointer interpreter algorithm for state transitions can be modeled as a finite state machine with three states, as shown in the following illustration. The three states are Normal (NORM), Loss of pointer (LOP), and Alarm Indication State (AIS).

**Figure 33 • Pointer Interpreter State Diagram**

The conditions for transitions between these states are summarized in the following table.

**Table 26 • Pointer Interpreter State Diagram Transitions**

Transitions	States	Description	Required Persistence
a	NORM → NORM AIS → NORM	<H1><H2>=<EEEESSPP><PPPPPPPP>. NDF enabled with pointer in range (0 to 782). SS bit match (if enabled).	1 frame
b	NORM → NORM LOP → NORM AIS → NORM	<H1><H2>=<DDDDSSPP><PPPPPPPP>. NDF disabled (NORM pointer) with the same pointer value in range (0 to 782). SS bit match (if enabled).	3 frames
c	NORM → AIS LOP → AIS	<H1><H2>=<11111111><11111111>. AIS pointer (0xFFFF).	3 frames
d	NORM → LOP AIS → LOP	Anything other than transitions b and c or NDF enabled (transition a) or AIS pointer when not in AIS state or NORM pointer when not in NORM state or NORM pointer with pointer value not equal to current or increment/decrement or CONC pointer or SS bit mismatch (if comparison is enabled).	8 frames
e	Justification	Valid increment or decrement indication.	1 frame

### 3.5.4.6 Valid Pointer Definition for Interpreter State Diagram Transitions

During an AIS state, only an AIS pointer is a valid pointer. In NORM state, several definitions of “valid pointer” for purpose of LOP detection are possible according to GR-253-CORE. The VSC8486-04 follows the GR-253-CORE intended definition, but adds a single normal pointer that exactly matches the current 'valid' pointer value.

Any change in the AIS state is reflected in the alarm bit AISP (2×0021.1). This latch-high register reports both the event and status information in consecutive reads. The AISP\_PEND (2×EF00.1) bit remains asserted until read. This event can propagate an interrupt to either WIS\_INTA or WIS\_INTB, based on mask enable bits AISP\_MASKA (2×EF01.1) and AISP\_MASKB (2×EF02.1).

Similarly, any change in the LOP state is reflected in the alarm bit LOPP (2×0021.0). This latch-high register reports both the event and status information in consecutive reads. The LOPP\_PEND (2×EF00.0) bit remains asserted until read. This event can propagate an interrupt to either WIS\_INTA or WIS\_INTB, based upon the mask enable bits LOPP\_MASKA (2×EF01.1) and LOPP\_MASKB (2×EF02.1).

### 3.5.5 Path Overhead

The path overhead portion of the SONET/SDH frame supports an end-to-end trace identifier, a payload parity check, a payload type indicator, a status indicator, and a user channel. The following table lists each of the octets, including their function.

**Note:** Extended WIS TOSI and ROSI do not support path overhead.

**Table 27 • STS Path Overhead Octets**

Overhead Octet	Function	IEEE 802.3ae WIS Usage	Recommended Value	WIS Extension
J1	Path trace message	Specified value	See the following discussion of J1 (overhead octet)	A 1-, 16-, or 64-byte trace message can be sent using registers (2×0027-2×002E, 2×E700, 2×EA00-2×EA17) and received using registers (2×002F-2×0036, 2×EC20, 2×EB00-2×EB17).
B3	Path error monitoring (path BIP-8)	Supported	Bit interleaved parity - 8 bits, as specified in T1.416	Both SONET and SDH mode B3 calculation is supported.
C2	Path signal label	Specified value	0×1A	Register (2×E615). Supports persistency and mismatch detection (2×EC40).
G1	Path status	Supported	As specified in T1.416	Ability to select between RDI-P and ERDI-P formats.
F2	Path user channel	Unsupported	0×00	Register (2×E618).
H4	Multiframe indicator	Unsupported	0×00	Register (2×E61A).
Z3-Z4	Reserved for path growth	Unsupported	0×00	Register (2×E61C, 2×E61E).
N1	Tandem connection maintenance and path data channel	Unsupported	0×00	Register (2×E621).

#### 3.5.5.1 J1 (Overhead Octet)

By default, the J1 transmitted octet contains a 16-octet repeating path trace message whose contents are defined in J1\_TXMSG (2×0027-2×002E). If no active message is being broadcast, a default path trace message is transmitted, consisting of 15 octets of zeros and a header octet formatted according to Section 5 of ANSI T1.269-2000. The header octet for the 15-octets of zero would be 0×89. The default values of J1\_TXMSG (2×0027-2×002E) do not contain the 0×89 value of the header octet, thus software must write this value.

The J1 octet in the receive direction by default is assumed to be carrying a 16-octet continuously repeating path trace message. The message is extracted from the incoming WIS frames and presented in J1\_RXMSG (2×002F-2×0036). The WIS receive process does not delineate the message boundaries, thus the message might appear rotated between new frame alignment events.

The VSC8486-04 supports two alternate message types, a single repeating octet and a 64-octet message. The message type can be independently selected for the transmit and receive direction. The transmit direction is configured using J1\_TXLEN (2×E700.1:0) while J1\_RXLEN (2×EC20.1:0) configures the receive path.

When the transmit direction is configured for a 64-octet message, the first 16 octets are programmed in J1\_TXMSG (2×0027-2×002E) while the 48 remaining octets are programmed in J1\_TXMSG64 (2×EA00-2×EA17). Likewise, the first 16-octets of the receive message are stored in J1\_RXMSG (2×002F-2×0036), while the other 48 octets are stored in J1\_RXMSG64 (2×EB00-2×EB17). The receive message is updated every 125 μs with the recently received octet. Any persistence or message matching is expected to take place within the station manager.

### 3.5.5.2 B3 (STS Path Error Monitoring)

The B3 octet is a bit interleaved parity-8 (BIP-8) code, using even parity, calculated over the previous STS-192c SPE before scrambling. The computed BIP-8 is placed in the B3 byte of the following frame before scrambling.

In the receive direction, the incoming frame is processed and a B3 octet is calculated over the received frame. The calculated value is then compared with the B3 value received in the following frame. The difference between the calculated and received octets are accumulated in block (maximum increment of 1 per errored frame) fashion into a B3 error register, B3\_CNT (2×003B). This counter is non-saturating and so rolls over. The counter is cleared upon a device reset.

An additional 32-bit B3 error counter is provided at B3\_ERR\_CNT (2×ECB4-2×ECB5) which is a saturating counter and is latched and cleared based upon a PMTICK event. Errors are accumulated starting from the previous PMTICK event. When the counter is nonzero, the B3\_NZ\_PEND (2×EF04.5) event is asserted until read. A non-latch high version of this event B3\_NZ\_STAT (2×EF03.5) is also available. This event can propagate an interrupt to either WIS\_INTA or WIS\_INTB, based on the mask enable bits B3\_ERR\_MASKA (2×EF05.5) and B3\_ERR\_MASKB (2×EF06.5).

The B3\_ERR\_CNT can optionally be configured to increment on a block count basis, a maximum increment of 1 per errored frame regardless of the number of errors received. The B3\_BLK (2×EC61.9) control bit, if asserted, places the B3\_ERR\_CNT counter in block increment mode.

It is possible that two sets of B3 bytes (from two SONET/SDH frames) are received by the Rx WIS logic in a period of time when only one G1 octet is transmitted. In this situation, one of the two B3 error counts delivered to the Tx WIS logic is discarded. This situation occurs when the receive data rate is faster than the transmit data rate. Similarly, when the transmit data rate is faster than the receive data rate, a B3 error count is not available for REI-P insertion into the G1 octets of the transmitted SONET/SDH frame. A value of zero is transmitted in this case. This behavior is achieved by using a FIFO to transfer the detected B3 error count from the receive to transmit domains.

A FIFO overflow or underflow condition is not considered an error. Instead it is recovered from gracefully as described above. A FIFO overflow or underflow eventually occurs, unless the transmit and receive interfaces are running at the same average data rate. Because the received and transmitted frames can differ by, at most, 40 ppm (±20 ppm) and still meet the industry standards, this “slip” can happen no more often than once every 3.1 seconds.

### 3.5.5.3 C2 (STS Path Signal Label and Path Label Mismatch)

The C2 octet contains a value intended to describe the type of payload carried within the SONET/SDH frame. The WIS standard calls for a 0×1A to be transmitted. This is the default value of TX\_C2 (2×EC15).

As specified in T1.416, a path label mismatch (PLM-P) (2×0021.2) event occurs when the C2 octet in five consecutive frames contain a value other than the expected one. The expected value is set in C2\_EXP (2×EC40.7:0), whose default value 0×1A is compliant with the WIS standard.

Whenever a value of 0×00 is accepted (received for five or more consecutive frames) the unequipped path pending, UNEQ\_PEND (2×EF04.10), event is asserted until read. A non-latch high version of this

event UNEQ\_STAT (2×EF03.10) is also available. This event can propagate an interrupt to either WIS\_INTA or WIS\_INTB, based on the mask enable bits UNEQ\_MASKA (2×EF05.10) and UNEQ\_MASKB (2×EF06.10).

If the accepted value is not an unequipped label (0×00) and it differs from the programmed expected value, C2\_EXP, then a path label mismatch, PLMP (2×0021.2), is asserted. Similarly the PLM\_PEND (2×EF00.2) event is asserted until read. This event can propagate an interrupt to either WIS\_INTA or WIS\_INTB, based on the mask enable bits PLM\_MASKA (2×EF01.2) and PLM\_MASKB (2×EF02.2).

Although PLM-P is not a path level defect, it does cause a change in the setting of one of the ERDI-P codes, as described in Table 28, page 51.

### 3.5.5.4 G1 (Remote Path Error Indication)

The most significant four bits of the G1 octet is used for back reporting the number of B3 block errors received at the near end. This is typically known as path remote error indication (REI-P). The value in this octet comes from the B3 error FIFO, as discussed with the B3 octet. The WIS standard defines a 16-bit REI-P counter REIP\_CNT (2×0025). The WIS standard defines this counter to operate as a block counter as opposed to an individual errored bit counter. This counter is non-saturating and so rolls over after its maximum count. The counter does not clear upon a read, but instead only upon reset as defined in the WIS specification. When the counter is nonzero, the REIP\_WISNZ\_PEND (2×EF04.3) event is asserted until read. A non-latch high version of this event REIP\_WISNZ\_STAT (2×EF03.3) is also available. This event can propagate an interrupt to either WIS\_INTA or WIS\_INTB, based on the mask enable bits REIP\_WISNZ\_MASKA (2×EF05.3) and REIP\_WISNZ\_MASKB (2×EF06.3), respectively.

An additional 32-bit REI-P counter is provided at REIP\_ERR\_CNT (2×EC80-2×EC81) which is a saturating counter and is latched and cleared based upon a PMTICK event. Errors are accumulated since the previous PMTICK event. When the counter is nonzero, the REIP\_EWISNZ\_PEND (2×EF04.1) event is asserted until read. A non-latch high version of this event REIP\_EWISNZ\_STAT (2×EF03.1) is also available. This event can propagate an interrupt to either WIS\_INTA or WIS\_INTB, based on the mask enable bits REIP\_EWISNZ\_MASKA (2×EF05.1) and REIP\_EWISNZ\_MASKB (2×EF06.1), respectively.

The REIP\_ERR\_CNT can optionally be configured to increment on a block count basis, a maximum increment of 1 per errored frame regardless of the number of errors received. This mode is enabled by asserting REIP\_BLK (2×EC61.5).

### 3.5.5.5 G1 (Path Status)

In addition to back-reporting the far end B3 BIP-8 error count, the G1 octet carries status information from the far end device known as path remote defect indicator (RDI-P). T1.416 allows either support of 1-bit RDI-P or 3-bit ERDI-P, but indicates ERDI-P is preferred. VSC8486-04 supports both modes and can be independently configured for the Rx and Tx directions by configuring RX\_G1\_MODE (2×EC40.8) and TX\_G1\_MODE (2×E600.10). ERDI-P is the default for both directions.

The different structures for this octet are shown in the following illustrations.

**Figure 34 • Path Status (G1) Byte for ERDI\_RDIN = 0**

G1 REI (B3)				RDI-P	Reserved		Spare
1	2	3	4	5	6	7	8
Remote Error Indicator count from B3 (0-8 value)				Remote Defect Indicator	Set to 00 by transmitter		Ignored by receiver

**Figure 35 • Path Status (G1) Byte for ERDI\_RDIN = 1**

G1 REI (B3)				ERDI-P			Spare
1	2	3	4	5	6	7	8
Remote Error Indicator count from B3 (0-8 value)				Enhanced Remote Defect Indicator (see following table)			Ignored by receiver

Enhanced RDI is defined for SONET-based systems as listed in GR-253-CORE (Issue 3), reproduced here in the following table, and as a possible enhancement of SDH-based systems (G.707/Y.1322 (10/2000) Appendix VII (not an integral part of that recommendation)).

**Table 28 • RDI-P and ERDI-P Bit Settings and Interpretation**

G1 Bits 5, 6, and 7	Priority of ERDI-P Codes	Trigger	Interpretation
000/011	Not applicable	No defects.	No RDI-P defect
100/111	Not applicable	Path alarm indication signal (AIS-P). The remote device sends all ones for H1, H2, H3, and the entire STS SPE. Path loss of pointer (LOP-P).	One-bit RDI-P defect
001	4	No defects.	No ERDI-P defect
010	3	Path label mismatch (PLM-P). Path loss of code group delineation (LCD-P).	ERDI-P payload defect
101	1	Path alarm indication signal (AIS-P). The remote device sends all ones for H1, H2, H3 and entire STS SPE. Path loss of pointer (LOP-P).	ERDI-P server defect
110	2	Path unequipped (UNEQ-P). The received C2 byte is 0×00. Path trace identifier mismatch (TIM-P). This error is not automatically generated, but can be forced using MDIO.	ERDI-P connectivity defect

In the receive direction, with RX\_G1\_MODE (2×EC40.8) = 0, an RDI-P defect is the occurrence of the RDI-P signal in 10 contiguous frames. An RDI-P defect terminates when no RDI-P signal is detected in 10 contiguous frames. An RDI-P event asserts FERDIP\_PEND (2×EF04.8) until read. A non-latch high version of the far-end RDI-P status can be found in FERDIP\_STAT (2×EF03.8). This event can propagate an interrupt to either WIS\_INTA or WIS\_INTB, based on the mask enable bits FERDIP\_MASKA (2×EF05.8) and FERDIP\_MASKB (2×EF06.8).

When RX\_G1\_MODE (2×EC40.8) = 1, an ERDI-P defect is the occurrence of any one of three ERDI-P signals in 10 contiguous frames. An ERDI-P defect terminates when no ERDI-P signal is detected in 10 contiguous frames.

The “010” code triggers the latch high register bit FE\_PLM-P\_LCD-P (2×0021.10). It also asserts FE\_PLM-P\_LCD-P\_PEND (2×EF00.10) until read. This event can propagate an interrupt to either WIS\_INTA or WIS\_INTB, based on the mask enable bits FE\_PLM-P\_LCD-P\_MASKA (2×EF01.10) and FE\_PLM-P\_LCD-P\_MASKB (2×EF02.10), respectively.

The “101” code triggers the latch high register bit FE\_AIS-P\_LOP-P (2×0021.9). It also asserts FE\_AIS-P\_LOP-P\_PEND (2×EF00.9) until read. This event can propagate an interrupt to either WIS\_INTA or WIS\_INTB, based on the mask enable bits FE\_AIS-P\_LOP-P\_MASKA (2×EF01.9) and FE\_AIS-P\_LOP-P\_MASKB (2×EF02.9), respectively.

The “110” code asserts the FE\_UNEQ-P\_PEND (2×EF04.9) until read. A non-latch-high version of this register FE\_UNEQ\_STAT (2×EF03.9) is also available. This event can propagate an interrupt to either WIS\_INTA or WIS\_INTB, based on the mask enable bits FE\_UNEQ-P\_MASKA (2×EF05.9) and FE\_UNEQ-P\_MASKB (2×EF06.9), respectively.



### 3.5.5.6 F2 (Path User Channel)

The WIS standard does not support the F2 octet and recommends transmitting 0x00 in place of the F2 octet. A value other than 0x00 can be transmitted by programming the intended value at TX\_F2 (2xE618).

### 3.5.5.7 H4 (Multi-frame Indicator)

The WIS standard does not support the H4 multi-frame octet and recommends transmitting 0x00 in place of the H4 octet. A value other than 0x00 can be transmitted by programming the intended value at TX\_H4 (2xE61A).

### 3.5.5.8 Z3-Z4 (Reserved for Path Growth)

The WIS standard does not support the Z3-Z4 octets and recommends transmitting 0x00 in their place. A value other than 0x00 can be transmitted by programming the intended value at TX\_Z3 (2xE61C) and TX\_Z4 (2xE61E) respectively.

### 3.5.5.9 N1 (Tandem Connection Maintenance/Path Data Channel)

The WIS standard does not support the N1 octet and recommends transmitting 0x00 in place of the N1 octet. A value other than 0x00 can be transmitted by programming the intended value at TX\_N1 (2xE621).

### 3.5.5.10 Loss of Code group Delineation

After the overhead is stripped, the payload is passed to the PCS. If the PCS block loses synchronization and cannot delineate valid code groups, the PCS passes a loss of code group delineation (LCD-P) alarm to the WIS. This alarm triggers the latch high register bit LCD-P (2x0021.3). It also asserts LCD-P\_PEND (2xEF00.3) until read. This event can propagate an interrupt to either WIS\_INTA or WIS\_INTB, based on the mask enable bits LCD-P\_MASKA (2xEF01.3) and LCD-P\_MASKB (2xEF02.3), respectively.

The WIS specification calls for a LCD-P defect persisting continuously for more than 3 ms to be back reported to the far end. Upon device reset a LCD-P shall also be back reported until the PCS signals that valid code groups are being delineated. The LCD-P defect deasserts (and is not back reported) after the condition is absent continuously for at least 1 ms.

## 3.5.6 Reading Statistical Counters

The VSC8486-04 contains several counters that can be read using the MDIO interface. For each error count, there are two sets of counters. The first set is the standard WIS counter implemented according to IEEE Standard 802.3ae, and the second set is for statistical counts using PMTICK.

To read the IEEE Standard 802.3ae counters, the Station Manager must read the most significant register of the 32-bit counter first. This read action latches the internal error counter value into the MDIO readable registers. A subsequent read of the least significant register does not latch new values, but returns the value latched at the time of the most significant register read.

Since the IEEE Standard 802.3ae counters are independently latched it can be difficult to get a clear picture of the timeframes in which errors were received. The PMTICK counters are all latched together, thereby providing a complete snapshot in time. When PMTICK is asserted the internal error counter values are copied into their associated registers and the internal counters are reset.

There are three methods of asserting PMTICK.

- The Station Manager can asynchronously assert PMTICK\_FRC (2xEC60.0) to latch the values at a given time, regardless of the PMTICK\_ENA (2xEC60.2) setting.
- The VSC8486-04 can be configured to latch and clear the statistical counters at a periodic interval as determined by the timer (count) value in PMTICK\_DUR (2xEC60.15:3). In this mode the PMTICK\_SRC (2xEC60.1) must be configured for internal mode and the PMTICK\_ENA (2xEC60.2) bit must be asserted. The receive path clock is used to drive the PMTICK counter, thus the periodicity of the timer can vary during times of loss of lock and loss of frame.
- The VSC8486-04 can be configured to latch and clear the statistical counters at the occurrence of a rising edge detected at the PMTICK input pin. In this mode the PMTICK\_SOURCE (2xEC60.1) bit must be deasserted, and the PMTICK\_ENA (2xEC60.2) must be asserted.

Regardless of PMTICK\_SRC (2×EC60.1), when the PMTICK event occurs the PMTICK\_PEND (2×EF04.14) is asserted until read. This event can propagate an interrupt to either WIS\_INTA or WIS\_INTB, based on the mask enable bits PMTICK\_MASKA (2×EF05.14) and PMTICK\_MASKB (2×EF06.14), respectively.

Given the size of the error counters and the maximum allowable error counts per frame, care must be taken in the frequency of polling the registers to ensure accurate values. All PMTICK counters saturate at their maximum values.

**Table 29 • PMTICK Counters**

Counter Name	Description	Registers	Maximum Increase Count Per Frame	Maximum Increase Count Per Second	Time Until Overflow
B1_ERROR_CNT	B1 section error count	B1_ERROR_CNT1, B1_ERROR_CNT0	8	64,000	67,109
B2_ERROR_CNT	B2 line error count	B2_ERROR_CNT1, B2_ERROR_CNT0	1536	12,288,000	350
B3_ERROR_CNT	B3 path error count	B3_ERROR_CNT1, B3_ERROR_CNT0	8	64,000	67,109
FAR_B3_ERROR_CNT	Far end B3 path error count	FAR_B3_ERROR_CNT1, FAR_B3_ERROR_CNT0	8	64,000	67,109
FAR_B2_ERROR_CNT	Far end B2 line error count	FAR_B2_ERROR_CNT1, FAR_B2_ERROR_CNT0	1536	12,288,000	350

Both individual and block mode accumulation of B1, B2, and B3 error indications are supported and selectable using the control bits B1\_BLK, B2\_BLK, and B3\_BLK. In individual accumulation mode, '0', the counter is incremented for each bit mismatch between the calculated B1, B2, and/or B3 error and the extracted B1, B2, and/or B3. In block accumulation mode, '1', the counter is incremented only once for any nonzero number of bit mismatches between the calculated B1, B2, and/or B3 and the extracted B1, B2, and/or B3 (maximum of 1 error per frame).

### 3.5.7 Defects and Anomalies

All defects and anomalies listed in the following table can be forced and masked by the user. The VSC8486-04 does not automatically generate TIM-P, but does support forcing defects using MDIO.

**Table 30 • Defects and Anomalies**

Defect or Anomaly	Description	Type	Force Bit	Status Bit
Far end PLM-P or LCD-P	These two errors are indistinguishable when reported by the far end through the G1 octet (ERDI-P), because the far end reports both PLM-P and LCD-P with the same error code.	Far end defect	2×EC31.10	2×0021.10
Far end AIS-P or LOP-P	These two errors are indistinguishable when reported by the far end through the G1 octet (ERDI-P), because the far end reports both AIS-P and LOP-P with the same error code.	Far end defect	2×EC31.12	2×0021.9

**Table 30 • Defects and Anomalies (continued)**

Defect or Anomaly	Description	Type	Force Bit	Status Bit
PLM-P	Path label mismatch. The detection and reporting of the PLM-P defect follows section 7.5 of ANSI T1.416-1999.	Near end defect; propagated to PCS	2×EC31.14	2×0021.2
AIS-L	Generated on LOPC, LOS, LOF, if enabled by AISL_ON_LOPC (2×EE00.6), AISL_ON_LOS (2×EE00.5), AISL_ON_LOF (2×EE00.4), or when forced by user.	Near end defect	The AIS-L defect is only processed and reported by the WIS Receive process; it is never transmitted by the WIS Transmit process according to IEEE 802.3ae.	2×EC30.3/2 ×0021.4
AIS-P	Path alarm indication signal.	Near end defect; propagated to PCS	2×EC30.1	2×0021.1
LOP-P	Path loss of pointer. Nine consecutive invalid pointers result in loss of pointer detection. See <a href="#">Figure 33</a> , page 47 for pointer state machine.	Near end defect; propagated to PCS	2×EC30.0	2×0021.0
LCD-P	Path loss of code group delineation. See <a href="#">Table 28</a> , page 51. This is also reported to the far end if it persists for at least 3 ms.	Near end defect	2×EC31.2	2×0021.3
LOPC	Loss of optical carrier alarm. This is an input from the XFP module's loss of signal output. The polarity can be inverted for use with other module types. This defect can be used independently or in place of LOS.	Near end defect	2×EC30.12	2×EF03.11
LOS	The PMA circuitry detects a Loss Of Signal (LOS) defect if the input signal falls below the assert threshold. Refer the PMA LOS section for more details. When a PMA LOS is declared the framer is held in reset to prevent it from looking for a frame boundary.	Near end defect	2×EC30.11	2×0021.6
SEF	Severely errored frame. Generated when device cannot frame to A1 A2 pattern. SEF indicates synchronization process is not in the SYNC state, as defined by the state diagram of IEEE 802.3ae clause 50.4.2.	Near end defect; propagated to PCS	2×EC31.7	2×0021.11
LOF	Generated when SEF persists for 3 ms. Terminated when no SEF occurs for 1 ms to 3 ms.	Near end defect	2×EC31.6	2×0021.7

**Table 30 • Defects and Anomalies (continued)**

Defect or Anomaly	Description	Type	Force Bit	Status Bit
B1 PMTICK error count is nonzero	BIP-N(S) - 32-bit near end section BIP error counter is nonzero.	Near end anomaly	2×EC31.5	2×EF03.7
B2 PMTICK error count is nonzero	BIP-N(L) - 32-bit near end line BIP error counter is nonzero.	Near end anomaly	2×EC31.4	2×EF03.6
B3 PMTICK error count is nonzero	BIP-N(P) - 32-bit near end path BIP error counter is nonzero.	Near end anomaly	2×EC31.3	2×EF03.5
REI-L	Line remote error indicator octet is nonzero. Far end BIP-N(L).	Far end anomaly	2×EC31.8	2×EF03.4
REI-L PMTICK error count is nonzero	Line remote error indicator is nonzero. Far end BIP-N(L).	Far end anomaly	2×EC31.1	2×EF03.2
RDI-L	Line remote defect indicator.	Far end defect	2×EC30.2	2×0021.5
REI-P	Path remote error indicator octet is nonzero. Far end BIP-N(P).	Far end anomaly	2×EC31.9	2×EF03.3
REI-P PMTICK error count is nonzero	Path remote error indicator. Far end BIP-N(P).	Far end anomaly	2×EC31.0	2×EF03.1
UNEQ-P	Unequipped path.	Near end defect	2×EC31.15	2×EF03.10
Far end UNEQ-P	Far end unequipped path.	Far end defect	2×EC31.11	2×EF03.9

### 3.5.8 Interrupt and Interrupt Masking

The VSC8486-04 generates interrupts for each defect and anomaly. The interrupts for the BIP error counts (B1, B2, and B3 counters) and the interrupts for the far end error counts (REI-L and REI-P) are generated when the PMTICK counters become nonzero. Mask enable bits propagate the interrupt pending event to the pins WIS\_INTA and WIS\_INTB. Each event can be optionally masked for each WIS\_INTA/B pin.

For each defect or anomaly defined in IEEE Standard 802.3ae, the VSC8486-04 supports the standard WIS register. In addition the VSC8486-04 supports another set of registers in the WIS Vendor Specific area. These registers provide a STATUS bit to indicate the current real-time status of the event, a PENDING bit to indicate if the STATUS bit has changed state, and two mask enable bits for each interrupt pin (WIS\_INTA and WIS\_INTB). The STATUS bit is set if and only if the interrupt currently exists. This STATUS bit does not latch.

The defects and anomalies are constructed in a hierarchy such that lower order alarms are squelched when higher order events are detected. For more information about the dependencies between squelches and events, see the E-WIS interrupt registers, beginning with [Table 169](#), page 142 and [Table 100](#), page 119.

### 3.5.9 Overhead Serial Interfaces

The VSC8486-04 includes provisions for off-chip processing of the critical SONET/SDH transport overhead 9-bit words through two independent serial interfaces. The transmit overhead serial interface

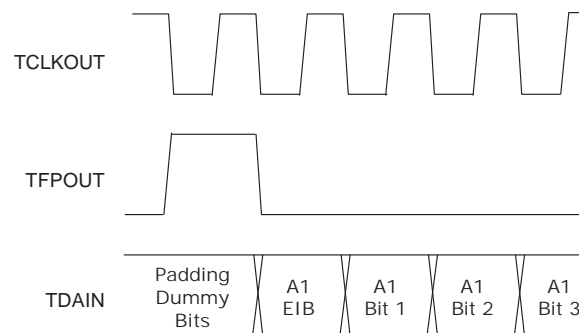
(TOSI) is used to insert 9-bit words into the transmit frames, and the receive overhead serial interface (ROSI) is used to recover the 9-bit words from the received frames. The interfaces each consists of three pins: a clock output, a frame pulse output, and a data input (Tx) /output (Rx). These I/O are LVTTTL compatible for easy connection to an external device such as an FPGA.

**Note:** Extended WIS TOSI and ROSI do not support path overhead.

### 3.5.9.1 Transmit Overhead Serial Interface (TOSI)

The TOSI port enables the user to individually program 222 separate 9-bit words in the SONET/SDH overhead. The SONET/SDH frame rate is 8 kHz as signaled by the frame pulse (TFPOUT) signal. The TOSI port is clocked from a divided-down version of the WIS transmit clock made available on TCLKOUT. To provide a more standard clock rate, 9-bit dummy words are added per frame resulting in a clock running at one five-hundred-twelfth of the line rate or 19.44 MHz. For each 9-bit word, the external device indicates the desire to transmit that byte by using an enable indicator bit (EIB) that is appended to the beginning of the 9-bit word. If EIB = 0, the data on the serial interface is ignored for that overhead 9-bit word. If EIB = 1, the serial interface data takes precedence over the value generated within the VSC8486-04. The first EIB bit should be transmitted by the external device on the first rising edge of TCLKOUT after TFPOUT, as illustrated in the following illustration. The data should be provided with the most significant bit (MSB) first. After reception of the TOSI data for a complete frame, the values are placed in the overhead for the next transmitted frame.

**Figure 36 • TOSI Timing Diagram**



Some 9-bit words are error masks, such that the transmitted 9-bit word is the XOR of the TOSI 9-bit word and the pre-defined value within the chip if the EIB is enabled. This feature is best used for test purposes only.

The order of the 9-bit word required by the TOSI port is summarized in the following table, where the number of registers is the number of bytes on the serial interface and the number of bytes is the number of STS channels on which the byte is transmitted. For H1 and H2 pointers, bytes 2 to 192 are concatenation indication bytes consistent with STS-192c frames. There are not 192 different point locations as in STS-192 frames.

**Table 31 • TOSI/ROSI Addresses**

Byte Name	9-Bit Word	TOSI/ROSI Byte Order	Number of Registers	Number of Bytes	Type
Frame Boundary	A1	0	1	192	Programmable byte that is identical for all locations
Frame Boundary	A2	1	1	192	Programmable byte that is identical for all locations
Section Trace	J0	2	1	1	Programmable byte
Section Growth	Z0	3	1	191	Programmable byte that is identical for all locations

**Table 31 • TOSI/ROSI Addresses (continued)**

Byte Name	9-Bit Word	TOSI/ROSI Byte Order	Number of Registers	Number of Bytes	Type
Dummy Byte		4	1	1	Programmable byte
Section BIP-8	B1	5	1	1	TOSI inserts error mask; ROSI extracts XOR of B1 value and received data
Orderwire	E1	6	1	1	Programmable byte
Section User Channel	F1	7	1	1	Programmable byte
Dummy Byte		8	1	1	Programmable bytes
Section DCC 1	D1	9	1	1	Programmable byte
Section DCC 2	D2	10	1	1	Programmable byte
Section DCC 3	D3	11	1	1	Programmable byte
Dummy Byte		12	1	1	Programmable byte
Pointer 1	H1	13	1	1	Programmable byte affecting the first H1 byte
Pointer 2	H2	14	1	1	Programmable byte affecting the first H2 byte
Pointer Action	H3	15	1	192	Programmable byte that is identical for all locations
Dummy Byte		16	1	1	Programmable byte
Line BIP-8	B2	17 to 208	192	192	TOSI inserts error mask for each byte; ROSI extracts XOR of B2 value and received data for each byte
Automatic Protection Switching (APS) channel and Remote Defect Indicator (RDI)	K1	209	1	1	Programmable byte
Automatic Protection Switching (APS) channel and Remote Defect Indicator (RDI)	K2	210	1	1	Programmable byte
Dummy Byte		211	1	1	Programmable byte
Line DCC 4	D4	212	1	1	Programmable byte
Line DCC 5	D5	213	1	1	Programmable byte
Line DCC 6	D6	214	1	1	Programmable byte
Dummy Byte		215	1	1	Programmable byte
Line DCC 7	D7	216	1	1	Programmable byte
Line DCC 8	D8	217	1	1	Programmable byte
Line DCC 9	D9	218	1	1	Programmable byte
Dummy Byte		219	1	1	Programmable byte
Line DCC 10	D10	220	1	1	Programmable byte

**Table 31 • TOSI/ROSI Addresses (continued)**

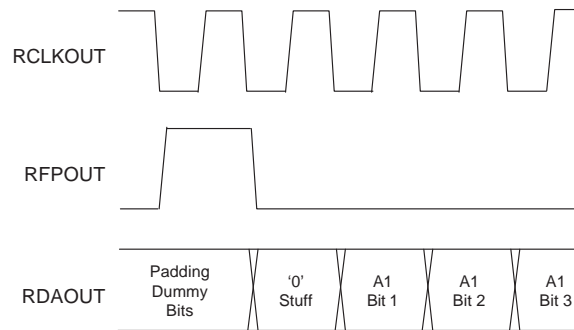
Byte Name	9-Bit Word	TOSI/ROSI Byte Order	Number of Registers	Number of Bytes	Type
Line DCC 11	D11	221	1	1	Programmable byte
Line DCC 12	D12	222	1	1	Programmable byte
Dummy Byte		223	1	1	Programmable byte
Synchronization Message	S1	224	1	1	Programmable byte
Growth 1	Z1	225	1	191	Programmable byte that is identical for all locations
Growth 2	Z2	226	1	190/191	Programmable byte that is identical for all locations; dependent upon 2×EC40.12
STS-1 REI-L	M0	227	1	1	Programmable byte
STS-N REI-L	M1	228	1	1	Programmable byte
Orderwire 2	E2	229	1	1	Programmable byte
Dummy Byte		230	1	1	Programmable byte
Padding Dummy Bytes		231 to 269	39		No function

### 3.5.9.2 Receive Overhead Serial Interface (ROSI)

The ROSI port extracts the same 222 overhead 9-bit words from the SONET/SDH frame, and consists of the clock output (RCLKOUT), frame pulse output (RFPOUT), and data output (RDAOUT). The ROSI port is clocked from a divided-down version of the WIS receive clock, and is valid during in-frame conditions only. As with the TOSI port, 9-bit dummy words are provided each frame period resulting in a 19.44 MHz RCLKOUT frequency. For each 9-bit word, including the 9-bit dummy words, an extra '0' bit is stuffed at the beginning of each byte so that the TOSI and ROSI clock rates are identical. The first stuff bit for each frame is transmitted by RDAOUT on the first rising edge of RCLKOUT after the frame pulse (RFPOUT).

Since the Receive path overhead can be split across two frames, the VSC8486-04 buffers the overhead for an additional frame time so that a complete path overhead is presented. Table 31, page 56, outlines the order for each of the 9-bit words presented on the ROSI port. With the exception of the M0/M1 9-bit words, the extracted 9-bit words are from the first channel position. In place of parity and error 9-bit words, the VSC8486-04 outputs the result of an XOR between the calculated BIP and the received value. Therefore, a count of ones within each of the BIP 9-bit words should correspond with the internal error accumulators. The following figure shows the functional timing for the ROSI interface.

The following illustration shows the functional timing of the ROSI port.

**Figure 37 • ROSI Timing Diagram**

### 3.5.10 Pattern Generator and Checker

The VSC8486-04 implements the square wave, PRBS31, and mixed-frequency test patterns as described in section 50.3.8 of IEEE Standard 802.3ae as well as the Test Signal Structure (TSS) and continuous identical digits (CID) pattern.

The square wave pattern is selected asserting `WIS_TEST_PAT_SEL` (2×0007.3) while the generator is enabled by asserting `WIS_TEST_PAT_GEN` (2×0007.1). When `WIS_TEST_PAT_SEL` (2×0007.3) is deasserted the mixed frequency test pattern is selected. The square wave frequency is configured according to `WIS_SQWV_LEN` (2×0600.7:4). The `WIS_TEST_PAT_ANA` (2×0007.2) bit is used to enable the test pattern checker in the receive path. The checker does not operate on square wave receive traffic. Error counts from the mixed frequency pattern are presented in the SONET/SDH BIP-8 counters, `B1_CNT` (2×003C), `B2_CNT` (2×0039), and `B3_CNT` (2×003B).

The VSC8486-04 supports the PRBS31 test pattern as reflected in `PRBS31_SUPPORT` (2×0008.1). The transmitter/generator is enabled by asserting `WIS_TEST_PRBS_GEN` (2×0007.4) while the receiver/checker is enabled by asserting `WIS_TEST_PRBS_ANA` (2×0007.5). As the mixed frequency/square wave test patterns have priority over the PRBS31 pattern, `TEST_PAT_GEN` (2×0007.1) must be disabled for the PRBS31 test pattern to be sent. Error counts from the PRBS31 checker are available in `WIS_TEST_PAT_CNT` (2×0009). This register does not roll over after reaching its maximum count and is cleared after every read operation. Two status bits are available from the PRBS checker. The `PRBS_NZ` (2×EC51.1) bit indicates whether the error counter is nonzero. The `PRBS_SYNC` (2×EC51.0) bit if asserted indicates that checker is synchronized and actively checking received bits. For test purposes, the PRBS generator can inject single bit errors. By asserting `PRBS_INJ_ERR` (2×EC50.1), a single bit error is injected, resulting in three bit errors being detected within the checker. The value of three comes from the specification, which indicates one error should be detected for each tap within the checker.

### 3.5.11 Protocol Implementation Conformance Statement

The device supports all mandatory options and functions given in the Protocol Implementation Conformance Statement (PICS) in section 50.6 of IEEE Standard 802.3ae. Of the “Major capabilities/options,” the device supports the optional MDIO and PRBS31 Test-pattern mode, but does not support the optional XSBI compatible interface.

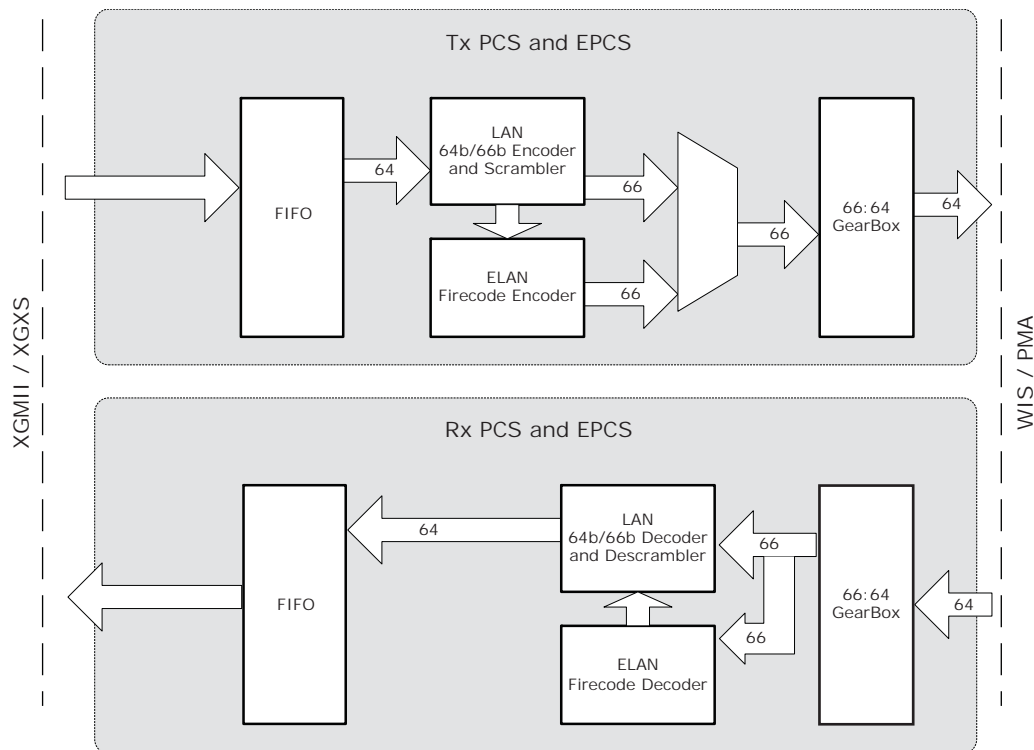
## 3.6 Physical Coding Sublayer

The physical coding sublayer (PCS) is defined in IEEE Standard 802.3ae Clause 49. The PCS is responsible for transferring data between the XGMII or XGXS clock domain and the WIS/PMA clock domain. In addition, the PCS encodes and scrambles the data for efficient transport across the given medium.

The following illustration provides a block diagram of the PCS including how it glues the XGMII/XGXS blocks to the WIS/PMA blocks and shows the alternate paths used by the E-PCS block which is discussed later.



**Figure 38 • PCS Block Diagram**



### 3.6.1 Control Codes

The VSC8486-04 supports the use of all control codes and ordered sets necessary for 10 GbE and 10 GFC operation. The following table lists the control characters, notation, and control codes.

**Table 32 • Control Codes**

Control Character	Notation <sup>1</sup>	XGMII Control Code	10-G BASE-R Control Code	10-G BASE-R O Code	8b/10b Code <sup>2</sup>
Idle	/I/	0x07	0x00		K28.0 or K28.3 or K28.5
Start	/S/	0xfb	Encoded by block type field		K27.7
Terminate	/T/	0xfd	Encoded by block type field		K29.7
Error	/E/	0xfe	0x1e		K30.7
Sequence ordered_set	/Q/	0x9c	Encoded by block type field plus O code	0x0	K28.4
Reserved 0	/R/	0x1c	0x2d		K28.0
Reserved 1		0x3c	0x33		K28.1
Reserved 2	/A/	0x7c	0x4b		K28.3
Reserved 3	/K/	0xbc	0x55		K28.5
Reserved 4		0xdc	0x66		K28.6
Reserved 5		0xf7	0x78		K23.7
Signal ordered_set <sup>3</sup>	/Fsig/	0x5c	Encoded by block type field plus O code	0xF	K28.2

1. The codes for /A/, /K/ and /R/ are used on the XAUI interface to signal idle. They are not present on the XGMII when no errors have occurred, but certain bit errors cause the PHY XS to send them on the XGMII.
2. For information only. The 8b/10b code is specified in Clause 36. Usage of the 8b/10b code for 10 Gbps operation is specified in Clause 4.
3. Reserved for INCITS T11 - 10 GFC  $\mu$ s.

### 3.6.2 Transmit Path

In the transmit direction, the PCS accepts data from the XGMII or XGXS interface, depending on PCS\_XGMII\_SRC (3×8005.8), which has its own clock domain, and transfers the data into the PMA transmit clock domain. Clock rate disparity compensation takes place in a FIFO. The overflow/underflow status bits for the FIFO can be monitored at (3×8009.1:0). Based on the FIFO's fill level, idle characters are added or removed as needed. Two counters accumulate the number of added and removed idle characters, TX\_IDLE\_ADD (3×800C) and TX\_IDLE\_DROP (3×800D). These counters can be used to gain some insight into the clock rate disparity.

Once in the PMA clock domain, the characters are checked for validity. The occurrence of invalid characters cause the PCS\_TXCHARERR\_CNT (3×8014) register to increment. Likewise the occurrence of an invalid sequence causes the PCS\_TXSEQERR\_CNT (3×8012) register to increment. Transmitted data is handled according to IEEE Standard 802.3ae Clause 49.

The characters are then processed in a two-step manner. First the 64-bits are encoded and a 2-bit header is calculated to form a single 66-bit block. The two header bits are used for block delineation and classification. The only valid header codes are '01' to indicate a payload of all data octets and '10' to indicate the presence of one or more control characters within the payload. The second step is to maintain a DC balanced signal on the serial line, thus the 64-bit encoded payload is scrambled using a self-synchronizing scrambler that implements the polynomial  $G(x) = 1 + x^{39} + x^{58}$ . The header bits are not scrambled as they are already DC balanced. For debug purposes, the scrambler can be disabled by deasserting SCR\_DIS (3×8005.9).

The 66-bit blocks are then passed to the PMA through a 66:64 gearbox. The gearbox merely feeds the 66-bit data into the WIS/PMA's 64-bit data path.

### 3.6.3 Receive Path

In the receive direction, the PCS accepts data from the WIS/PMA block and reformats it for transmission to the XGMII or XGXS interface. Because of the data path width mismatches between the WIS/PMA and the PCS, a 64:66 gearbox is needed. The gearbox also performs block synchronization/alignment based upon the 2-bit synchronization header. When the receive logic receives 64 continuous valid sync headers the BLOCK\_LOCK (3×0021.15) bit is asserted. This bit is a latch-low bit; therefore, a second read of the bit returns the current status. If 16 invalid block sync. headers are detected within a 125  $\mu$ s period, the PCS\_HIGHBER (3×0021.14) bit is asserted. This bit is a latch-high bit, and therefore a second read of the bit returns the current status.

Once block synchronization is achieved, the occurrence of errored blocks are accumulated in the PCS\_ERRORED\_BLOCKS (3×0021.7:0) counter. An errored block is one that has one or more of the following defects:

- The sync field has a value of 00 or 11.
- The block type field contains a reserved value.
- Any control character contains an incorrect value. For more information about control code values, see [Table 32](#), page 60.
- Any O code contains an incorrect value. For more information about control code values, see [Table 32](#), page 60.
- The set of eight XGMII characters does not have a corresponding block format shown in the following illustration.

Figure 39 • 64b/66b Block Formats

Input Data	Sync	Block Payload										
Bit Position:	0 1 2	65										
Data Block Format:												
D0 D1 D2 D3/D4 D5 D6 D7	01	D <sub>0</sub>	D <sub>1</sub>	D <sub>2</sub>	D <sub>3</sub>	D <sub>4</sub>	D <sub>5</sub>	D <sub>6</sub>	D <sub>7</sub>			
Control Block Formats:		Block Type Field										
C0 C1 C2 C3/C4 C5 C6 C7	10	0x1e	C <sub>0</sub>	C <sub>1</sub>	C <sub>2</sub>	C <sub>3</sub>	C <sub>4</sub>	C <sub>5</sub>	C <sub>6</sub>	C <sub>7</sub>		
C0 C1 C2 C3/O4 D5 D6 D7	10	0x2d	C <sub>0</sub>	C <sub>1</sub>	C <sub>2</sub>	C <sub>3</sub>	O <sub>4</sub>	D <sub>5</sub>	D <sub>6</sub>	D <sub>7</sub>		
C0 C1 C2 C3/S4 D5 D6 D7	10	0x33	C <sub>0</sub>	C <sub>1</sub>	C <sub>2</sub>	C <sub>3</sub>			D <sub>5</sub>	D <sub>6</sub>	D <sub>7</sub>	
O0 D1 D2 D3/S4 D5 D6 D7	10	0x66	D <sub>1</sub>	D <sub>2</sub>	D <sub>3</sub>	O <sub>0</sub>			D <sub>5</sub>	D <sub>6</sub>	D <sub>7</sub>	
O0 D1 D2 D3/O4 D5 D6 D7	10	0x55	D <sub>1</sub>	D <sub>2</sub>	D <sub>3</sub>	O <sub>0</sub>	O <sub>4</sub>	D <sub>5</sub>	D <sub>6</sub>	D <sub>7</sub>		
S0 D1 D2 D3/D4 D5 D6 D7	10	0x78	D <sub>1</sub>	D <sub>2</sub>	D <sub>3</sub>	D <sub>4</sub>		D <sub>5</sub>	D <sub>6</sub>	D <sub>7</sub>		
O0 D1 D2 D3/C4 C5 C6 C7	10	0x4b	D <sub>1</sub>	D <sub>2</sub>	D <sub>3</sub>	O <sub>0</sub>	C <sub>4</sub>	C <sub>5</sub>	C <sub>6</sub>	C <sub>7</sub>		
T0 C1 C2 C3/C4 C5 C6 C7	10	0x87			C <sub>1</sub>	C <sub>2</sub>	C <sub>3</sub>	C <sub>4</sub>	C <sub>5</sub>	C <sub>6</sub>	C <sub>7</sub>	
D0 T1 C2 C3/C4 C5 C6 C7	10	0x99	D <sub>0</sub>			C <sub>2</sub>	C <sub>3</sub>	C <sub>4</sub>	C <sub>5</sub>	C <sub>6</sub>	C <sub>7</sub>	
D0 D1 T2 C3/C4 C5 C6 C7	10	0xaa	D <sub>0</sub>	D <sub>1</sub>			C <sub>3</sub>	C <sub>4</sub>	C <sub>5</sub>	C <sub>6</sub>	C <sub>7</sub>	
D0 D1 D2 T3/C4 C5 C6 C7	10	0xb4	D <sub>0</sub>	D <sub>1</sub>	D <sub>2</sub>			C <sub>4</sub>	C <sub>5</sub>	C <sub>6</sub>	C <sub>7</sub>	
D0 D1 D2 D3/T4 C5 C6 C7	10	0xcc	D <sub>0</sub>	D <sub>1</sub>	D <sub>2</sub>	D <sub>3</sub>			C <sub>5</sub>	C <sub>6</sub>	C <sub>7</sub>	
D0 D1 D2 D3/D4 T5 C6 C7	10	0xd2	D <sub>0</sub>	D <sub>1</sub>	D <sub>2</sub>	D <sub>3</sub>	D <sub>4</sub>			C <sub>6</sub>	C <sub>7</sub>	
D0 D1 D2 D3/D4 D5 T6 C7	10	0xe1	D <sub>0</sub>	D <sub>1</sub>	D <sub>2</sub>	D <sub>3</sub>	D <sub>4</sub>	D <sub>5</sub>			C <sub>7</sub>	
D0 D1 D2 D3/D4 D5 D6 T7	10	0xff	D <sub>0</sub>	D <sub>1</sub>	D <sub>2</sub>	D <sub>3</sub>	D <sub>4</sub>	D <sub>5</sub>	D <sub>6</sub>			

Valid blocks then recover their original payload data by being descrambled. The descrambler is the same polynomial as used by the transmitter. For test purposes, the descrambler can be disabled by asserting DSCR\_DIS (3×8005.10). The data is checked for valid characters and sequencing. The occurrence of invalid characters causes the RXCHARERR\_CNT (3×8015) to increment, while the occurrence of a sequence error causes the RXSEQERR\_CNT (3×8011) to increment.

The data is passed from the PMA/WIS clock domain to the XGMII or XGXS clock domain through a FIFO. The overflow/underflow status bits for the FIFO are reflected in RX\_OFLOW (3×8009.3) and RX\_UFLOW (3×8009.2). Based upon the FIFO's fill level, idle characters are added or removed as needed. RX\_IDLE\_ADD (3×800E) and RX\_IDLE\_DROP (3×800F) accumulate the number of added and dropped idle characters at this interface.

### 3.6.4 PCS Test Modes

The PCS block offers all of the standard defined test pattern generators and analyzers. In addition the VSC8486-04 supports a 64-bit static user pattern and the optional PRBS31 pattern. Two error counters are available. Each are saturating counters and cleared upon a read operation. The first, PCS\_ERR\_CNT (3×002B), is located in the IEEE Standard area while the 32-bit, PCS\_VSERR\_CNT (3×8007-3×8008), is located in the vendor specific area.

The IEEE specification defines two test pattern modes, a square wave generator and a pseudo-random test pattern. The square wave generator is enabled by first selecting the square wave pattern by asserting PCS\_TSTPAT\_SEL (3×002A.1) then enabling the test pattern generator PCS\_TSTPAT\_GEN (3×002A.3). The period of the square wave can be controlled in terms of bit times by writing to PCS\_SQPW (3×8004). There is no associated square wave checker within the VSC8486-04. The pseudo-random test pattern is selected by deasserting PCS\_TSTPAT\_SEL (3×002A.1). The pseudo-random test pattern contains two data modes. When PCS\_TSTDAT\_SEL (3×002A.0) is deasserted, the pseudo-random pattern is a revolving series of four blocks with each block 128-bits in length. The four

blocks are the resultant bit sequence produced by the PCS scrambler when pre-loaded with the following seeds:

- PCS\_SEEDA (3×0022-3×0025)
- PCS\_SEEDA invert
- PCS\_SEEDB (3×0026-3×0029)
- PCS\_SEEDB invert

The pattern generator is enabled by asserting PCS\_TSTPAT\_GEN (3×002A.3), while the analyzer is enabled by asserting PCS\_TSTPAT\_ANA (3×002A.2). Errors are accumulated in the clear-on-read saturating counter, PCS\_ERR\_CNT (3×002B). In pseudo-random pattern mode, the error counter counts the number of errored blocks.

Support for the optional PRBS31 pattern is indicated by PCS\_PRBS31\_ABILITY (3×0020.2) whose default is high. The PRBS31 test generator is selected by asserting PCS\_PRBS31\_GEN (3×002A.4) while the checker is enabled by asserting PCS\_PRBS31\_ANA (3×002A.5). IEEE standards specify that the error counter should increment for each linear feedback shift register (LFSR) tap that a bit is in error. Therefore, a single bit error increments the counter by 3 as there are three taps in the PRBS31 polynomial.

The user defined 64-bit static pattern can be written to PCS\_USRPAT (3×8000-3×8003) and enabled by asserting PCS\_USRPAT\_ENA (3×8005.0) and PCS\_TSTPAT\_GEN (3×002A.3).

## 3.7 Extended Physical Coding Sublayer

The VSC8486-04 provides an optional Extended PCS (E-PCS) mode to improve link quality (BER), provide a supervisory channel, and monitor the error rate at the PHY level. The E-PCS feature utilizes the frame format specified in the Common Electrical I/O Protocol (CEI-P) document created as an Implementation Agreement (IA) within the Optical Network Forum's (OIF). The CEI-P maintains a similar EMI spectrum as that generated by a standard PCS. The E-PCS mode operates at the same line rate as PCS and therefore does not require any special clocks or changes to the PMD layer.

When enabled, E-PCS mode provides a net electrical coding gain (NECG) of approximately 2.5 dB. For example, a link operating without E-PCS at a BER of  $10^{-10}$  would operate at a BER of better than  $10^{-16}$  with E-PCS.

Electronic dispersion compensated (EDC) applications produce burst errors due to the commonly used decision feedback equalizer (DFE) architecture. DFEs typically used in 10GBASE-LRM produce burst errors that are typically the same bit length as the number of taps. E-PCS mode is capable of correcting burst-errors up to 7 bits in length, which is a common DFE tap size.

E-PCS mode is supported when the VSC8486-04 device is configured in LAN mode only, not in WAN mode.

### 3.7.1 Autonegotiation

The VSC8486-04 can be configured to autonegotiate between standard and extended PCS modes or can be controlled manually. The AUTONEG input pin, if set low, places the device into manual mode, meaning that E-PCS is enabled only when the EPCS input pin is set high. Both the AUTONEG and EPCS pins can be overridden by software by setting the AUTONEG\_OVR (1×E605.13) and EPCS\_OVR (1×E605.11) bits. Once overridden, the autonegotiation and E-PCS states are dependent upon the settings of AUTONEG\_FORCE (1×E605.12) and EPCS\_FORCE (1×E605.10).

In autonegotiation mode the device transmits in the format defined by the EPCS mode after reset or power-up. The high-speed received data is processed by both the PCS and the E-PCS. If the received format is different than the transmitted format, the device switches the format to match the received data. During a loss of lock (LOL), the device continues to transmit in the currently negotiated format, but

changes to a new format if the receiver detects one. The following table describes the logic of the EPCS and AUTONEG bits.

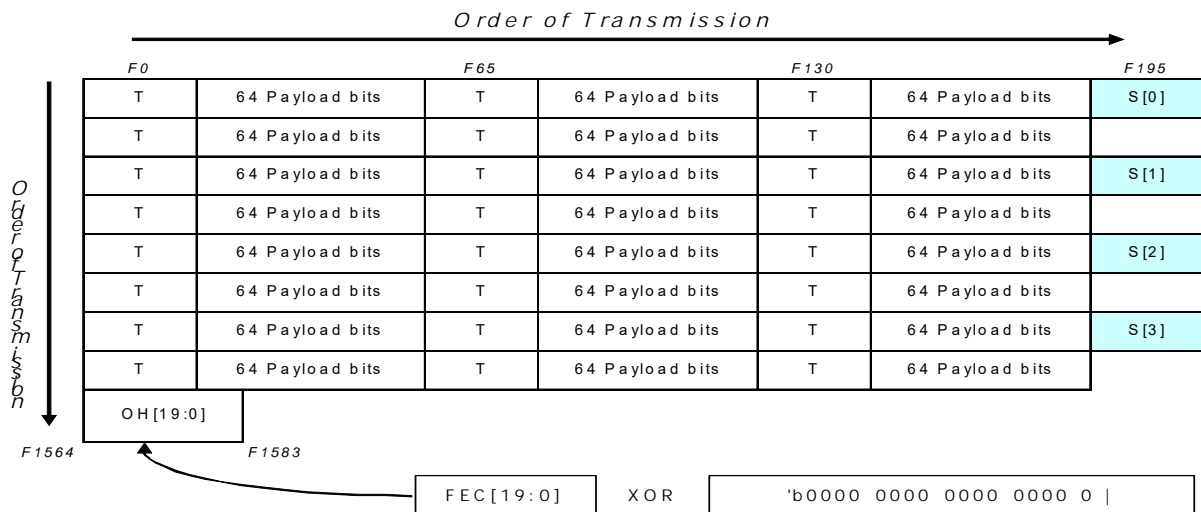
**Table 33 • E-PCS Logic**

EPCS	AUTONEG	Transmission Format
0	0	Standard PCS.
0	1	Device begins transmitting in standard PCS format, but switches to E-PCS format if and only if the receiver detects E-PCS format.
1	0	Extended PCS.
1	1	Device begins transmitting in E-PCS format, but switches to standard PCS if and only if the receiver detects PCS data.

### 3.7.2 Frame Format

The frame format for E-PCS mode is given in Section 4.2 of the OIF CEI-P. The two-bit overhead of the 64B/66B PCS frame is replaced with a single overhead bit, thereby freeing up one bit per PCS frame. By accumulating these saved bits over 24 PCS frames, there are 24 new bits available to implement the supervisory channel and FEC firecode. Seventeen of these bits (OH[19:3]) are used for framing, scrambler synchronization, error detection, and forward error correction. Three of these bits (OH[0:2]) are used to optionally determine link state and assist in error detection and forward error correction. Four of these bits (S[0:3]) are used as a supervisory channel.

**Figure 40 • E-PCS Frame Format**



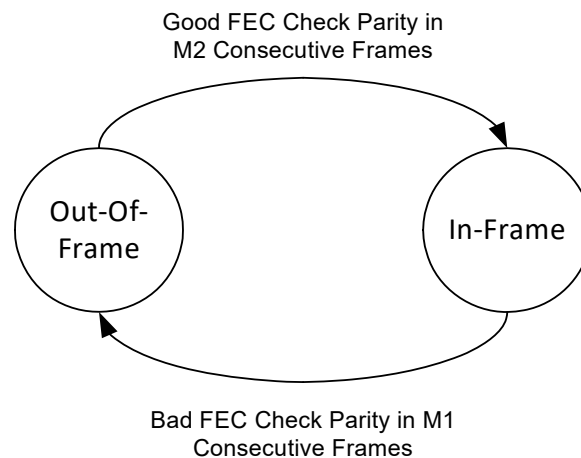
### 3.7.3 Link State Machines

The Rx and Tx Link training State Machines (LSMs) are compliant with the CEI-P specification. TX\_LSM (3xE604.7:5) reports the current state of the Tx Link State Machine. This state information can be used for diagnostics or monitoring of link training success. By default the Tx\_LSM\_ENA (3xE602.6) bit is deasserted, meaning that the Tx LSM skips the training sequence and handshake and moves directly to the idle state. If the VSC8486-04 is used in a system where training is desired, the Tx\_LSM\_ENA (3xE602.6) bit must be asserted during initial configuration. If Tx\_LSM\_ENA (3xE602.6) is asserted, the Tx LSM can be forced to restart and retrain the link by asserting TX\_LSM\_RESTART (3xE602.5). This bit has no value when operating with TX\_LSM\_ENA (3xE602.6) deasserted. Although intended for applications with multiple clients, the TX\_LSM\_HOLD (3xE602.4) is available for payload synchronization purposes. The TX\_LSM\_TIMEOUT (2xE603) value, also referred to as D1 in the CEI-P

specification, is used to progress the LSM from the training state to the operational state in the case of a simplex (uni-directional) link application.

Within the receive link state machine the current state is reflected in RX\_LSM (3×E605.2:0). The criteria for moving among Rx LSM states is based upon consecutive state indications being stable for a number of frames. This number, also known as the accepted value, is set in RX\_LSM\_R1 (3×E602.3:0) in units of CEI-P frames. The link's status of in-frame or out-of-frame is indicated in RX\_IN\_FRM (3×E605.4). The following illustration shows the E-PCS Framing State Diagram. The in-frame condition occurs when the number of consecutive E-PCS frames without parity errors (M2) exceeds 4. The out-of-frame condition occurs when the number of consecutive frames with parity errors (M1) exceeds 15.

**Figure 41 • E-PCS Framing State Diagram**



### 3.7.4 FEC Controls and Feedback

The forward error correction (FEC) code also known as the Firecode, occupies the last 20 bits within the E-PCS frame. Two counters are used to provide a rough indication of the link quality. The RX\_FIXED\_CNT (3×E605) frame counter displays the number of E-PCS frames in which errors were corrected over the previous one second. The RX\_UNFIXED\_CNT (3×E606) frame counter increments upon each E-PCS frame where the number of errors exceed the Firecode algorithm, namely an error burst greater than 7 bits per frame. The user must assert LATCH\_N\_CLR\_CNT (3×E601.1) to latch the internal counter values into the MDIO accessible registers and clear the internal counters.

For purposes of BER characterization, the error correction mechanism can be disabled by deasserting EPCS\_CORR (3×E601.2). By default, error correction is enabled.

### 3.7.5 Supervisory Channel

The four supervisory channel bits per E-PCS frame can be set for two different configurations. The first configuration involves sending static values as defined in TX\_SCHAN (3×E601.7:10). These static bits are enabled by TX\_SCHAN\_EN (3×E601.6). The second configuration, which is the default, involves sending a 136-bit repeating message in a bit-wise fashion utilizing S[0]. In this mode, S[3:1] are automatically set to zero. The 136-bit message contains 8-bits of framing (0×7E) and a 128-bits of user programmable area. The intended 128-bit message is programmed in TX\_MSG (3×E60A–3×E611). Once the message is programmed, the user must assert the TX\_NEW\_MSG (3×E601.0) bit. This action latches the 128-bit message into internal registers, which are serialized and repetitively streamed out in the S[0] bit.

In the received direction, the S[0] bit is monitored for the framing byte (0×7E) to appear 136-bits apart, which is defined as frame alignment. After alignment, the incoming message bits are written to RX\_MSG (3×E612-3×E619). Whenever the previous message and the current message differ, the RX\_NEW\_MSG (3×E604.3) bit asserts.

It is important to note that with a simplistic framing algorithm based upon a single byte (0x7E) occurring repeatedly 136-bits apart, any message containing the 0x7E byte can cause a false frame alignment. In such a case software must reconstruct the intended message.

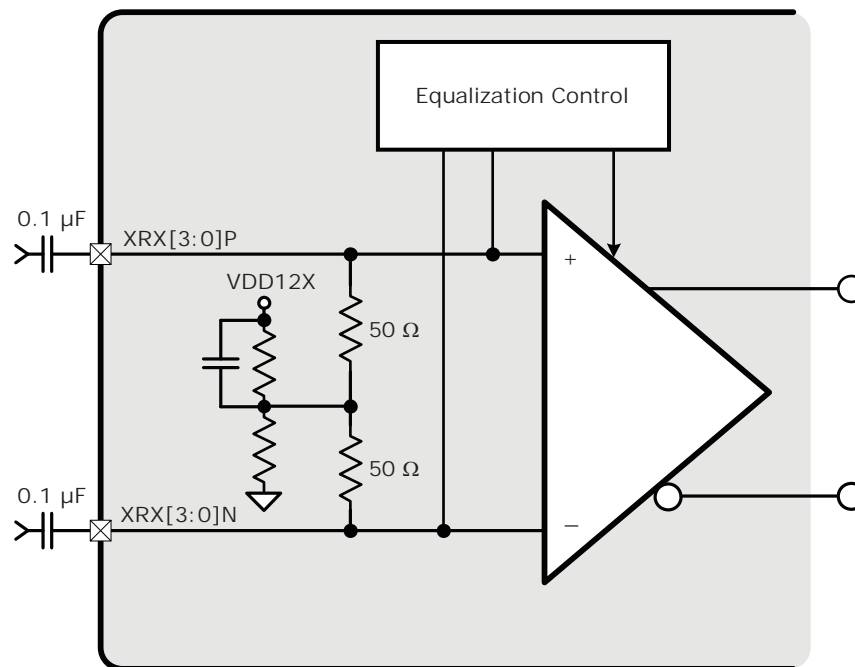
## 3.8 XGMII Extender Sublayer

The PHY XS block interfaces from the four-lane 10 Gbps attachment unit interface (XAUI) to the PCS. Each AC-coupled lane has 8b/10b encoded data running at 3.125 Gbps (3.1875 Gbps for 10 GFC).

### 3.8.1 XAUI Receiver

The XAUI interface features on-chip terminations of 100  $\Omega$  for all XAUI inputs, as shown in the following illustration.

Figure 42 • XAUI Input Simplified Schematic



### 3.8.2 XAUI Loss of Signal

Each XRX[3:0]P/N channel's input buffer has a loss of signal (LOS) detection that can be accessed through the MDIO registers (4x8012.3:0). For each XAUI lane, a loss of signal level status is set low when the differential signal peak-to-peak swing exceeds the global deassert threshold level for that lane. The XAUI LOS assert and deassert thresholds cannot be set independently. Two bits in register (4x8011.3:2) are used to program four separate deassert and assert level ranges, as shown in the following table.

For each lane, a high indicates that the signal amplitude is below the assert threshold level. The LOS status bits are considered undefined when the signal swing is between the deassert threshold and assert threshold.

The approximate upper (deassert) and lower (assert) threshold levels are shown in the following table.

**Table 34 • XAUI Lane LOS Threshold Summary**

LOS Assert/ Deassert Threshold Range (4×8011.3:2)	Assert Threshold (mV)	Deassert Threshold (mV)	LOS Status (4×8012.3:0)	Remarks
00 (default)	50	175	Lane 3; bit 3 Lane 2; bit 2 Lane 1; bit 1 Lane 0; bit 0	For each lane: 1: LOS declared 0: LOS not declared
01	60	185	Lane 3; bit 3 Lane 2; bit 2 Lane 1; bit 1 Lane 0; bit 0	For each lane: 1: LOS declared 0: LOS not declared
10	70	195	Lane 3; bit 3 Lane 2; bit 2 Lane 1; bit 1 Lane 0; bit 0	For each lane: 1: LOS declared 0: LOS not declared
11	80	205	Lane 3; bit 3 Lane 2; bit 2 Lane 1; bit 1 Lane 0; bit 0	For each lane: 1: LOS declared 0: LOS not declared

### 3.8.3 XAUI Receiver Equalization

Incoming data on the XRX[3:0]P/N inputs typically contains a substantial amount of intersymbol interference (ISI) or deterministic jitter, which reduces the ability of the receiver to recover data without errors. Each XAUI lane includes a programmable equalizer circuit designed to effectively reduce the ISI resulting from copper cables or long printed circuit board (PCB) traces. XAUI lane equalization settings are programmed by writing to the appropriate bits in register LANE\_EQ (4×8010.15:0) as shown in the following table.

**Table 35 • XAUI Receiver Lane Equalization Setting**

EQ Control Bits Per Lane	EQ Setting Per Lane	Remarks
Lane 3 (4×8010.3:0)	0000: 0.0 dB (default)	Optimum XAUI lane equalization settings are application specific. Typically, micro-strip traces require less equalization to compensate because of lower losses than stripline construction. Normally, no equalization adjustment is required for XAUI tracks less than approximately 3 inches in FR-4 (microstrip or stripline). Beyond 3 inches, some amount of equalization is recommended for best performance.
Lane 2 (4×8010.7:4)	0001: 1.4 dB	
Lane 1 (4×8010.11:8)	0010: 2.2 dB	
Lane 0 (4×8010.15:12)	0011: 2.8 dB	
	0100: Not defined	
	0101: 4.5 dB	
	0110: 5.4 dB	
	0111: 6.1 dB	
	1000: Not defined	
	1001: 6.2 dB	
	1010: 7.1 dB	
	1011: 7.8 dB	
	1100: Not defined	
	1101: 10.0 dB	
	1110: 10.8 dB	
	1111: 11.6 dB	



### 3.8.4 XAUI Clock and Data Recovery

At the XAUI receiver, each channel contains an independent clock recovery unit (CRU) that accepts the selected serial input source, extracts the high-speed clock, and retimes the data. Each CRU automatically locks on to data and, if the data is not present, it automatically locks to the reference clock. The clock recovery unit must perform bit synchronization, which occurs when the CRU locks onto and properly samples the incoming serial data.

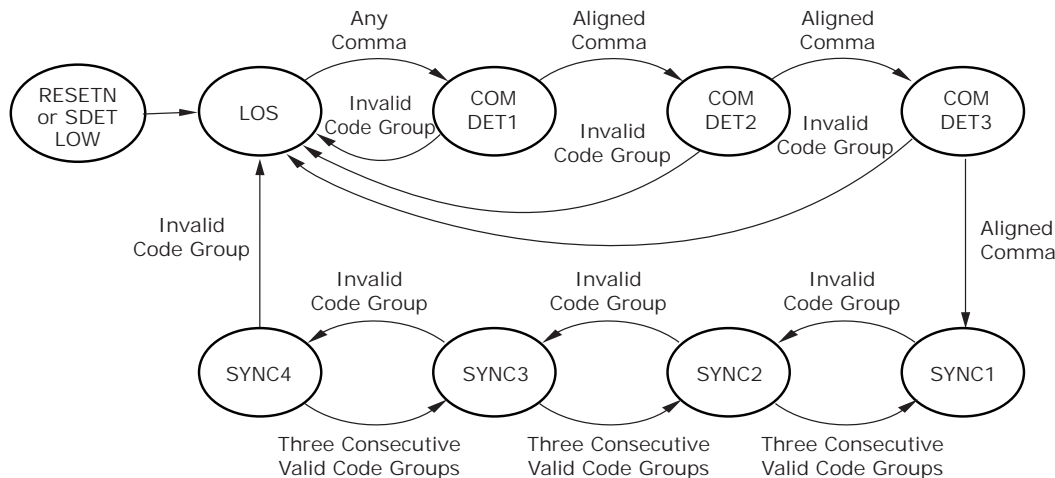
### 3.8.5 XAUI Code Group Synchronization

The retimed serial data stream is delineated into 10-bit code groups by the deserializer. A special 7-bit comma pattern, 0011111xxx or 1100000xxx (where x is don't care), is recognized by the receiver as a 10-bit code group boundary.

Character, or code group, alignment occurs when the deserializer synchronizes the 10-bit code group boundary to a comma pattern in the incoming serial data stream. If the receiver identifies a comma pattern in the incoming data stream that is misaligned to the current framing boundary and the receiver is in LOS state, the receiver re-synchronizes the recovered data to align the data to the new comma pattern. Re-synchronization ensures that the comma character is output on the internal 10-bit bus so that bits 0 through 9 equal 0011111xxx or 1100000xxx. If the comma pattern is aligned with the current framing boundary, then the re-synchronization does not change the current alignment.

The detection of a series of consecutive 10-bit code group violations is the mechanism by which loss of synchronization, LANE\_SYNC (4x0018.3:0), is declared by the XAUI receiver. The loss of synchronization condition is cleared by the detection of a series of comma characters that are properly aligned on code group boundaries. For additional information, see IEEE Standard 802.3ae Clause 48, Figure 48-7 and the following illustration.

Figure 43 • LOS State Diagram



Comma detection is enabled only when in the loss of synchronization (LOS) state rather than at all times. This is desirable to prevent incorrect character realignment due to the appearance of false commas, resulting from single-bit errors.

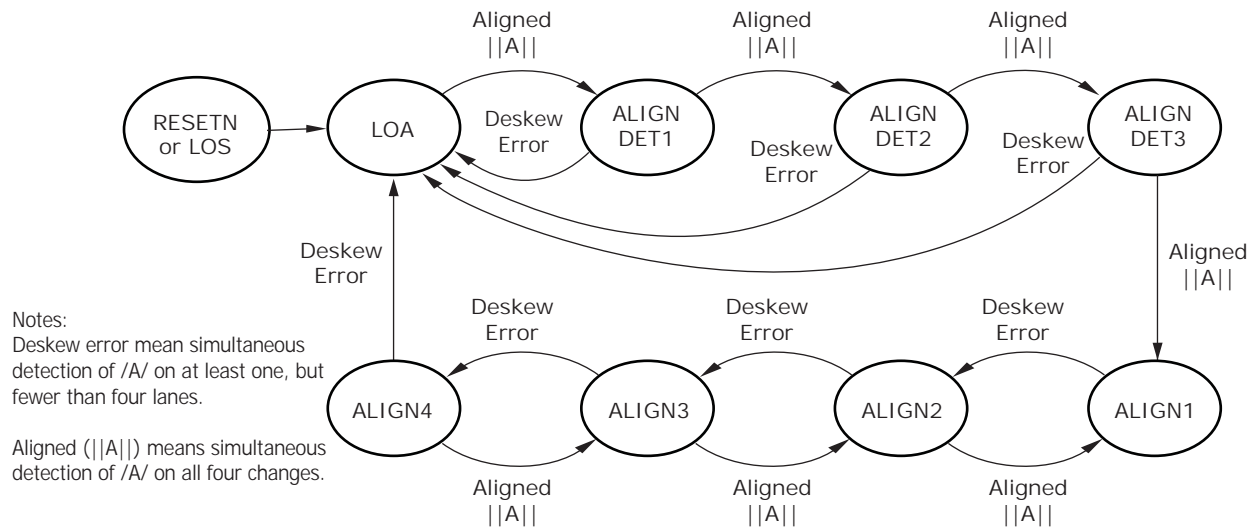
### 3.8.6 XAUI Lane Deskew

XAUI lane skew occurs due to the skew between channels of a XAUI transmitter and the skew accumulated across the transmission medium. The VSC8486-04 can deskew up to 63-bit periods of lane-to-lane skew by using elastic buffers. XAUI channel lane deskew is performed by detecting the alignment character /A/ on all four lanes. The PHY XS LANES\_ALIGNED bit (4x0018.12), when read as one, indicates all lanes are aligned.

For inter-channel alignment to occur, the ||A|| ordered set consisting of four /A/ code groups must appear, one /A/ on each of the four XAUI lanes. This provides a unique synchronization point across the four serial data streams, which are used to align the received channels. Alignment status is governed by the

reception of  $||A||$  ordered sets across the inputs, as shown in the following loss of alignment (LOA) state diagram.

**Figure 44 • LOA State Diagram**



Successive synchronization points must be separated by at least 170 bit periods in order for up to 63 bit periods of lane to lane skew to be corrected unambiguously. An IEEE compliant source of XAUI data provides a minimum spacing between sync points of 17 code groups, or 170 bit periods (at least 16 other IDLE code groups must occur between consecutive occurrences of  $||A||$ ). The alignment mechanism is always enabled when code group synchronization is attained on all four channels.

### 3.8.7 10b/8b Decoder

The 10-bit code group from the deserializer is decoded in the 10b/8b decoder, which outputs the data and control bits to the physical coding sublayer (PCS).

If the 10-bit code group does not match a valid code, a code group error is generated that increments the code group error counter GRPERR\_CNT\_LSW/MSW (4×8003/4×8004). Similarly, if the running disparity of the code group does not match the expected value, a disparity error is generated that increments a running disparity error counter DISPERR\_CNT\_LSW/MSW (4×8006/4×8007).

### 3.8.8 8b/10b Encoder and Serializer

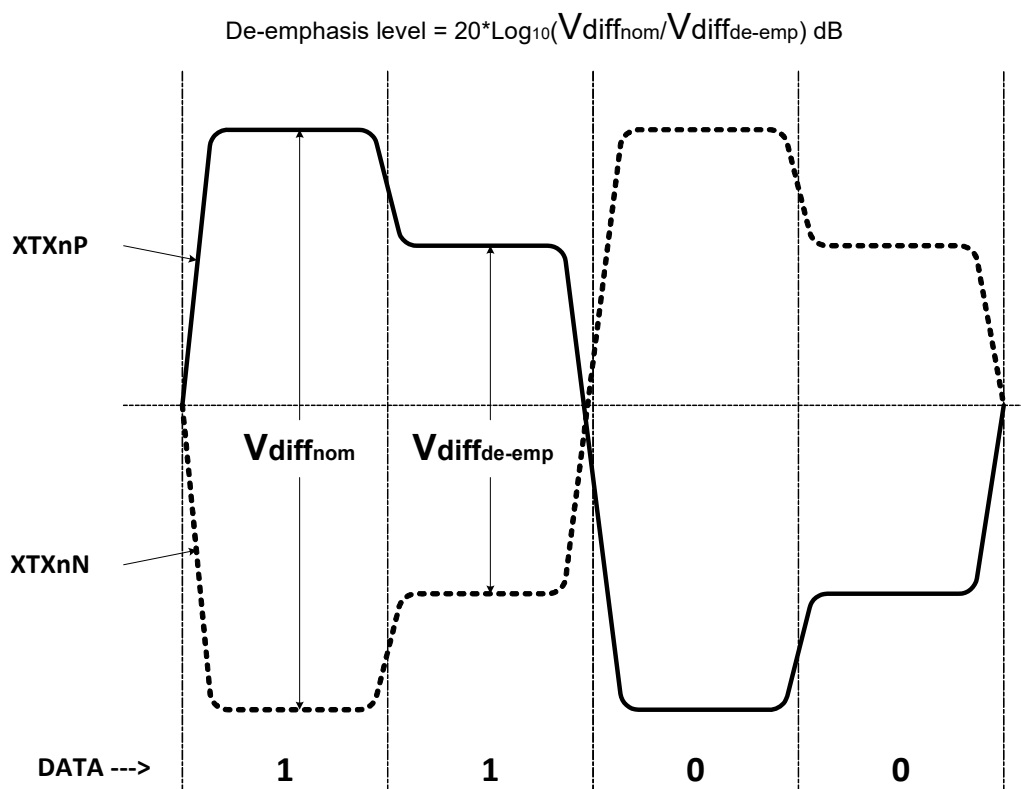
Each channel contains an 8b/10b encoder that translates 8-bit data fed internally from the PCS block into a 10-bit code word. This data is then routed into a multiplexer that serializes the word, using the synthesized transmit clock. The most significant bit of the 10-bit data is transmitted first. Each channel has a serial output port, XTX[3:0]P/N, which consists of a differential XAUI output buffer operating at 3.125 Gbps (3.1875 Gbps for 10 GFC).

### 3.8.9 XAUI Transmitter

On the XAUI PHY transmit side (XTX[3:0]P/N), each polarity of the CML-type output driver is back-terminated with 50  $\Omega$  to VDDA12, providing a 100  $\Omega$  differential output impedance.

### 3.8.10 XAUI Transmitter Pre-Emphasis

The XAUI output stages include programmable peaking of the transmitted signal for each lane called pre-emphasis. The following illustration shows the pre-emphasis waveform definition.

**Figure 45 • XAUI Output Differential Voltage with Pre-emphasis**


When used, transmit pre-emphasis causes the XAUI transmitter signals to be shaped to mitigate skin effect distortion, as shown in the preceding illustration. When signal pre-emphasis is employed, the effects of pre-distortion and skin effect distortion offset each other, and a higher quality waveform results at the receiving device.

XAUI lane pre-emphasis settings are programmed by writing to the appropriate bits in XAUI\_PE\_CFG (4×8011), as shown in the following table. Optimum XAUI lane pre-emphasis settings are application-specific. Normally no pre-emphasis adjustment is required for XAUI tracks less than approximately 5 inches in FR-4 (microstrip or stripline). Beyond about 5 inches, some amount of pre-emphasis is recommended for best performance.

**Table 36 • XAUI Transmitter Lane Pre-emphasis Setting**

Pre-emphasis Control Bits	Pre-emphasis Setting Per Lane
Lane 3 (4×8011.5:4)	00: 0.0 dB (default)
Lane 2 (4×8011.8:7)	01: 2.5 dB
Lane 1 (4×8011.11:10)	10: 6.0 dB
Lane 0 (4×8011.14:13)	11: 12.0 dB

### 3.8.11 XAUI Transmitter Programmable-Output Swing

All XAUI output lanes include two peak-to-peak voltage swing settings. Asserting HS\_ENA (4×8011.1) increases the output swing on all lanes by approximately 20% over the default output swing.

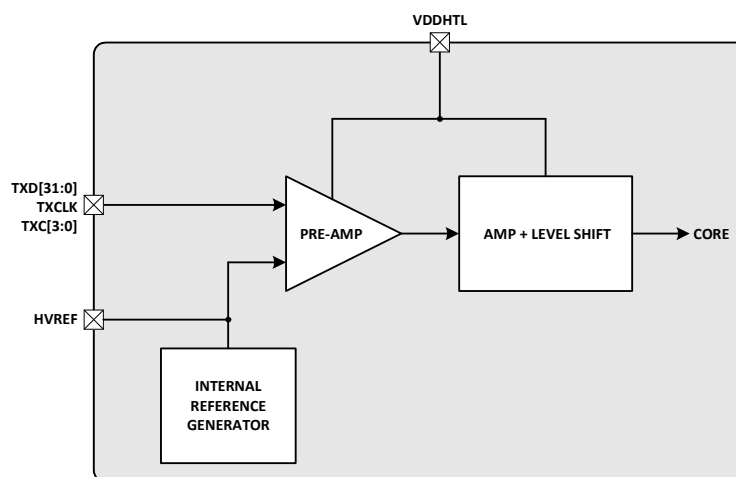
### 3.8.12 XGMII Tx Input Interface

The VSC8486-04 expects to receive a continuous stream of data and control characters from the MAC or 10 GFC equivalent at the XGMII input. The XGMII interface is organized into four groups of eight data

bits (octet) and one control bit. Octets originating from a MAC device are received on TXD[31:0] in octet-striped fashion with the first octet appearing on TXD[7:0] (lane 0), the second on TXD[15:8] (lane 1), and so forth. Within the octets, bit ordering is set so that bit 0 of a serial bit stream appears on TXD0, bit 1 appears on TXD1, and so forth. Within each octet, the lowest-numbered bit (bit 0 in the first octet, bit 8 in the second octet, etc.) is considered the LSB.

XGMII data is latched into the VSC8486-04 on both the rising and falling edges of TXCLK, which serves as a timing reference for the transfer of TXD[31:0] and TXC[3:0] across the XGMII interface. TXCLK is 156.25 (159.375) MHz clock,  $\pm 100$  ppm. The XGMII interface follows the high-speed transceiver logic (HSTL) electrical specifications for a 1.5 V supply voltage, as specified in EIA/JESD8-6 for Class I output buffers. The HSTL inputs are designed to function with or without termination. For the specifications and timing diagrams, see [XGMII Specifications](#), page 198. Simplified diagrams of the XGMII input and output structures are illustrated in the following illustration.

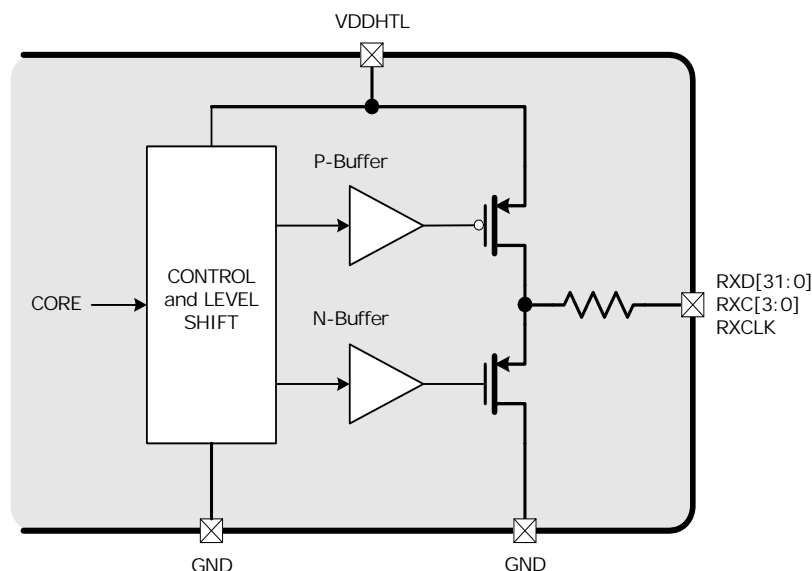
**Figure 46 • XGMII Input Simplified Schematic**



### 3.8.13 XGMII Rx Output Interface

The VSC8486-04 provides a continuous stream of data and control characters to the MAC or 10GFC equivalent on its XGMII outputs. The XGMII interface is organized into four groups of eight data bits (octet) and one control bit. Octets originating from the PCS block are transmitted on RXD[31:0] in octet striped fashion, with the first octet appearing on RXD[7:0] (lane 0), the second on RXD[15:8] (lane 1), and so forth. Within the octets, bit ordering is such that bit 0 of a serial bit stream appears on RXD0, bit 1 appears on RXD1, and so forth. Within each octet, the lowest-numbered bit (bit 0 in the first octet, bit 8 in the second octet, and so forth.) is considered the LSB.

XGMII data is latched to the output of the VSC8486-04 on both rising and falling edges of RXCLK, which serves as a timing reference for the transfer of RXD[31:0] and RXC[3:0] across the XGMII interface. The RXCLK output is 156.25 MHz (159.375 MHz)  $\pm 100$  ppm. The XGMII interface follows the high-speed transceiver logic (HSTL) electrical specifications for a 1.5 V supply voltage, as specified in the EIA/JESD8-6 for Class I output buffers. The HSTL outputs are designed to function with or without termination and swing from the ground rail to the power supply rail without termination. For more information about specifications and timing diagrams, see [XGMII Specifications](#), page 198. For more information about the simplified diagrams of the XGMII output structures, see the following diagram.

**Figure 47 • XGMII Output Structure and Termination**


**Note:** During normal operation, simultaneous switching output (SSO) noise generated inside the XGMII block may be higher than expected. SSO noise impairs XGMII output at the output buffers, resulting in apparently high jitter and violation of setup and hold times. However, the clock and data signals are actually moving in the same direction when power supplies fluctuate, which happens with SSO injection. Because clock and data are tracking each other, the setup and hold times for every individual clock cycle maintain a tight relationship. Specified setup and hold times will be met when ripple noise from the external power supply for HSTL logic is kept under 30 mV and clock and the data trace lengths are within 7 cm. For more information about TXCLK and TXCLK timing parameters, see [Table 310](#), page 199.

## 3.9 MDIO Serial Interface

The VSC8486-04 contains a management data input/output (MDIO) interface, as specified in IEEE Standard 802.3ae Clause 45. This section provides an overview of the operation of the MDIO interface. For more information, see IEEE Standard 802.3ae Clause 45.

### 3.9.1 MDIO Interface Operation

The operational sublayers within the device are individually known as MDIO-manageable devices (MMDs). Using the PRTAD[4:0] pins, the station management entity (STA) can access up to 32 PHYs. Using the 5-bit DEVAD field within the management frame format, up to 32 MMDs can be addressed in each PHY. The MDIO-manageable device addresses are shown in the following table.

**Table 37 • MDIO-Manageable Device Addresses**

Device Address	MMD Name
0	Reserved
1	PMA
2	WIS
3	PCS
4	PHY XS
5	DTE XS (not implemented)
6:29	Reserved

**Table 37 • MDIO-Managed Device Addresses (continued)**

Device Address	MMD Name
30	Vendor-specific name for two-wire serial CPU interface
31	Vendor specific name

The management frame format supports indirect addressing to provide more accessible register space within each MMD. For more information, see [Figure 48](#), page 74. The management frame field structure is shown in the following table.

**Table 38 • Management Frame Format for Indirect Register Access**

Management Frame Fields							Address/Data	Idle
Frame	PRE	ST	OP	PRTAD	DEVAD	TA		
Address	1...1	00	00	PPPPP	EEEE	10	AAAAAAAAAAAAAAAA	Z
Write	1...1	00	01	PPPPP	EEEE	10	DDDDDDDDDDDDDDDD	Z
Read	1...1	00	11	PPPPP	EEEE	Z0	DDDDDDDDDDDDDDDD	Z
Read increment	1...1	00	10	PPPPP	EEEE	Z0	DDDDDDDDDDDDDDDD	Z

A 16-bit address register stores the address of the register to be accessed by data transaction frames. The address register is overwritten by address frames. Upon device-reset, the contents of the address register is set to zero. At power up, the contents of the address register are undefined.

Write, read, and post-read-increment-address frames access the register whose address is stored in the address register. Write and read frames do not modify the contents of the address register.

After receiving a post-read-increment-address frame and completing the read operation, the address register is incremented by one. When the register contains 65,535, the address register is not incremented.

The idle condition is a high-impedance state. All tri-state drivers are disabled, and the pull-up resistor pulls the MDIO line to a one.

At the beginning of each transaction, the station management entity (STA) sends a preamble (PRE) sequence of 32 continuous one-bits on MDIO during 32 corresponding cycles on the management data clock (MDC), providing a pattern that the MMD uses to establish synchronization. All MMDs observe the 32 continuous one-bits before responding to any transaction.

**Figure 48 • MDIO Frame Format**

PRE 32	ST	OP	PA 5	DA 5	TA	D 16	Z
--------	----	----	------	------	----	------	---

The MDIO frame format consists of the eight segments, shown above. Definitions for the segments are shown in the following table.

PRE 32	32 bits of 1 supplied by the STA.
ST	2 bits of 0, which indicates the start of frame.
OP	2 bits of Op-Code as described in IEEE 802.3ae Clause 45.
PA 5	5 bits of port address, which provides up to 32 ports to a physical bus.
DA 5	5 bits of destination MMD address, which provides up to 32 MMDs to a port.
TA	2 bits of turnaround time to change the bus ownership from the STA to MMD if required.
D 16	16 bits for address/data driven on the bus by the current master of the bus, the STA for write operation, and the MMD for a read or read-address-increment operation.
Z	Idle time, bus tri-stated.

The start of frame (ST) is indicated by the '00' pattern. Frames containing the ST = '01' pattern that is defined in IEEE Standard 802.3ae Clause 22, are ignored.

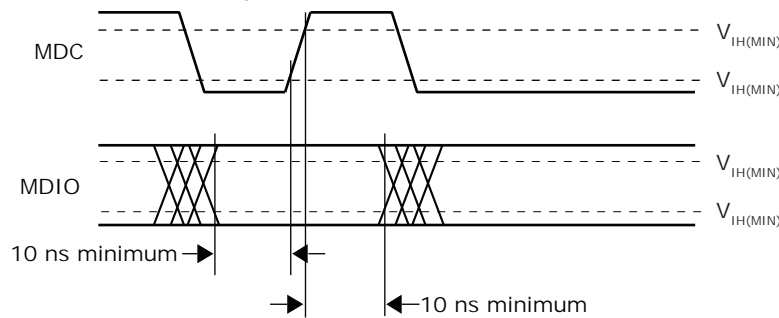
The operation code (OP) indicates the type of transaction being performed by the frame. A '00' pattern indicates that the frame payload contains the address of the register to access. A '01' pattern indicates that the frame payload contains data to be written to the register whose address is provided in the previous address frame. A '11' pattern indicates that the frame is a read operation. A '10' pattern indicates that the frame is a post-read-increment-address operation.

The port address (PRTAD) consists of five bits. The first bit to be transmitted and received is the MSB. The device address (DEVAD) also consists of five bits. The first bit transmitted and received is the MSB.

Turnaround (TA) is a two-bit time spacing between the DEVAD field and data field of a frame to avoid contention during a read transaction. For a read or post-read-increment-address transaction, the STA and MMD remain in a high-impedance state for the first-bit time of the turnaround. The MMD drives a zero bit during the second bit time of the turnaround of a read or post-read-increment-address transaction. During a write or address transaction, the STA drives a one for the first bit time of the turnaround and a zero for the second bit time of the turnaround.

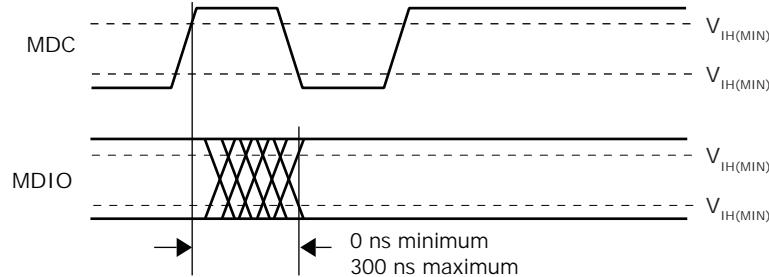
The address or data field consists of 16 bits. For an address cycle, it contains the address of the register to be accessed on the next cycle. For read, write, and increment read cycles, the field contains the data for the register. The first bit transmitted and received is bit 15.

MDIO is a bidirectional signal that can be sourced by STA or the MMD. When STA sources the MDIO signal, a minimum of 10 ns of setup time and 10 ns of hold time with reference to the rising edge of MDC is provided, as shown in the following illustration.

**Figure 49 • Timing with MDIO Sourced by STA**

When MDIO is sourced by the MMD, it is sampled by the STA synchronously with respect to the rising edge of MDC. The clock-to-output delay from the MMD, as measured at STA, is a minimum of 0 ns and a maximum of 300 ns, as shown in the following illustration. For MDIO data sourcing, the last MDC of the STA must provide a falling edge before the MDC is tri-stated. Without this falling edge, the last bit of data sourced by the MMD write cycle will not be completed.

**Figure 50 • Timing with MDIO Sourced by MMD**

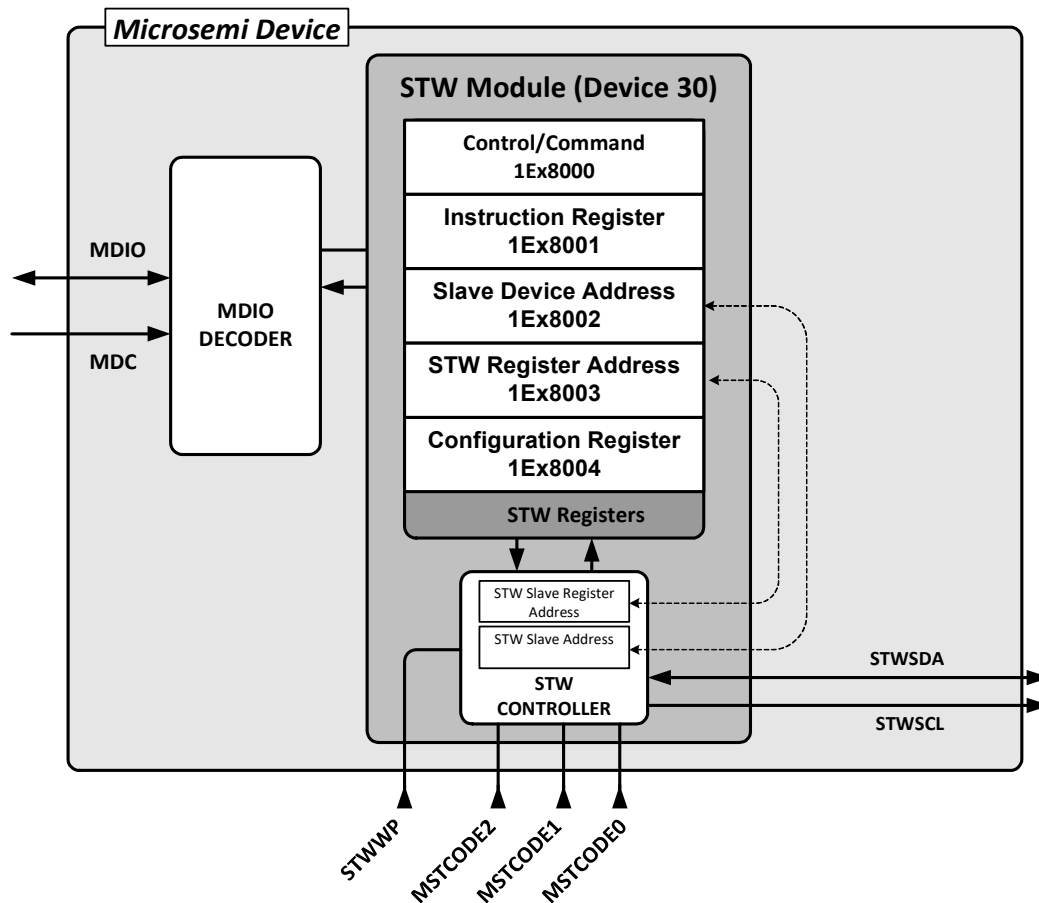


### 3.10 Two-Wire Serial Interface

The VSC8486-04 contains a two-wire serial management interface that provides a communication bus to slave peripherals such as non-volatile registers (NVR) or digital optical monitor (DOM) devices. The bus is intended to facilitate serial communication within a XENPAK/X2 module or with an XFP-compliant device; however, other devices can also be used. The two-wire serial bus is controlled using the MDIO interface. The two-wire serial interface is an industry-standard, master-only controller and supports two rates: standard (100 kbps) and fast (400 kbps). The MDIO control registers are shown in the following illustration.



Figure 51 • Serial Management Interface



The two-wire serial interface uses a bidirectional data and clock signal named STWSDA and STWSCL, respectively. The two-wire serial write protect pin STWWP, when pulled high, inhibits two-wire serial write activity.

The two-wire serial interface controller supports 7-bit addressing, as configured in STW\_ADDR\_MODE (1E×8004.11).

Writing to the MDIO register STW\_CTRL1 (1E×8000) initiates activity on the two-wire serial interface. The device supports automatic mode of operation, in which up to 256 bytes are automatically copied from an external NVR device to the internal two-wire serial interface registers or vice versa.

The two-wire serial controller logic operates independently from the MDIO interface. Thus, when the MDIO initiates a two-wire serial read/write command, the MDIO logic is not halted or locked while waiting for the two-wire serial command to complete. Because there is no queuing of two-wire serial commands, station management software must poll the two-wire serial controller to ensure that each two-wire serial command is complete before initiating the next command.

### 3.10.1 Two-Wire Serial Controller

The two-wire serial bus is controlled using five registers located in device 30 (0×1E).

#### 3.10.1.1 STW\_CTRL1 (1E×8000)

This register is the same as the NVR Control/Status register x8000 defined in XENPAK MSA Revision 3.0, with one exception. In addition to the XENPAK defined structure, the VSC8486-04 uses bit 8 of this register to set the two-wire serial interface operational mode. The MDIO decoder activates the two-wire serial interface module by writing to this register. Writes to this register through MDIO during a two-wire serial interface action are ignored.

### 3.10.1.2 STW\_DEVADDR (1E×8002)

This register stores the two-wire serial slave device address that is read or written. The 7-bit address is entered into bits 6:0 in the register. The two-wire serial controller does not directly use the register contents, but instead latches the contents into internal logic when SYNC\_ADDR (1E×8001.9) is asserted. This allows the address register to be updated while the two-wire serial controller is active. All XFP modules use the same seven-bit address 0×A0, which, when entered into the registers, become 0×50.

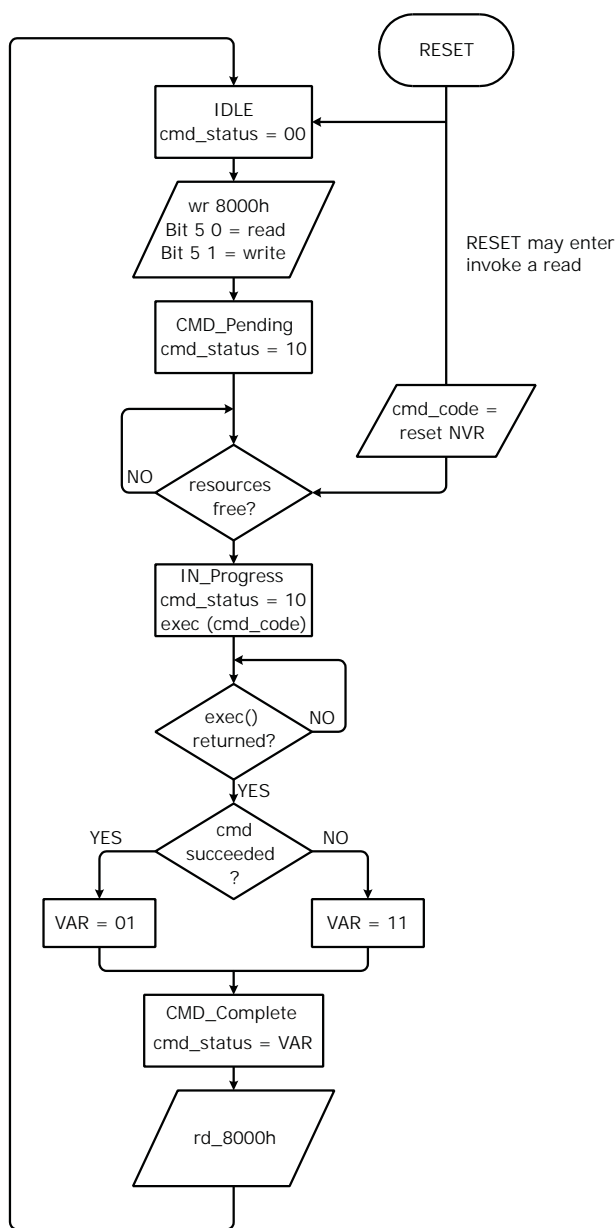
### 3.10.1.3 STW\_REGADDR (1E×8003)

This register is used to store the address of the two-wire serial target register, which is used to store the data read from or written to the slave device. Similar to register 1E×8002, this register is not directly used by the two-wire serial controller, but is latched into internal logic when SYNC\_REGADDR (1E×8001.8) is asserted.

### 3.10.1.4 STW\_CFG1 (1E×8004)

This register is used to configure the desired operating mode for the two-wire serial controller. Bits 11:9 configure the two-wire serial interface master bus controller operating characteristics, bus signaling speed, and addressing mode. Bit 12 sets the two-wire serial controller to make block reads or writes in accordance with the XENPAK or XFP register maps. The XFP or XENPAK register contents are mapped into 256 eight-bit registers beginning at internal address 1E×8007 and ending with 1E×8106.

The two-wire serial controller is initiated by writing to the STW\_CTRL1 (1E×8000). After each transaction begins the controller updates the STW\_CMDSTAT (1E×8000.3:2) field with a '10' command in progress status. In this state, the MDIO interface cannot read or write to the two-wire serial control registers. After the controller completes the data read or write transaction, the STW\_CMDSTAT (1E×8000.3:2) field is updated to either '01' to reflect a successful operation or '11' to reflect a failed operation. The MDIO interface then regains access to the two-wire serial controller registers. The following illustration shows the state diagram of the two-wire serial controller.

**Figure 52 • Two-Wire Serial Access State Diagram**


### 3.10.2 Automatic Mode

Automatic mode provides easy access to non-volatile registers (NVR), such as EEPROM, used in XENPAK and XFP modules. In automatic mode, the two-wire serial interface controller performs reads or writes to different sections of non-volatile memory according to the value of the extended command bits, **STW\_EXT\_CMD** (1E×8000.1:0). A value of '11' reads or writes all NVR contents, which is compliant with XENPAK MSA revision 3.0, section 10.10. **STW\_CMD** (1E×8000.5) determines whether the operation is read or write.

In automatic mode, the two-wire serial interface maps internal registers 1E×8007 through 1E×8106 to external NVR address 0 to 255. To perform an automatic read, first write **STW\_DEVADDR** (1E×8002), and then write **STW\_CTRL1** (1E×8000) using the proper settings. The two-wire serial interface controller reads the data stored in a certain section of NVR, which is defined by **STW\_EXT\_CMD** (1E×8000.1:0), and saves data to the corresponding section of internal VSC8486-04 registers. For example, if the data written to **STW\_CTRL1** (1E×8000) is 0×0000, the two-wire serial interface controller reads XFP

EEPROM bytes 2-57, and stores the data in registers 1E×8009 to 1E×8040. The automatic write operation is similar.

The auto read or write operations are compatible with the ATMEL AT24Cxx series serial two-wire EEPROM. For a detailed description of the read or write operations, see the ATMEL AT24Cxx Series Two-Wire Serial EEPROM specification. After the read or write operation is complete, the two-wire serial interface controller writes to STW\_CMD\_STATUS (1E×8000.3:2) to set the appropriate code. A '01' indicates a successful operation, and a '11' indicates a failed operation.

Use the following procedure to perform an automatic block read operation:

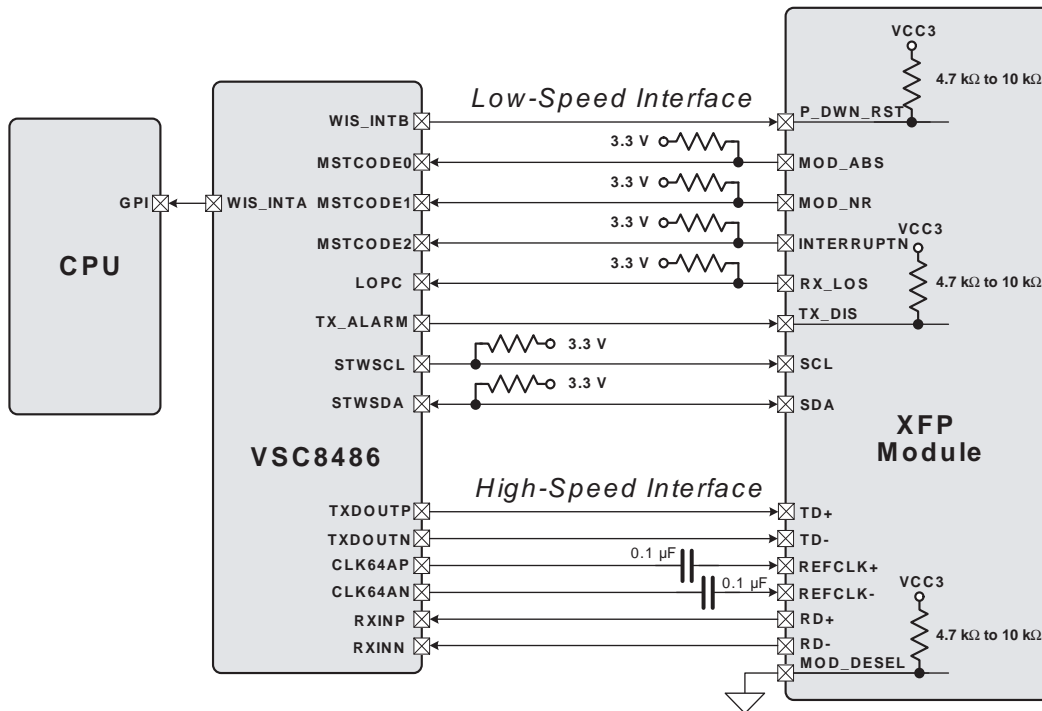
1. Write the address of the slave device to the Slave Device Address register (1E×8002) (50'h for XFP modules).
2. Write to the configuration register (1E×8004) bit 12 = 1 (XFP module).
3. Write 0×0000 to STW\_CTRL1 (1E×8000). XFP bytes 2 through 57 are auto read.

### 3.11 XFP or SFP+ Module Interface

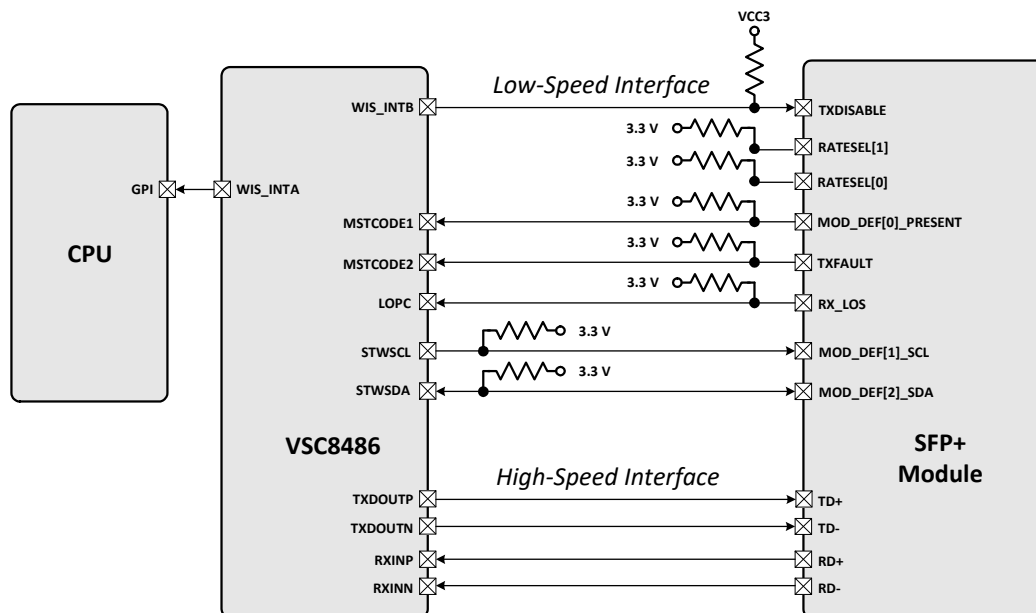
Several VSC8486-04 I/O pins can be reconfigured (using MDIO) from their default function to interface with all of the XFP or SFP+ status and control I/O pins, including the two-wire serial bus.

In an XFP host application, the recommended pin connections are as shown in the following illustration.

Figure 53 • VSC8486-04 to XFP Host Recommended Interface Connections



In an SFP+ host application, the recommended pin connections are as shown in the following illustration.

**Figure 54 • VSC8486-04 to SFP+ Host Recommended Interface Connections**


**Note:** To avoid a criss-cross in the connection to SFP+, it is recommended the TXDOUTP/N polarity be swapped. To program the TXDOUTP/N polarity, use register 1×8000.7.

Each of the recommended low-speed interface signals used on the VSC8486-04 in an XFP or SFP+ host application are summarized in the following table.

**Note:** Because the VSC8486-04 device operates at 10 gigabits, the SFP+ module pins KSO (pin 7) and RS1 (pin 9) should be tied high externally.

**Table 39 • XFP or SFP+ Host Application Pin Connections Summary**

VSC8486-04 Pin	I/O	Default Operation	XFP Host Operation	SFP+ Host Operation	Comments
WIS_INTB	Open-drain output	XFP module P_DWN_RST	XFP module P_DWN_RST	SFP+ module TXDISABLE	Pull-up resistor provided inside the XFP or SFP+ module. See register 1×E902.2:0 and 1×E901.9 for additional options. Polarity invert (1×E902.1 and 1×E605.15).
MSTCODE0 <sup>1</sup>	LVTTTL input	Two-wire serial high-speed master code0	MOD_ABS	Not used with SFP+	See interrupt pending register (2×EF00.14:12) and mask (2×EF01.14:12) and pin status (1×E607.15:13).
MSTCODE1 <sup>1</sup>	LVTTTL input	Two-wire serial high-speed master code1	MOD_NR	GPIO_PRESEN T	See interrupt pending register (2×EF00.14:12) and mask (2×EF01.14:12) and pin status (1×E607.15:13).
MSTCODE2 <sup>1</sup>	LVTTTL input	Two-wire serial high-speed master code2	INTERRUPTN	GPIO_TXFAULT	See interrupt pending register (2×EF00.14:12) and mask (2×EF01.14:12) and pin status (1×E607.15:13).
LOPC	LVTTTL input	Loss of optical signal	Loss of optical signal	Loss of optical signal	Provide pull-up externally, nominally 4.7 kΩ. Provide pin status on 1×E607.0.

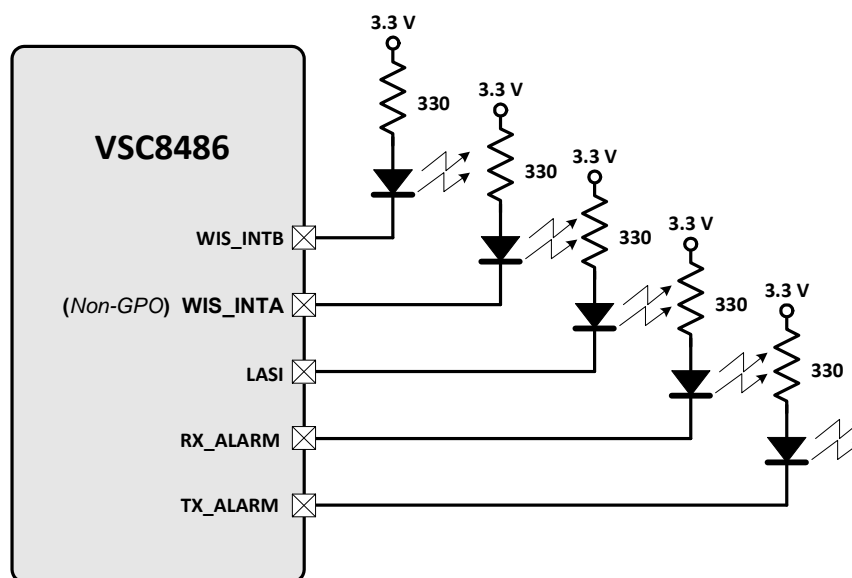
**Table 39 • XFP or SFP+ Host Application Pin Connections Summary (continued)**

VSC8486-04 Pin	I/O	Default Operation	XFP Host Operation	SFP+ Host Operation	Comments
TX_ALARM	Open-drain output	Global SERDES transmit channel fault	TX_DIS	Not used with SFP+	For XFP, configure as GPO using 1×E901.14:13 set to 10 (default is 00) and then use 1×E901.8 set to force.
STWSCL	Open-drain output	Two-wire serial clock source	SCL	SCL	Two-wire serial interface clock. See 1×E900.3:0.
STWSDA	Bidirectional open-drain output	Two-wire serial bidirectional data line	SDA	SDA	Two-wire serial interface data line. See 1×E900.3:0.
TXDOUTP/N	CML diff pair output	XFI Tx	TD+/-	TD+/-	10-gigabit serial data from the VSC8486-04 to the XFP or SFP+ module.
REFCLKAP/N	CML diff pair output	Div/64 reference clock to XFP	REFCLKP/N	REFCLKP/N	For XFP, CLK64AP/N (CMU/64) enabled by default. Disable using CLK64A_EN or register 1×E602.9.
RXINP/N	CML diff pair output	XFI Rx	RD+/-	RD+/-	10-gigabit serial data to the VSC8486-04 from the XFP or SFP+ module.
WIS_INTA	Open-drain output	Selectable WIS interrupt output	Output to CPU	Output to CPU	Global XFP or SFP+ alarm interrupt signal to CPU.

1. With the MSTCODE[2:0] pins utilized for XFP or SFP+ operation, the two-wire serial interface can still be used in high-speed mode. To accomplish this, assert register bit 1×E900.3 to set the master code from registers 1×E900.2:0 instead of from the MSTCODE[2:0] pins.

### 3.11.1 General Purpose and LED Driver Outputs

The VSC8486-04 includes several output pins that are capable of directly driving light emitting diodes (LEDs) and are programmable through MDIO. These outputs use open drain configuration and require pull-up resistors as shown in the following diagram.

**Figure 55 • Interrupt/Status/Activity LED Connections**

The following table includes configuration options for the general purpose output (GPO) pins. Registers 1×E900, 1×E901, and 1×E902 are used to program the GPO function.

**Table 40 • GPO Configuration Control Summary**

Pin Name	Source Select	GPO Mode Output Control	Other Controls
WIS_INTB (L6)	1×E901.9 0: XFP module reset or SFP+ TXDISABLE (default) 1: WIS interrupt B function	If WIS interrupt B enabled (1×E901.9 = 1), then 1×E607.2 displays WIS_INTB pin status.	WIS_INTB_POL (1×E605.15). EWIS_MASKB_1 (2×EF02). EWIS_INTR_MASKB2 (2×EF06).
LASI (E5)	1×E901.10 0: Normal LASI output (default) 1: GPO mode	If GPO mode is active (1×E901.10 = 1), then bit 1×E901.6 is transmitted to LASI.	LASI output is disabled by default and enabled using 1E×9002.0 (reference is Xepak 3.0).
RX_ALARM (C4)	1×E901.12:11 00: Normal RX_ALARM (default) 01: Rx link/activity LED 10: GPO mode 11: Reserved	If GPO mode is active (1×E901.12:11 = 10), then bit GPO_RXALARM (1×E901.7) is transmitted to RX_ALARM.	RX_ALARM is clear on read by default and controlled using 1E×9003 (reference is Xepak 3.0). Other controls: Rx LED mode control (1×E901.1:0) and Rx data activity LED blink time (1×E901.4).
TX_ALARM (E4)	1×E901.14:13 00: Normal TX_ALARM (default) 01: Tx Link/Activity mode 10: GPO mode 11: Reserved	If GPO mode is active (1×E901.14:13 = 10), then bit GPO_TXALARM (1×E901.8) is transmitted to TX_ALARM.	TX_ALARM is clear on read by default and controlled using 1E×9004 (reference is Xepak 3.0). Other controls: Tx LED mode control (1×E901.3:2) and Tx data activity LED blink time (1×E901.5).

When the RX\_ALARM output is programmed to Rx Link/Activity mode, an external LED responds as follows: Rx Activity Status indicates receipt of ||S|| characters, and Rx Link Status indicates PCS block lock = 1. (LED is on during block lock.)

The Combination Rx Link/Activity Status mode (1×E901.12:11 = 01) indicates the following:

- LED is off – Rx Link is down
- LED is on steady – Rx Link is up, but no ||S|| characters received
- LED blinking – Link is up and receiving ||S|| characters (steady state blink with off time set to approximately 100 milliseconds)

When the TX\_ALARM output is programmed to Tx Link/Activity mode, an external LED responds as follows: Tx Activity Status indicates transmission of ||S|| characters, and Tx Link Status indicates XAUI Lanes is aligned or is transmitting ||S|| characters when the transmitted traffic source is XGMII.

The Combination Tx Link/Activity Status mode (1×E901.14:13 = 01) indicates the following:

- LED is off – Tx Link is down
- LED is on steady – Tx Link is up, but no ||S|| characters transmitted
- LED blinking – Tx Link is up and transmitting ||S|| characters (steady state blink with off time set to approximately 100 milliseconds)

Both Rx and Tx combination link/activity status outputs initially hold the LED on for up to 5 seconds, even if data activity begins in less time. If the link is down, the LED is off, regardless of elapsed time.

**Note:** The link/activity status outputs work for PCS mode and E-PCS mode.

## 3.12 JTAG Access Port

A JTAG access port is provided on the VSC8486-04 transceiver to facilitate device level and board-level testing. All pins except the 3-Gbps and 10-Gbps serial I/O pins and some analog pins can be accessed

or controlled through this port. This port is compliant with IEEE Standard 1149.1-2001 (subsequently referred to as the JTAG specification) with the five control TTL signals listed in the following table.

**Table 41 • JTAG TTL Signals**

Signal	Description
TCK	Test clock input
TMS	Test mode select input
TDI	Test data input
TDO	Test data output
TRSTB	Test reset input

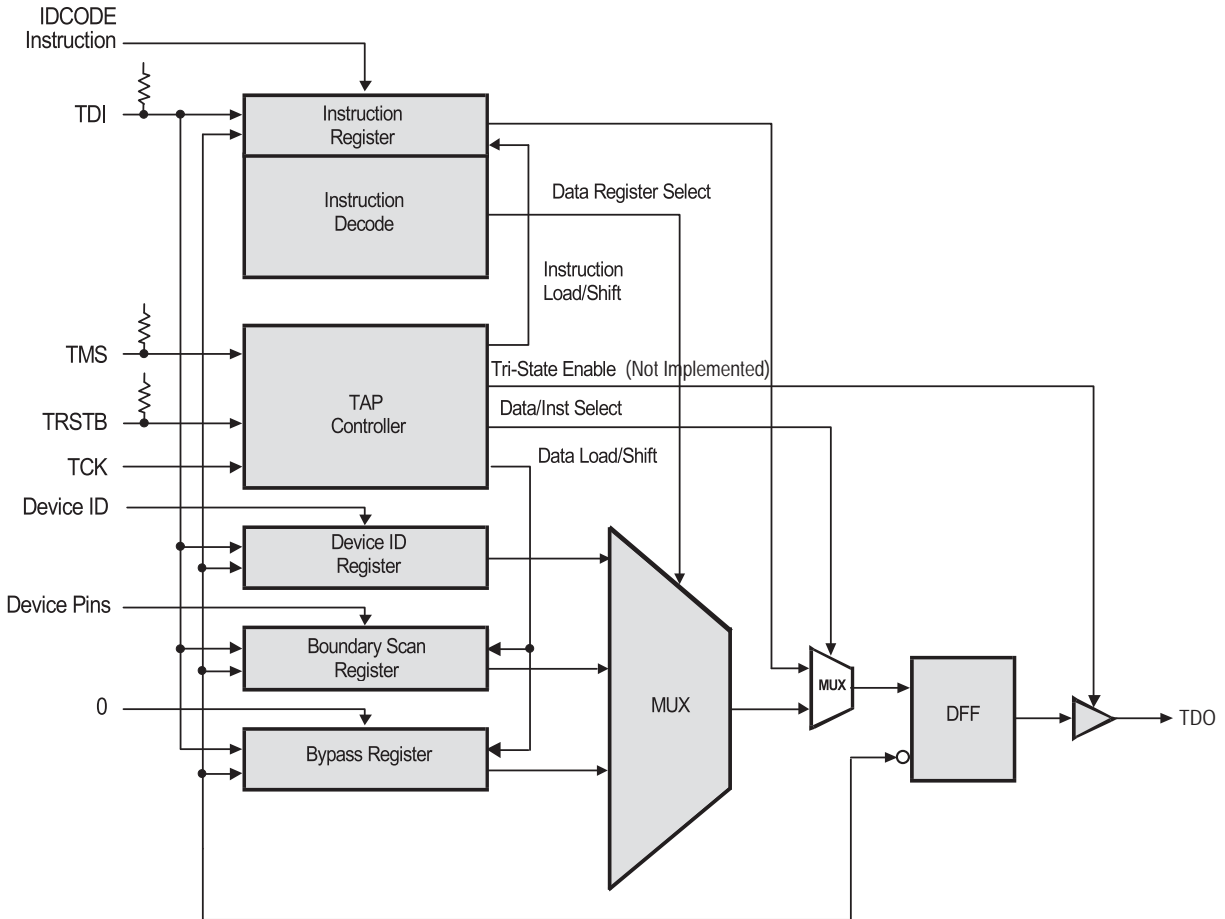
These signals control the Test Access Port (TAP) and associated circuitry to enable boundary and internal scan testing operations.

To ensure reliability, a TRSTB input (instead of a power-on reset circuit) is provided to initialize the JTAG logic. This input, TRST\* in the JTAG specification, is asserted when in the low (logic 0) state. The TRSTB, TDI, and TMS input pins have an on-chip, high-impedance, pull-up resistor connected to the VDDTTL supply so that an un-driven input behaves as though a logic 1 were applied. Because the TAP controller is reset from the TRSTB signal and not a power-on reset circuit, the TAP controller, without a reset, can come up in an indeterminate state, thereby affecting the mode of inputs and outputs. It is imperative that users ensure that the TAP controller is reset prior to normal operation. This can be achieved by tying TRSTB low (logic 0) if JTAG is undesired or ensuring the pull-down is strong enough to overcome the internal pull-up resistor, yet weak enough that the JTAG exerciser can overcome the pull-down.

Boundary scan and internal scan testing is supported through the JTAG standard TAP and associated circuitry. This circuitry consists of a TAP controller, an instruction register with decoder, and four data registers, including a device ID register, a boundary scan register, a bypass register and the internal scan chain register. In general, these data registers consist of two parts: a serial shift register and a parallel output (or shadow) register. The parallel output registers maintain their values during shift operations and are loaded with new values from the shift register during an update state. The following illustration shows the architecture of the boundary scan test circuitry.

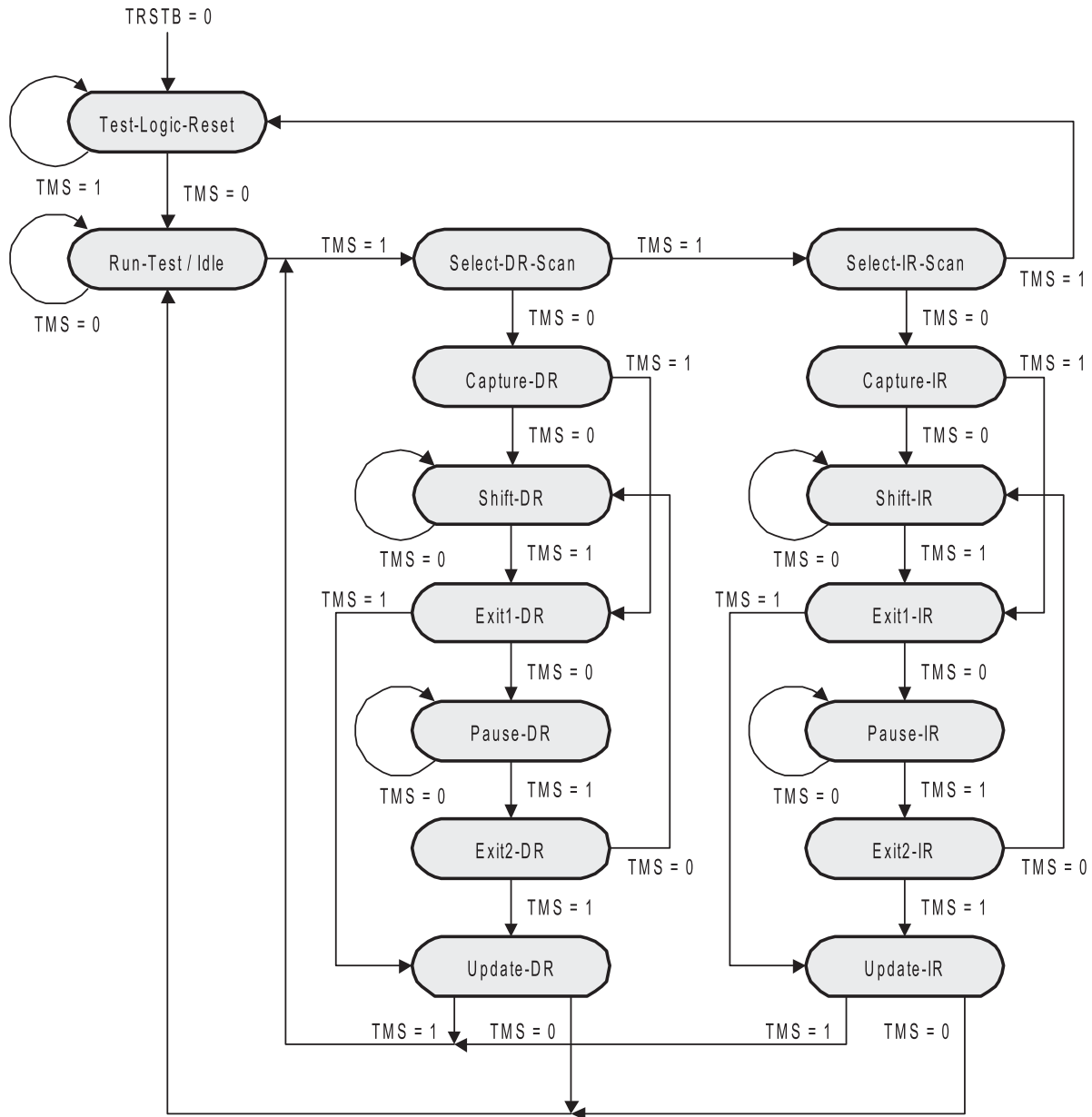


**Figure 56 • JTAG TAP Boundary Scan Test Architecture**



The TAP controller is a synchronous state machine that captures and shifts test data through the test registers. State transitions occur on the rising edge of TCK and are controlled by the TMS signal as illustrated in the following illustration.

**Figure 57 • TAP Controller State Diagram**



The following table describes the TAP Controller states.

**Table 42 • TAP Controller States**

TAP Controller State	Description
Test-Logic-Reset	Activating TRSTB forces the TAP Controller to asynchronously enter the Test-Logic-Reset state. This state is also entered synchronously within five TCK cycles if TMS is held high. In Test-Logic-Reset state all of the associated test logic is reset and disabled, allowing the device to operate normally. The Instruction register is loaded with the IDCODE instruction while the data registers are reset to logic 0.

**Table 42 • TAP Controller States (continued)**

<b>TAP Controller State</b>	<b>Description</b>
Run-Test/Idle	Run-Test/Idle state is an idle state in which the test logic is disabled and the device operates normally. It is different than the Test-Logic-Reset state in that the current state of the test logic is maintained.
Select-DR-Scan, Select-IR-Scan	These states are single TCK states that allow the selection of data register scan operations or Instruction register scan operations.
Capture-DR	Capture-DR state causes the selected serial data register to be loaded in parallel with a data value determined by the current instruction. The data is loaded on the rising edge of TCK as the TAP Controller transitions to the next state.
Shift-DR	Shift-DR state causes the selected data register to shift one bit in the direction going from TDI (MSB) towards TDO (LSB). Repeated single-bit shifts are performed on each rising TCK edge that TMS is held low.
Exit1-DR, Exit2-DR	These states are single TCK states at the end of a data register shift that allow a return to the Shift-DR state without going through the Capture-DR state, or allow the state machine to exit the data register shifting process back to the idle condition. TDO transitions to the high-impedance state on the first falling edge of TCK after the Exit1-DR state is entered.
Pause-DR	Pause-DR state allows the data register shifting process to be suspended without change or loss of the data register contents.
Update-DR	Update-DR state causes the parallel output (shadow) register part of the selected data register to be updated to match the value currently stored in the serial data register part. This update occurs on the first falling edge of TCK after the Update-DR state is entered. (Currently only the boundary scan register has parallel output registers.)
Capture-IR	Capture-IR state causes the Instruction register serial part to be loaded in parallel with status information. The status is loaded on the rising edge of TCK as the TAP Controller transitions to the next state. (Currently the status information is simply the IDCODE instruction.)
Shift-IR	Shift-IR state causes the Instruction register to shift one bit in the direction going from TDI (MSB) towards TDO (LSB). Repeated single-bit shifts are performed on each rising TCK edge that TMS is held low.
Exit1-IR, Exit2-IR	These states are single TCK states at the end of an Instruction register shift that allow a return to the Shift-IR state without going through the Capture-IR state, or allow the state machine to exit the Instruction register shifting process back to the idle condition. TDO transitions to the high-impedance state on the first falling edge of TCK after the Exit1-IR state is entered.
Pause-IR	Pause-IR state allows the Instruction register shifting process to be suspended without change or loss of the Instruction register contents.
Update-IR	Update-IR state causes the instruction currently loaded into the serial shift register part of the Instruction register to be loaded into the parallel output (shadow) register part of the Instruction register. This causes the instruction to become active. This activation of the instruction occurs on the first falling edge of TCK after the Update-IR state is entered.

### 3.12.1 Instruction Register

The four-bit Instruction register and associated decode circuitry determine the operation performed by the scan test logic, and which data register is selected in the scan path for the operation. In the Test-

Logic-Reset state, the Instruction register is initialized to the IDCODE instruction. The Instruction register is then loaded with status information during the Capture-IR state, in which the two least-significant bits must be 01 for scan-path testing purposes (currently the status information is the IDCODE instruction). Serially-loaded instructions become active at the Update-IR state.

The following table lists supported test instructions, including the data register selected for each test, plus the device-operating mode during the selected test. When the device is in test mode, the output pins are affected by the test operation. In normal mode, device inputs, outputs and internal logic are unaffected by the test operation.

**Table 43 • Supported Boundary Scan Test Instructions**

Instruction Code	Instruction	Selected Data Register	Device Operating Mode
0000	EXTEST	Boundary Scan	Test
0001	IDCODE	Device ID	Normal
0010	SAMPLE/PRELOA D	Boundary Scan	Normal
1111	BYPASS	Bypass	Normal
All others	Invalid	Unknown	Unknown

The following table provides a description of each supported test instruction.

**Table 44 • Boundary Scan Test Instruction Descriptions**

Instruction	Description
EXTEST	The EXTEST instruction enables board-level interconnect testing and device I/O level testing by allowing device inputs to be observed and controlled. The device inputs are captured during the Capture-DR state and subsequently shifted out on TDO with the Shift-DR state. Device outputs can be set by providing the desired values on TDI during the Shift-DR state, and then driving the outputs with the loaded values at the Update-DR state.
IDCODE	The IDCODE instruction enables the Device ID register to be read by serially-shifting bit values out on TDO with the Shift-DR state. This instruction is automatically loaded by entering the Test-Logic-Reset state in addition to the normal serial instruction loading mechanism.
SAMPLE/ PRELOAD	The SAMPLE/PRELOAD instruction enables observation of device inputs and internal output signals while the normal operation. The signal values are loaded into the boundary scan register during the Capture-DR state and observed by shifting the values out with the Shift-DR state. The pre-load aspect of this instruction occurs at the Update-DR state, when values in the serial part of the boundary scan register are loaded into the parallel output (shadow) part. This allows the boundary scan register to be pre-loaded for subsequent test operations such as EXTEST or CLAMP.
BYPASS	The BYPASS instruction allows serial data on TDI to be transferred to TDO with only one TCK delay. This facilitates board-level testing by allowing the serial test data to quickly pass on to the next device. The bypass register is loaded with a logic 0 during the Capture-DR state.

### 3.12.2 Device ID Register

The 32-bit device ID register is used to identify the manufacturer, part number, and version of the device through the JTAG test access port. When the IDCODE instruction is loaded, this identification data is loaded into the Device ID shift register during the Capture-DR state, and can be shifted out on TDO through the use of the Shift-DR state. The following table includes a description of the device identification information.

**Note:** The version number depicted does not necessarily reflect the latest revision of the VSC8486-04 device.

**Table 45 • Device Identification Information**

Type	Version Number	Part Number	Manufacturer ID	Fixed
Register bits	[31...28]	[27...12]	[11...1]	0
Hex value	0×2	0×8486	0×074	2

### 3.12.3 Bypass Register

The single-bit Bypass register enables system serial test data to bypass the device with only one TCK cycle delay. This register is used in the scan path during the BYPASS instruction. This register is set to logic 0 during the Capture-DR state.

### 3.12.4 Boundary Scan Register

The 127-bit Boundary Scan register (BSR) provides the means to force values on the device outputs and to capture values on the device inputs (and internal output signals). The direction of shift is from TDI (MSB), through bits 1-127, to TDO (LSB). The BSR bits and their associated device signals are summarized in the following table. A full Boundary Scan Description Language (BSDL) file is available upon request.

**Table 46 • Boundary Scan Register Bits**

BSR Bit	Device Signal	BSR Cell Type	BSR Bit	Device Signal	BSR Cell Type
0	RXALARM	OUT	39	TXD[29]	IN
1	TXALARM	OUT	40	TXD[30]	IN
2	LASI	OUT	41	TXD[31]	IN
3	REFSEL1	IN	42	TXC[3]	IN
4	REFSEL0	IN	43	PMTICK	IN
5	SPLITLOOPN	IN	44	TXONOFFI	IN
6	TXD[0]	IN	45	WIS_INTA	OUT
7	TXD[1]	IN	46	LP_16B	IN
8	TXD[2]	IN	47	LP_XGMII	IN
9	TXD[3]	IN	48	FORCE_AIS	IN
10	TXD[4]	IN	49	WANMODE	IN
11	TXD[5]	IN	50	LPP_10B	IN
12	TXD[6]	IN	51	RFPOUT	OUT
13	TXD[7]	IN	52	LP_XAUI	IN
14	TXC[0]	IN	53	CLK64A_EN	IN
15	TXD[8]	IN	54	LOPC	IN
16	TXD[9]	IN	55	RCLKOUT	OUT
17	TXD[10]	IN	56	RDAOUT	OUT

**Table 46 • Boundary Scan Register Bits (continued)**

BSR Bit	Device Signal	BSR Cell Type	BSR Bit	Device Signal	BSR Cell Type
18	TXD[11]	IN	57	TCLKOUT	OUT
19	TXC[1]	IN	58	TDAIN	IN
20	TXD[13]	IN	59	XTX0	Linkage bit
21	TXD[14]	IN	60	XTX1	Linkage bit
22	TXD[15]	IN	61	XTX2	Linkage bit
23	TXD[12]	IN	62	XTX3	Linkage bit
24	TXCLK	IN	63	XR3	Linkage bit
25	TXD[16]	IN	64	XR2	Linkage bit
26	TXD[17]	IN	65	XR1	Linkage bit
27	TXD[18]	IN	66	XR0	Linkage bit
28	TXD[19]	IN	67	IOMODESEL	IN
29	TXD[20]	IN	68	TFPOUT	OUT
30	TXD[21]	IN	69	MSTCODE[0]	IN
31	TXD[22]	IN	70	EPCS	IN
32	TXC[2]	IN	71	MSTCODE[1]	IN
33	TXD[23]	IN	72	AUTONEG	IN
34	TXD[24]	IN	73	STWWP	IN
35	TXD[25]	IN	74	MSTCODE[2]	IN
36	TXD[26]	IN	75	PRTAD[0]	IN
37	TXD[27]	IN	76	PRTAD[1]	IN
38	TXD[28]	IN	77	PRTAD[2]	IN
78	PRTAD[3]	IN	119	MDC	IN
79	PRTAD[4]	IN	120	STWSCL	IN
80	MDIO	IN	121	STWSCL	OUT
81	MDIO	OUT	122	STWSDA	IN
82	RXC[3]	OUT	123	STWSDA	OUT
83	RXD[31]	OUT	124	WIS_INTB	OUT
84	RXD[30]	OUT	125	RESETN	IN
85	RXD[29]	OUT	126	RXINOFFN	IN
86	RXD[28]	OUT			
87	RXD[27]	OUT			
88	RXD[26]	OUT			
89	RXD[25]	OUT			
90	RXD[24]	OUT			
91	RXC[2]	OUT			
92	RXD[23]	OUT			
93	RXD[22]	OUT			
94	RXD[21]	OUT			

**Table 46 • Boundary Scan Register Bits (continued)**

BSR Bit	Device Signal	BSR Cell Type	BSR Bit	Device Signal	BSR Cell Type
95	RXD[20]	OUT			
96	RXD[19]	OUT			
97	RXD[18]	OUT			
98	RXD[17]	OUT			
99	RXD[16]	OUT			
100	RXCLK	OUT			
101	RXD[13]	OUT			
102	RXD[15]	OUT			
103	RXD[14]	OUT			
104	RXC[1]	OUT			
105	RXD[12]	OUT			
106	RXD[11]	OUT			
107	RXD[10]	OUT			
108	RXD[9]	OUT			
109	RXD[6]	OUT			
110	RXC[0]	OUT			
111	RXD[7]	OUT			
112	RXD[8]	OUT			
113	RXD[5]	OUT			
114	RXD[4]	OUT			
115	RXD[3]	OUT			
116	RXD[2]	OUT			
117	RXD[1]	OUT			
118	RXD[0]	OUT			

### 3.13 Synchronous Ethernet

The VSC8486-04 device supports two modes for Synchronous Ethernet implementation: conventional mode and enhanced mode. The conventional mode requires either a REFCLK from an external narrow-banded PLL, which provides a 156.25 MHz clock  $\pm 200$  ppm even without any input to lock onto, or a REFCLK from an external oscillator to hold in its place until a clean recovered clock is available.

The enhanced mode eliminates this transient period or clock switching by providing separate clock sources for the PMA's CMU and CRU. An external PLL is required for jitter clean up. This section presents the differences between the conventional and enhanced modes.

#### 3.13.1 About Conventional Mode

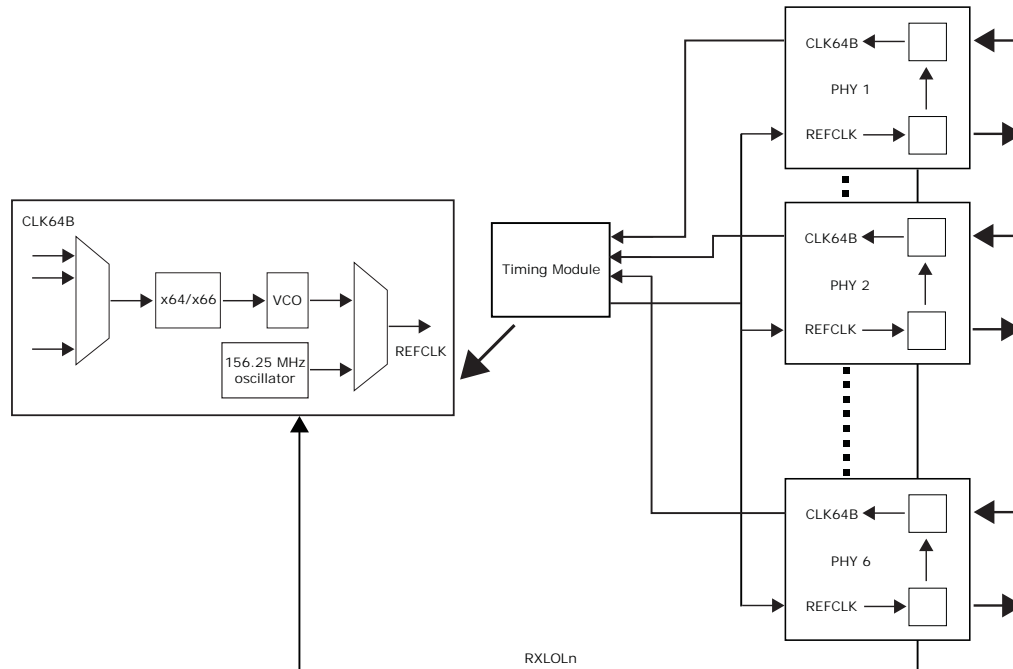
For Synchronous Ethernet application in conventional mode, the recovered clock from the XFI input data is used to generate the REFCLK for the transmitter of all PHYs and in turn the REFCLK is needed to recover the clock. Because the REFCLK and recovered clock are needed and are dependent on each other, the conventional method for Synchronous Ethernet configuration is to provide the REFCLK from an external narrow-banded PLL so that the PLL output is within 100 ppm of the required 156.25 MHz, even if there is no input at the PLL for the PLL to lock onto. When the recovered clock is available from the VSC8486-04 device, the PLL will lock onto the recovered clock to achieve synchronization between the Tx clock and the Rx clock of the PHY.

Another alternative is to start with an oscillator to generate the required 156.25 MHz and then switch to a recovered clock (with clean jitter and adjusted frequency) when available.

A typical overview of how to perform synchronization of the CMU transmit clock to the CRU recovered clock are as follows:

- Recover the clock from the XFI input in each line card
- Indicate the strength of the recovered clock signal
- Select the recovered clock from the different line cards
- Translate the recovered clock frequency to the reference clock frequency
- Clean up the jitter of the recovered clock
- Distribute the recovered clock as the transmit clock to all PHYs

**Figure 58 • Clock Path Distribution, Conventional Mode**



Note: Each PHY is the line card provides a signal to the timing module.

### 3.13.2 Using Conventional Mode

Use the following recommended procedure for Synchronous Ethernet in conventional mode.

Set register bit 1×E602.5 to high to enable the CLK64B output and set register bits 1×E602.4:3 to 00. These settings enable the CLK64b output and programs the output as a divide-by-64 recovery clock from the XFI input.

1. Before the recovered clock of a particular line card is selected as the REFCLK, complete one of the two steps to notify the timing module that the recovered clock is stabilized and valid for use:
  - Read the Receiver Loss of Lock signal from register bit 2×EF03.12.

or

  - Configure the WIS\_INTA/B as the LOL indicator by using register bits 2×EF05.12 (WIS\_INTA) or 2×EF06.12 (WIS\_INTB).
2. Select the corresponding CLK64B output to use as a reference clock when the RXLOL indicates a valid signal from the VSC8486-04 device.
3. Multiply the CLK64B output by 64 and then divide-by-66 to obtain the required 156.25 MHz clock.

REFCLK is used for the transmit clock for the CMU and the hint clock for the CRU inside the



VSC8486-04 device. Due to the 156.25 MHz frequency in LAN mode and the 161 MHz frequency of the CLK64B output, this step is required to obtain the necessary 156.25 MHz clock.

4. Provide an external PLL to clean the recovered clock jitter of the VSC8486-04 device.

External PLL allows the REFCLK to use the recovered clock jitter to meet the jitter generation specifications of the XFI. All line cards can now use the clean output clock from the PLL as the REFCLK, which in turn can be used as the Tx clock of the CMU on each PHY. Therefore, the clock that is synchronized to the input data of the selected line card, will be distributed and propagated to other systems.

When using this procedure for Synchronous Ethernet implementation, one consideration is that the REFCLK is needed as the hint clock for the CRU of the PHY and the recovered clock from the CRU is used for the REFCLK for all the line cards including the same PHY. To resolve this dependency, a clock source such as an oscillator is used at start up as the REFCLK to allow the CRU to recover the clock from the XFI input data. Once the recovered clock is available, the external PLL will lock to it and clean up the jitter to provide the REFCLK. The clock source is then switched from the oscillator to this PLL output. The output of the PLL and oscillator must be within 100 ppm to provide an acceptable transient environment.

Another method to resolve this dependency is to use a narrow band PLL that will output 156.25 MHz  $\pm$  100 ppm even if there is no input to the PLL for it to lock on to. When an input is available to lock on, the output of the PLL is frequency locked to the input. Additionally, some PLLs can accept an input of 161 MHz or 156.25 MHz to generate the required 156.25 MHz REFCLK which resolves the frequency matching issue between the CLK64B and the REFCLK.

### 3.13.3 About Enhanced Mode

The VSC8486-04 device is designed with enhancements that allows for a simplified start up synchronization process that eliminates the need for an external narrow banded PLL and transient period of switching clocks.

This section describes the enhancements that simplify the synchronization process.

#### Reference Clock Source Signals

Separate reference clock source signals are provided for the PMA's CMU, CRU, and for XAUI operation. The following table provides the reference clock source signals and recommendations for Synchronous Ethernet application.

**Table 47 • Synchronous Ethernet Reference Clock Source**

CRU/CMU/Block	Reference Clock Source	Synchronous Ethernet (Recommended)
CRU of PMA	REFCLK, WREFCLK, and VREFCLK	REFCLK
CMU of PMA	REFCLK, WREFCLK, VREFCLK, and internal recovered clock	REFCLK
XAUI block	REFCLK only	REFCLK only

#### 3.13.3.1 MUXs and Register Bits

Additional MUXs and register bits were added to provide additional flexibility in controlling the clock sources to the different blocks of the VSC8486-04 device for Synchronous Ethernet implementation. When 1xE602.2 is high, the register 1xE604.7:0 should be set to one of the following:

10011001: REFCLK = 156.25 MHz, VREFCLK = 161.1328125 MHz.

10011011: REFCLK = 156.25 MHz, VREFCLK = 644.53125 MHz.

10011101: REFCLK = 156.25 MHz, VREFCLK = 156.25 MHz.

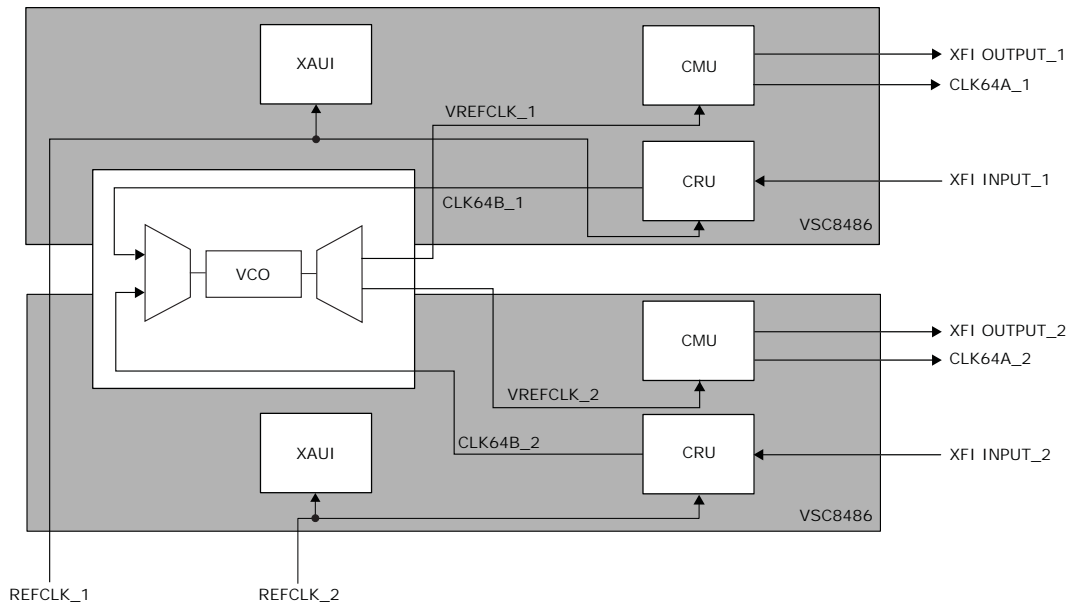
The following table lists the added register bits and descriptions for the VSC8486-04 device.

**Table 48 • Synchronous Ethernet Register Bits**

Register	Bit	Description
1×E602	2	Clock mode override. When this bit is enabled, register 1×E604 can be used to program the clock sources used by the CMU and CRU. 0: Disables the mode override (default). 1: Enables the mode override.
1×E604	7	Clock source for CMU linetime mode when register 1×E602.2 = 1 and linetime mode = 1. 0: Reserved. 1: CMU clock is from the CRU recovered clock. Divided by 64.
	6:5	Clock source to CRU when 1×E602.2 = 2. 00: CRU source clock is from REFCLK. 01: Clock source to CRU is from WREFCLK input. Divided by 64. 1×: Clock source to CRU is from WREFCLK input. Divided by 16.
	4:3	Clock source to CMU when 1×E602.2 = 1. 00: Reserved. 01: Clock source to CMU is from REFCLK input. 10: Clock source to CMU is from internal CRU recovered clock. 11: Clock source to CMU is from VREFCLK input.
	2:1	Provides selection of clock ratio for CMU when register 1×E602.2 = 1. 00: Divided by 64. Only valid when 1×E604.4:3 = 01, 10, 11. 01: Divided by 16. Only valid when 1×E604.4:3 = 01, 10, 11. 1×: Divided by 66. Only valid when 1×E604.4:3 = 00, 01, 10.
	0	Provides selection of clock ratio for CRU when 1×E602.2 = 1. 0: Divided by 64. Only valid when 1×E604.6:5 = 01, 1×. 1: Divided by 66. Only valid when 1×E604.6:5 = 00.

A significant benefit of using Synchronous Ethernet in enhanced mode is the ability to eliminate the transient period that occurs in conventional mode because the REFCLK is needed to recover the clock from the input data. WREFCLK and VREFCLK can be divided-by 16, 64, or 66, whereas the REFCLK can only be divided-by 66. For improved jitter performance in WAN applications, the VREFCLK divided-by 16 is preferred. The recovered CLK64B could be set to a PLL that takes in the CLK64B and provides a 4× CLK64B. A narrow band PLL would no longer be required and the need to adjust a /66 REFCLK from a /64 recovered clock is eliminated. The REFCLK and WREFCLK if needed, can be used as free running clocks from oscillators full time. These features provide a more effective implementation using a common PLL.

Using the REFCLK for both the XAUI block and the clock source for the PMA's CRU, while leaving the WREFCLK unused, provides for a more cost effective solution. The VREFCLK can be selected to be at the same frequency as the CLK64B, for example 161 MHz. A 1:1 PLL is still required to clean up the jitter from CLK64B to the VREFCLK input block. A free running clock source is needed for the PMA's CRU through the REFCLK.

**Figure 59 • Synchronous Ethernet Block Diagram**


### 3.13.4 Using Enhanced Mode

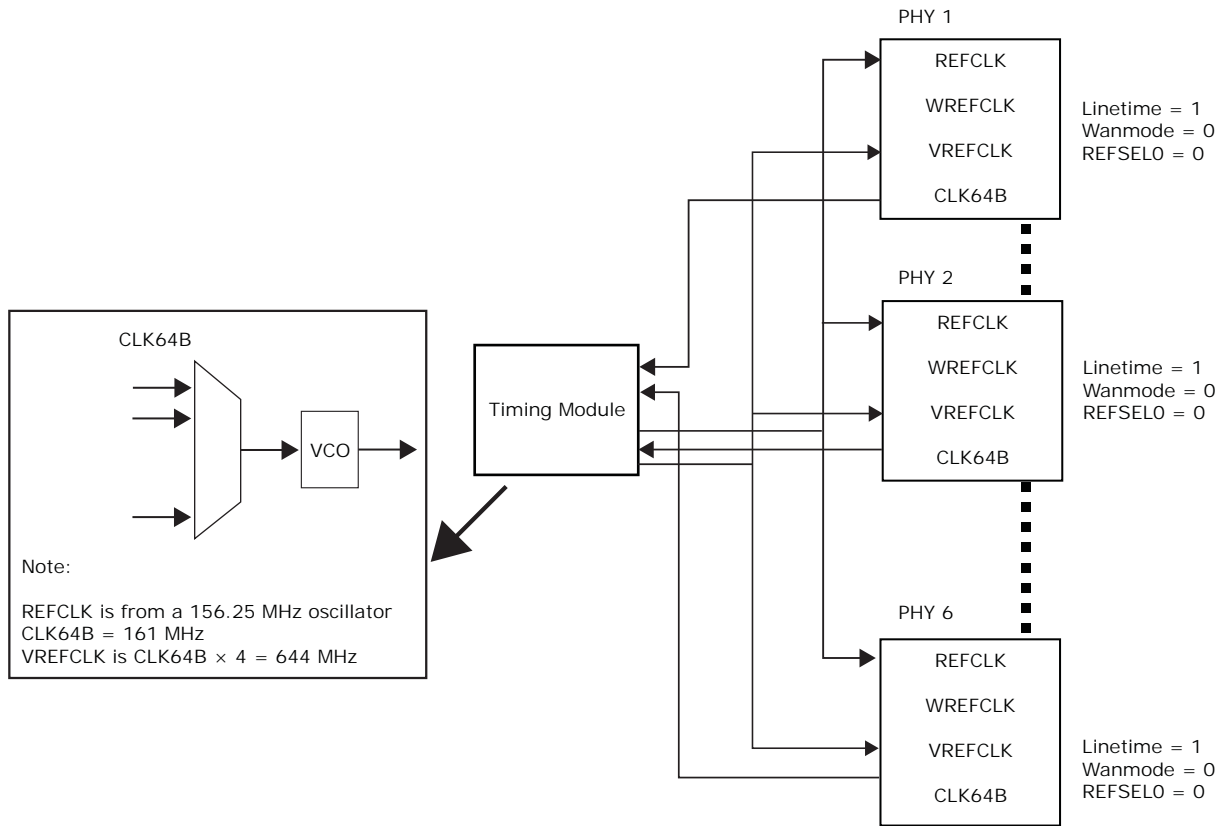
The additional MUX register bits and separate clocks that are provided in the VSC8486-04 device lead to the distribution of clock paths and simplifies the start up synchronization process for Synchronous Ethernet operation.

Use the following recommended procedure for Synchronous Ethernet in enhanced mode.

1. Set registers  $1 \times E602.2 = 1$ ,  $1 \times E604.6:5 = 0$ , and  $1 \times E604.0 = 1$ . These settings configure a free running oscillator based clock at 156.25 MHz which in turn is used for the XAUI block and the hint clock of the CRU to recover the CLK64B from the XFI input data.
2. Set register bit  $1 \times E602.5$  to high to enable the CLK64B output and set register bits  $1 \times E602.4:3$  to 00. These settings enable the CLK64b output and programs the output as a divide-by-64 recovery clock from the rate of the XFI input.
3. Before the recovered clock of a particular line card is selected as the REFCLK, complete one of the two steps to notify the timing module that the recovered clock is stabilized and valid for use:
  - Read the Receiver Loss of Lock signal from register bit  $2 \times EF03.12$ .
 or
  - Configure the WIS\_INTA/B as the LOL indicator by using register bits  $2 \times EF05.12$  (WIS\_INTA) or  $2 \times EF06.12$  (WIS\_INTB).
4. Select the corresponding CLK64B output to use as a reference clock when the RXLOL indicates a valid signal from the VSC8486-04 device.
5. Set register bits  $1 \times E604.4:3 = 10$  and  $1 \times E604.2:1 = 01$ . These register settings require a 644 MHz clock which needs to be derived from the CLK64B and requires low jitter.

The PLL output is phase locked to the CLK64B and is distributed to the device on all line cards, which in turn is the VREFCLK that is the transmit clock of the CMU on each PHY. Therefore, the clock that is synchronized to the input data of the selected line card is distributed and propagated to other systems. A free running REFCLK of 156.25 MHz is required for the PHYs.

**Figure 60 • Clock Path Distribution, Enhanced Mode**



## 4 Registers

This section describes the registers for the VSC8486-04 device. The registers marked reserved and factory test should not be read or written to, because doing so may produce undesired effects.

The default value documented for registers is based on the value at reset; however, in some cases, that value may change immediately after reset.

The access type for each register is shown using the following abbreviations:

- RO: Read Only
- ROCR: Read Only, Clear on Read
- RO/LH: Read Only, Latch High
- RO/LL: Read Only, Latch Low
- RW: Read and Write
- RWSC: Read Write Self Clearing

The registers are organized into the following sections:

- [Device 1: PMA Registers](#), page 96
- [Device 2: WIS Registers](#), page 115
- [Device 3: PCS Registers](#), page 153
- [Device 4: PHY-XS Registers](#), page 166
- [Device 30: NVR and DOM Registers](#), page 179

### 4.1 Device 1: PMA Registers

The following tables provide settings for the registers related to the PMA.

**Table 49 • PMA\_CTRL1: PMA Control 1 (1×0000)**

Bit	Name	Access	Description	Default
15	SOFT_RST	RWSC	Reset all MMDs. 0: Normal operation. 1: Reset.	0
14	Reserved	RO	Reserved (value always 0, writes ignored).	0
13	SPEED_SEL_A	RO	Indicates whether the device operates at 10 Gbps and above. 0: Unspecified. 1: Operates at 10 Gbps and above.	1
12	Reserved	RO	Reserved (value always 0, writes ignored).	0
11	LOW_PWR	RW	PMA low power mode control. 0: Normal. 1: Low power mode. TXEN is cleared low and everything except MDIO, SPI, and reference clock receiver is disabled.	0
10:7	Reserved	RO	Reserved (value always 0, writes ignored).	0
6	SPEED_SEL_B	RO	Indicates whether the device operates at 10 Gbps and above. 0: Unspecified. 1: Operation at 10 Gbps and above.	1

**Table 49 • PMA\_CTRL1: PMA Control 1 (1×0000) (continued)**

Bit	Name	Access	Description	Default
5:2	SPEED_SEL_C	RO	Speed selection. 1xx: Reserved x1xx: Reserved xx1x: Reserved 0001: Reserved. 0000: 10 Gbps.	0
1	Reserved	RO	Reserved (value always 0, writes ignored).	0
0	LPBK_J_PMA	RW	PMA/WIS system loopback J. 0: Disable. 1: Enable. All zeros output on XFI.	0

**Table 50 • PMA\_STAT1: PMA Status 1 (1×0001)**

Bit	Name	Access	Description	Default
15:8	Reserved	RO	Reserved (ignore when read).	0
7	FAULT	RO	Indicates a fault condition on either the transmit or receive paths. 0: Fault condition not detected. PMA receive local fault (1×0008.10) = 0 and PMA transmit local fault (1×0008.11) = 0. <b>Note:</b> 1: Fault condition detected. PMA receive local fault (1×0008.10) = 1 or PMA transmit local fault (1×0008.11) = 1.	0
6:3	Reserved	RO	Reserved (ignore when read).	0
2	LNK_STAT	RO/LL	Receive link status. 0: PMA receive link down. (RXLOS = 1 and SUPPRESS_RXLOS = 0) or (RXLOCK = 0 and SUPPRESS_RXLOL = 0). 1: PMA receive link up. (RXLOS = 0 or SUPPRESS_RXLOS = 1) and (RXLOCK = 1 or SUPPRESS_RXLOL = 1).	1
1	LOW_PWR_ABILITY	RO	Indicates that MMD supports low power mode. 0: PMA does not support low power mode. 1: PMA supports low power mode.	1
0	Reserved	RO	Reserved (ignore when read).	0

**Table 51 • PMA\_DEVID1: PMA Device Identifier 1 (1×0002)**

Bit	Name	Access	Description	Default
15:0	DEV_ID_MSW	RO	Upper 16 bits of a 32-bit unique PMA device identifier. Bits 3-18 of the device manufacturer's OUI.	0×0007

**Table 52 • PMA\_DEVID2: PMA Device Identifier 2 (1×0003)**

Bit	Name	Access	Description	Default
15:0	DEV_ID_LSW	RO	Lower 16 bits of a 32-bit unique PMA device identifier. Bits 19-24 of the device manufacturer's OUI. Six-bit model number, and a four-bit revision number.	0×0400

**Table 53 • PMA\_SPEED: PMA Speed Capability (1×0004)**

Bit	Name	Access	Description	Default
15:1	Reserved	RO	Reserved for future speeds (value always 0, writes ignored)	0
0	RATE_ABILITY	RO	PMA rate capability 0: Not capable of 10 Gbps 1: Capable of 10 Gbps	1

**Table 54 • PMA\_DEVPKG1: PMA Devices in Package 1 (1×0005)**

Bit	Name	Access	Description	Default
15:6	Reserved	RO	Reserved (ignore when read)	0
5	DTE_XS_PRE	RO	Indicates whether DTE XS is present in the package 0: Not present 1: Present	0
4	PHY_XS_PRE	RO	Indicates whether PHY XS is present in the package 0: Not present 1: Present	1
3	PCS_PRE	RO	Indicates whether PCS is present in the package 0: Not present 1: Present	1
2	WIS_PRE	RO	Indicates whether WIS is present in the package 0: Not present 1: Present	1
1	PMD_PMA_PRES	RO	Indicates whether PMA is present in the package 0: Not present 1: Present	1
0	CLS22_PRE	RO	Indicates whether Clause 22 registers are present in the package 0: Not present 1: Present	0

**Table 55 • PMA\_DEVPKG2: PMA Devices in Package 2 (1×0006)**

Bit	Name	Access	Description	Default
15	VS2_PRES	RO	Vendor specific device 2 present 0: Not present 1: Present	0
14	VS1_PRES	RO	Vendor specific device 1 present 0: Not present 1: Present	0
13:0	Reserved	RO	Reserved (ignore when read)	0

**Table 56 • PMA\_CTRL2: PMA Control 2 (1×0007)**

Bit	Name	Access	Description	Default
15:3	Reserved	RO	Reserved.	0
2:0	PMA_MODE	RW	Indicates the PMA type selected 111: 10GBASE-SR 110: 10GBASE-LR 101: 10GBASE-ER 100: 10GBASE-LX-4 011: 10GBASE-SW 010: 10GBASE-LW 001: 10GBASE-EW 000: Reserved When these bits are set to 10GBASE-SW, 10GBASE-LW or 10GBASE-EW, the WAN mode is enabled.	0

**Table 57 • PMA\_STAT2: PMA Status 2 (1×0008)**

Bit	Name	Access	Description	Default
15:14	DEV_PRES	RO	Reflects the presence of a MMD responding at this address. 00: No device responding at this address. 01: No device responding at this address. 10: Device responding at this address. 11: No device responding at this address.	10
13	FAULT_TX_ABILITY	RO	Indicates a fault condition on the transmit path. 0: PMA does not have the ability to detect a fault condition on the transmit path. 1: PMA has the ability to detect a fault condition on the transmit path.	1
12	FAULT_RX_ABILITY	RO	Indicates a fault condition on the receive path. 1 0: PMA does not have the ability to detect a fault condition on the receive path. 1: PMA has the ability to detect a fault condition on the receive path.	1



**Table 57 • PMA\_STAT2: PMA Status 2 (1×0008) (continued)**

Bit	Name	Access	Description	Default
11	FAULT_TX	RO/LH	Indicates a fault condition on the transmit path. 0: No faults asserted. TXFAULT = 0 and TXLOCK = 1. 1: Fault asserted. TXFAULT = 1 or TXLOCK = 0. Linked to 1E×9004.4. A read to either 1×0008.11 or 1E×9004.4 clears both bits if the fault condition no longer exists.	0
10	FAULT_RX	RO/LH	Indicates a fault condition on the receive path. 0: No faults asserted. (RXLOS = 0 or SUPPRESS_RXLOS = 1) and (RXLOCK = 1 or SUPPRESS_RXLOL = 1). 1: Fault asserted. (RXLOS = 1 and SUPPRESS_RXLOS = 0) or (RXLOCK = 0 and SUPPRESS_RXLOL = 0). Linked to 1E×9003.4. A read to either 1×0008.10 or 1E×9003.4 clears both bits if the fault condition no longer exists.	0
9	Reserved	RO	Reserved (ignore when read).	0
8	TXDIS_ABILITY	RO	Device capability to disable the transmit path. 0: Not capable. 1: Capable. To disable PMD, use GPO_TXALARM (1×E901.8). Transmit output of the VSC8486-04 device is disabled by means of 1×0000.11 or 1×E605.9:8.	0
7	BASE_SR_ABILITY	RO	Device capability to support 10GBASE-SR. 0: Not capable. 1: Capable.	1
6	BASE_LR_ABILITY	RO	Device capability to support 10GBASE-LR. 0: Not capable. 1: Capable.	1
5	BASE_ER_ABILITY	RO	Device capability to support 10GBASE-ER. 0: Not capable. 1: Capable.	1
4	BASE_LX4_ABILITY	RO	Device capability to support 10GBASE-LX4. 0: Not capable. 1: Capable.	0
3	BASE_SW_ABILITY	RO	Device capability to support 10GBASE-SW. 0: Not capable. 1: Capable.	1
2	BASE_LW_ABILITY	RO	Device capability to support 10GBASE-LW. 0: Not capable. 1: Capable.	1
1	BASE_EW_ABILITY	RO	Device capability to support 10GBASE-EW. 0: Not capable. 1: Capable.	1

**Table 57 • PMA\_STAT2: PMA Status 2 (1×0008) (continued)**

Bit	Name	Access	Description	Default
0	PMA_LPBK_ABILIT Y	RO	Device capability to support a PMA loopback. 0: Not capable. 1: Capable.	1

**Table 58 • PMA\_CTRL3: PMA Control 3 (1×0009)**

Bit	Name	Access	Description	Default
15:5	Reserved	RO	Reserved (value always 0, writes ignored).	0
4:1	Reserved	RO	Reserved (value always 0, writes ignored).	0
0	TX_DIS	RW	Not supported. To disable the transmit output, use the low power mode (1×0000.11), external pin TXONOFFI, or the TXONOFFI override and force bits 1×E605.9:8. Additionally, the PMD transmitter output can be disabled by using the GPO_TXALARM (1×E901.8).	0

**Table 59 • PMA\_STAT3: PMA Status 3 (1×000A)**

Bit	Name	Access	Description	Default
15:5	Reserved	RO	Reserved (value always 0, writes ignored).	0
4:1	Reserved	RO	Reserved (value always 0, writes ignored).	0
0	RX_SD	RO	Receive signal detected. 0: Signal not detected. (RXLOS = 1 and SUPPRESS_RXLOS = 0). 1: Signal detected. (RXLOS = 0 or SUPPRESS_RXLOS = 1).	0

**Table 60 • Factory Test Register (1×000B-000D)**

Bit	Name	Access	Description	Default
15:0	Reserved	RO	Factory test only; do not modify this bit group	0

**Table 61 • PMA\_PKGID1: PMA Package Identifier 1 (1×000E)**

Bit	Name	Access	Description	Default
15:0	PKG_ID_MSW	RO	Upper 16 bits of a 32-bit unique PMA package identifier. Bits 3-18 of the device manufacturer's OUI.	0

**Table 62 • PMA\_PKGID2: PMA Package Identifier 2 (1×000F)**

Bit	Name	Access	Description	Default
15:0	PKG_ID_LSW	RO	Lower 16 bits of a 32-bit unique PMA package identifier. Bits 19-24 of the device manufacturer's OUI. Six-bit model number, and a four-bit revision number.	0

**Table 63 • PMA\_CFG1: PMA Configuration 1 (1×8000)**

Bit	Name	Access	Description	Default
15:14	CRU_LOOP_BANDWIDTH[1:0 ]	RW	CRU loop bandwidth adjustment 00: ~10 MHz 01: ~13 MHz 10: ~16 MHz 11: ~19 MHz	10
13	RX_SQU_MAN_EN	RW	Rx_SQUELCHING manual mode enable. 0: Enable 1: Disable For more information, see <a href="#">Table 68</a> , page 104.	1
12	Reserved	RO	Factory test only; do not modify this bit	1
11	Reserved	RO	Factory test only; do not modify this bit	0
10	Reserved	RWSC	Factory test only; do not modify this bit	1
9	Reserved	RW	Factory test only; do not modify this bit	0
8	LPBKN_K	RW	Disable PMA serial loopback (loopback K) 0: Enable 1: Disable	1
7	TX_DATAINVN	RW	Selects polarity of the transmit XFI/SFI data 0: Invert Tx data polarity 1: Normal operation	1
6	TX_MSBSEL	RW	Selects the transmission bit order 0: MSB transmitted first with bit 63 being the MSB 1: LSB transmitted first with bit 0 being the MSB (IEEE style)	1
5	Reserved	RW	Factory test only; do not modify this bit	0
4	Reserved	RW	Factory test only; do not modify this bit	1

**Table 63 • PMA\_CFG1: PMA Configuration 1 (1×8000) (continued)**

Bit	Name	Access	Description	Default
3	RX_LOSDATASQN	RW	Selects data squelch mode (See Lock to Reference Table within the text) 0: Automatic data squelch mode 1: Manual data squelch mode	1
2	RX_LCKREFN	RW	Selects Lock to Reference (See Lock to Reference Table within the text) 0: Lock to Refclk (squelch data) 1: Normal operation	1
1	RX_DATAINVN	RW	Selects polarity of the receive XFI/SFI data 0: Invert Rx data polarity 1: Normal operation	1
0	RX_MSBSELN	RW	Selects the receive bit order 0: MSB received first with bit 63 being the MSB 1: LSB received first with bit 0 being the MSB (IEEE style)	1

**Table 64 • Factory Test Register (1×8001)**

Bit	Name	Access	Description	Default
15:1	Reserved	RO	Reserved (ignore when read)	0
0	Reserved	RO	Factory test only; do not modify this bit	1

**Table 65 • PMA\_RXEQ\_CTRL: PMA Rx Equalization Control (1×8002)**

Bit	Name	Access	Description	Default
15	Reserved	RO	Factory test only; do not modify this bit	1
14:11	RX_EQ_CTRL	RW	Amount of receive signal equalization	1111
10:0	Reserved	RO	Factory test only; do not modify this bit group	1010101010

**Table 66 • PMA\_STAT4: PMA Status 4 (1×E600)**

Bit	Name	Access	Description	Default
15:4	Reserved	RO	Reserved (ignore when read)	0
3	Reserved	RO	Factory test only; do not modify this bit	1
2	TXLOCKERRN	RO	Transmit clock multiplier lock error status 0: Lock error 1: Normal operation	1
1	RXLOCKERRN	RO	Receive clock recovery lock error status 0: Lock error 1: Normal operation	1

**Table 66 • PMA\_STAT4: PMA Status 4 (1×E600) (continued)**

Bit	Name	Access	Description	Default
0	RXLOS_N	RO	Receiver loss of signal status 0: Loss of signal 1: Normal operation	N/A <sup>1</sup>

1. The status of this bit changes and is dependent on the condition of the connected PMD.

**Table 67 • PMA\_CTRL4: PMA Control 4 (1×E601)**

Bit	Name	Access	Description	Default
15:8	Reserved	RO	Factory test only; do not modify this bit group	10101010
7:4	TX_EMPH_SEL	RW	Amount of PMA transmit pre-emphasis Type 1 0000: 1.8 dB (default) 0100: 2.7 dB 1000: 3.3 dB 1111: 3.9 dB Type 2 0000: 3.8 dB 0100: 4.8 dB 1000: 6.2 dB 1111: 6.4 dB	0
3:0	TX_SLEW_SEL	RW	Amount of PMA transmit slew rate 0000: Type 1 1111: Type 2 all others: Reserved	0

**Table 68 • PMA\_CTRL5: PMA Control 5 (1×E602)**

Bit	Name	Access	Description	Default
15	TX_SQUELCH	RW	Enables transmit data squelch. Force all zeros out the serial interface 0: Disable 1: Enable	0
14	RX_SQUELCH	RW	Enables received data squelch. Forces all zeros into the core. 0: Disable 1: Enable To enable the RX_SQUELCH manually, register 1×8000.13 must be set to 0. Otherwise, the default setting is to squelch the RX output automatically. For more information, see <a href="#">Table 63, page 102</a> .	0
13	Reserved	RW	Factory test only; do not modify this bit	0
12	Reserved	RW	Factory test only; do not modify this bit	0
11	Reserved	RW	Factory test only; do not modify this bit	0

**Table 68 • PMA\_CTRL5: PMA Control 5 (1×E602) (continued)**

Bit	Name	Access	Description	Default
10	FULLSWG_EXVCO	RW	Enables high swing on EXVCOPU/PD output signals 0: Low swing 1: High swing	0
9	CLK64A_ENA	RW	Enables the CLK64A output signal. This signal is used when CLK64A_SRC is asserted. 0: Disable 1: Enable	0
8:7	CLK64A_SEL	RW	Selects which internal clock signal to output on CLK64A 00: CMU divided by 64 01: CMU divided by 66 10: CRU divided by 64 11: REFCK	0
6	CLK64A_SRC	RW	Selects the source of the CLK64_EN signal 0: Enables CLK64A through the CLK64_EN pin 1: Enables CLK64A through the CLK64A_ENA (1×E602.9)	0
5	CLK64B_ENA	RW	Enables the CLK64B output 0: Disable 1: Enable	0
4:3	CLK64B_SEL	RW	Selects which internal clock signal to output on CLK64B 00: CRU divided by 64 01: CMU divided by 66 10: CMU divided by 64 11: Factory test	0
2	SYNC_E	RW	Enables mode override for Synchronous Ethernet application. Enabling this bit allows usage of the REFCLK, WREFCLK, and VREFCLK clocks for the XAUI, CMU, and CRU blocks separately in LAN mode. For more information, see register <a href="#">Table 70</a> , page 106.	0
1	Reserved	RO	Reserved (value always 0, writes ignored)	0
0	Reserved	RO	Reserved (value always 0, writes ignored)	0

**Table 69 • High-Speed Data Output (Signal Quality Control) (1×E603)**

Bit	Name	Access	Description	Default
15:8	OUT_DEMP	R/W	Output de-emphasis adjustment. 00000000: Minimum de-emphasis. 11111111: Maximum de-emphasis. Values in between are not linear.	0
7:0	OUT_SWING	R/W	Output swing adjustment. 00000000: Minimum swing. 11111111: Maximum swing. Values in between are not linear.	0

**Table 70 • Synchronous Ethernet Clock Control (1×E604)**

Bit	Name	Access	Description	Default
15	GAIN_SEL	R/W	XFI input gain factor select. 0: Enable high gain factor. 1: Enable low gain factor. Low gain factor is similar to the low gain factor in VSC8476-01 device. <b>Note:</b> For applications that do not require high input gain, set this bit to 1 for optimal jitter tolerance.	0
14:8	Reserved	R/W	Reserved.	0
7	CMU_INTCLK_EN	R/W	CMU clock source. 0: Reserved. 1: CMU REFCLK is from internal CRU recovered clock divided by 64.	0
6:5	CRU_CLKSEL	R/W	CRU clock source. 00: CRU source clock is from REFCLK 01: CRU source clock is from WREFCLK (divided by 64). 10: CRU source clock is from WREFCLK (divided by 16). 11: Reserved.	0
4:3	CMU_CLKSEL	R/W	CMU clock source. 00: Reserved. 01: CMU source clock is from REFCLK. 10: CMU source clock is from internal CRU recovered clock and bit 7 needs to be set to 1. 11: CMU source clock is from VREFCLK.	0
2:1	CMUCLK_DVDR	R/W	Divider for CMU clock. 00: CMU source clock is divided by 64. 01: CMU source clock is divided by 16. 1×: CMU source clock is divided by 66.	0
0	CRUCLK_DVDR	R/W	Divider for CRU clock 0: CRU source clock is divided by 64. 1: CRU source clock is divided by 66.	0

**Table 71 • DEV\_CTRL3: DEVICE Control 3 (1×E605)**

Bit	Name	Access	Description	Default
15	WIS_INTB_POL	RW	Active level (polarity) used for the output pin, WIS_INTB 0: Active low 1: Active high	0
14	WIS_INTA_POL	RW	Active level (polarity) used for the output pin, WIS_INTA 0: Active low 1: Active high	0

**Table 71 • DEV\_CTRL3: DEVICE Control 3 (1×E605) (continued)**

Bit	Name	Access	Description	Default
13	AUTONEG_OVR	RW	Enables overriding the input pin value and instead use the force bit setting 0: Use the AUTONEG input pin state 1: Override enable	0
12	AUTONEG_FRC	RW	Value to be used if the override bit is enabled 0: If AUTONEG_OVR = 1, AUTONEG = 0 1: If AUTONEG_OVR = 1, AUTONEG = 1	0
11	EPCS_OVR	RW	Enables overriding the input pin value and instead use the force bit setting 0: Use the EPCS input pin state 1: Override enable	0
10	EPCS_FRC	RW	Value to be used if the override bit is enabled 0: If EPCS_OVR = 1, EPCS = 0 1: If EPCS_OVR = 1, EPCS = 1	0
9	TXONOFF_OVR	RW	Enables overriding the input pin value and instead use the force bit setting 0: Use the TXONOFFI pin state 1: Use the TXONOFF_FRC value when TXONOFFI pin = low. <b>Note:</b> The TXONOFFI pin must be set high for register bits 9:8 to override the transmit output.	0
8	TXONOFF_FRC	RW	Value to be used if the override bit is enabled 0: If TXONOFF_OVR = 1, TXONOFFI = 0 1: If TXONOFF_OVR = 1, TXONOFFI = 1 <b>Note:</b> The TXONOFFI pin must be set high for register bits 9:8 to override the transmit output.	0
7	REFSEL0_OVR	RW	Enables overriding the input pin value and instead use the force bit setting 0: Use the REFSEL0 input pin state 1: Override enable	0
6	REFSEL0_FRC	RW	Value to be used if the override bit is enabled 0: If REFSEL0_OVR = 1, REFSEL0 = 0 1: If REFSEL0_OVR = 1, REFSEL0 = 1	0
5	Reserved	RO	Reserved (ignored when read)	0
4	LINETIME_FRC	RW	Force the device into linetime mode 0: Normal operation 1: Linetime enable	0
3	WAN_OVR	RW	Enables overriding the input pin value and instead use the force bit setting 0: Use the WAN input pin state 1: Override enable	0
2	WAN_FRC	RW	Value to be used if the override bit is enabled 0: If WAN_OVR = 1, WAN is disabled regardless of any other control setting 1: If WAN_OVR = 1, WAN is enabled regardless of any other control setting	0



**Table 71 • DEV\_CTRL3: DEVICE Control 3 (1×E605) (continued)**

Bit	Name	Access	Description	Default
1	SUPPRESS_RXLO L	RW	Disable receive LOL status from propagating into the fault logic 0: Receive LOL signal is used for fault logic 1: Receive LOL signal is ignored by fault logic	0
0	SUPPRESS_RXLO S	RW	Disable receive LOS status from propagating into the fault logic 0: Receive LOS signal is used for fault logic 1: Receive LOS signal is ignored by fault logic	0

**Table 72 • DEV\_STAT1: DEVICE Status 1 (1×E606)**

Bit	Name	Access	Description	Default
15	WAN_STAT	RO	Status of WAN mode 0: Disabled 1: Enabled	0
14	WAN_MODE_PSTAT	RO	Input level received on the WAN_MODE pin 0: Low 1: High	0
13	LINETIME_STAT	RO	Current state of the linetime signal 0: Low 1: High	0
12	REFSEL0_PSTAT	RO	Input level received on the REFSEL0 pin 0: Low 1: High	0
11	LPP_10B_PSTAT	RO	Input level received on the LPP_10B pin 0: Low 1: High	0
10	LP_XAUI_PSTAT	RO	Input level received on the LP_XAUI pin 0: Low 1: High	0
9	SPLITLOOPN_PSTA T	RO	Input level received on the SPLITLOOPN pin 0: Low 1: High	0
8	LP_XGMII_PSTAT	RO	Input level received on the LP_XGMII pin 0: Low 1: High	0
7	LP_16B_PSTAT	RO	Input level received on the LP_16B pin 0: Low 1: High	0
6	IOMODESEL_PSTA T	RO	Input level received on the IOMODESEL pin 0: Low 1: High	0
5	AUTONEG_PSTAT	RO	Input level received on the AUTONEG pin 0: Low 1: High	0

**Table 72 • DEV\_STAT1: DEVICE Status 1 (1×E606) (continued)**

Bit	Name	Access	Description	Default
4	EPCS_PSTAT	RO	Input level received on the EPCS pin 0: Low 1: High	0
3	TXONOFF_PSTAT	RO	Input level received on the TXONOFFI pin 0: Low 1: High	0
2	Reserved	RO	Factory test only; do not modify this bit	0
1	Reserved	RO	Factory test only; do not modify this bit	0
0	Reserved	RO	Factory test only; do not modify this bit	0

**Table 73 • DEV\_STAT2: DEVICE Status 2 (1×E607)**

Bit	Name	Access	Description	Default
15:13	MST_CODE_PSTAT	RO	Received signal levels of the MST_CODE[2:0] input pins.	0
12	Reserved	RO	Factory test only; do not modify this bit.	0
11	Reserved	RO	Factory test only; do not modify this bit.	0
10	Reserved	RO	Factory test only; do not modify this bit.	0
9	Reserved	RO	Factory test only; do not modify this bit.	0
8	Reserved	RO	Factory test only; do not modify this bit.	0
7	Reserved	RO	Factory test only; do not modify this bit.	0
6	EPCS_PSTAT	RO	Input level received on the EPCS pin. 0: Low. 1: High.	0
5	AUTONEG_PSTAT	RO	Input level received on the AUTONEG pin. 0: Low. 1: High.	0
4	FORCEAIS_PSTAT	RO	Input level received on the FORCEAIS pin. 0: Low. 1: High.	0
3	WIS_INTA_PSTAT	RO	Output level sent on the WIS_INTA pin. 0: Low. 1: High.	0
2	WIS_INTB_PSTAT	RO	Output level sent on the WIS_INTB pin. 0: Low. 1: High.	0
1	PMTICK_PSTAT	RO	Input level received on the TESTEN pin. 0: Low. 1: High.	0
0	LOPC_PSTAT	RO	Input level received on the LOPC pin. 0: Low. 1: High.	0

**Table 74 • PMA\_LOS\_ASSERT: PMA Loss of Signal Assert Control (1×E700)**

Bit	Name	Access	Description	Default
15:10	Reserved	RO	Reserved.	0
9	Reserved	RW	Factory test only; do not modify this bit.	0
8	Reserved	RW	Factory test only; do not modify this bit.	0
7	Reserved	RW	Factory test only; do not modify this bit.	0
6	LOS_MODE_SEL	RW	Selects which style of LOS monitoring to use. 0: Monitor LOS at the input. 1: Monitor LSO after signal cleanup. Must be 0 for correct sensitivity performance in the VSC8486-04.	0
5:0	LOS_ASSERT_DA C	RW	Set the LOS assert voltage threshold. 001100: Less than 75 mV. 010010: Greater than 110 mV. All else: Reserved.	0

**Table 75 • PMA\_LOS\_DEASSERT: PMA Loss of Signal Deassert Control (1×E701)**

Bit	Name	Access	Description	Default
15	LOS_EN	RW	Enables LOS circuitry. 0: Enable PMA LOS. 1: Disable PMA LOS.	1
14:12	LOS_WIN	RW	LOS report/clear time setting.	0
11:8	VCM_ADJ	RW	Input receiver common mode voltage adjust. Observable on RXINCM (pin N3).	1000
7	Reserved	RW	Factory test only; do not modify this bit	0
6	Reserved	RW	Factory test only; do not modify this bit	0
5:0	LOS_DEASSERT_DA C	RW	Set the LOS deassert voltage threshold. 001100: Less than 75 mV. 010010: Greater than 110 mV. All else: Reserved.	0

**Table 76 • PMA\_LOS\_STAT: PMA Loss of Signal Status (1×E702)**

Bit	Name	Access	Description	Default
15:3	Reserved	RO	Reserved	0
2	LOS_ASSERT_STAT	RO	Assert comparison (see also 1×E700.5:0) 0: Assert threshold is less than peak detector monitor 1: Assert threshold is greater than peak detector monitor	N/A <sup>1</sup>

**Table 76 • PMA\_LOS\_STAT: PMA Loss of Signal Status (1×E702) (continued)**

Bit	Name	Access	Description	Default
1	LOS_DEASSERT_STAT	RO	Deassert comparison (see also 1×E701.5:0) 0: Deassert threshold is less than peak detector monitor 1: Deassert threshold is greater than peak detector monitor	N/A <sup>1</sup>
0	LOS_STAT	RO	Loss of signal status (identical to 1×E600.0) 0: Loss of signal 1: Normal operation	N/A <sup>1</sup>

1. The status of this bit changes and is dependent on the condition of the connected PMD.

**Table 77 • DEV\_ID: DEVICE Identifier (1×E800)**

Bit	Name	Access	Description	Default
15:0	CHIP_ID	RO	Contains the identification number of the device	0×8486

**Table 78 • DEV\_REV: DEVICE Revision (1×E801)**

Bit	Name	Access	Description	Default
15:0	CHIP_REV	RO	Contains the revision number of the device	0×0004

**Table 79 • Factory Test Register (1×E900)**

Bit	Name	Access	Description	Default
15:0	Reserved	RO	Factory test only; do not modify this bit group	0

**Table 80 • DEV\_GPIO\_CTRL: DEVICE General Purpose I/O Control (1×E901)**

Bit	Name	Access	Description	Default
15	Reserved	RO	Reserved (value always 0, writes ignored)	0
14:13	TXALARM_SEL	RW	Selects source of TXALARM output 00: Normal TXALARM 01: Tx link/activity LED 10: GPO mode 11: Reserved	0
12:11	RXALARM_SEL	RW	Selects source of RXALARM output 00: Normal RXALARM 01: Rx link/activity LED 10: GPO mode 11: Reserved	0
10	LASI_SEL	RW	Selects source of LASI output 0: Normal LASI output 1: GPO mode	0

**Table 80 • DEV\_GPIO\_CTRL: DEVICE General Purpose I/O Control (1×E901) (continued)**

Bit	Name	Access	Description	Default
9	WIS_INTB_SEL	RW	Selects source of WIS_INTB output 0: XFP module reset or SFP+ TXDISABLE 1: WIS interrupt B function	0
8	GPO_TXALARM	RW	Transmitted on TXALARM when in GPO mode	0
7	GPO_RXALARM	RW	Transmitted on RXALARM when in GPO mode	0
6	GPO_LASI	RW	Transmitted on LASI when in GPO mode	0
5	TX_LED_BLINK_TIME	RW	Tx data activity LED blink time 0: 50 ms interval 1: 100 ms interval	1
4	RX_LED_BLINK_TIME	RW	Rx data activity LED blink time 0: 50 ms interval 1: 100 ms interval	1
3:2	TX_LED_MODE	RW	00: Display Tx link status (XAUI mode)/display Tx data activity status (XGMII mode) 01: Display Tx data activity status 10: Display combination of link and data activity status (XAUI mode)/display data activity status (XGMII mode) 11: Reserved	10
1:0	RX_LED_MODE	RW	Rx LED mode control 00: Display Rx link status 01: Display Rx data activity status 10: Display combo of link and data activity status 11: Reserved	10

**Table 81 • DEV\_XFP\_CTRL: DEVICE XFP Control (1×E902)**

Bit	Name	Access	Description	Default
15:3	Reserved	RO	Reserved (value always 0, writes ignored)	0
2	XFP_RST_ON_LOWPOWER R  or  SFP+_Tx_DIS	RW	<b>XFP</b> Select for XFP reset on low power mode 0: No low power mode contribution to XFP reset 1: XFP reset in low power mode  <b>SFP+</b> Select for Tx_DIS 0: SFP+ module functioning regardless of no low power mode 1: Disables SFP+ module in low power mode	1

**Table 81 • DEV\_XFP\_CTRL: DEVICE XFP Control (1×E902) (continued)**

Bit	Name	Access	Description	Default
1	XFP_RST_INV or SFP+_Tx_DIS_INV	RW	<b>XFP</b> Invert XFP reset state on WIS_INTB 0: Active high 1: Active low  <b>SFP+</b> Invert SFP+ Tx_DIS state on WIS_INTB 0: Active high 1: Active low	0
0	XFP_RST or SFP+_DIS	RW	<b>XFP</b> Force XFP power-down reset 0: Normal operation 1: Hold in power down reset state  <b>SFP+</b> Force SFP+ transmit to be disabled 0: Normal operation 1: Hold the SFP+ transmit in disable state	0

**Table 82 • Factory Test Register (1×EC00)**

Bit	Name	Access	Description	Default
15:0	TEST	RO	Factory test only; do not modify this bit group	0

**Table 83 • Factory Test (1×EC01–EC34)**

Bit	Name	Access	Description	Default
15:0	Reserved	RO	Reserved (value always 0, writes ignored)	0

**Table 84 • Factory Test (1×ED00–ED0F)**

Bit	Name	Access	Description	Default
15:0	TEST	RW	Factory test only; do not modify this bit group	0

**Table 85 • Factory Test Register (1×EF00)**

Bit	Name	Access	Description	Default
15:0	TEST	RO	Factory test only; do not modify this bit group	0

**Table 86 • DEV\_RST\_CTRL: DEVICE Block Reset Control (1×EF01)**

Bit	Name	Access	Description	Default
15	STW_CTRL_RST	RWSC	A block level software reset for the two-wire serial controller. <b>Note:</b> This register only resets the local two-wire serial circuit. It cannot be used to reset downstream SFP+/XFP devices.	0
14:9	Reserved	RW	Reserved	0
8	RST_WIS_TX	RWSC	Reset the WIS Tx path 0: Normal operation 1: WIS Tx path reset	0
7	RST_WIS_TXFIFO	RWSC	Reset the Tx WIS FIFO 0: Normal operation 1: Tx WIS FIFO reset	0
6	RST_WIS_TXFIFOPTR	RWSC	Reset the Tx WIS FIFO pointers 0: Normal operation 1: Tx WIS FIFO pointer reset	0
5	RST_WIS_INTR	RWSC	Reset the WIS interrupt tree 0: Normal operation 1: Reset WIS interrupt tree	0
4	RST_WIS_RXFIFO	RWSC	Reset the Rx WIS FIFO 0: Normal operation 1: Rx WIS FIFO reset	0
3	RST_WIS_RX	RWSC	Reset the WIS Rx path 0: Normal operation 1: WIS Rx path reset	0
2	RST_PCS_TX	RWSC	Reset the PCS Tx path 0: Normal operation 1: PCS Tx path reset	0
1	RST_PCS_RX	RWSC	Reset the PCS Rx path 0: Normal operation 1: PCS Rx path reset	0
0	RST_XGXS_FIFO	RWSC	Reset the XGXS FIFO 0: Normal operation 1: XGXS FIFO reset	0

**Table 87 • DEV\_XFI\_CTRL2: DEVICE XFI Loopback Control 2 (1×EF10)**

Bit	Name	Access	Description	Default
15:3	Reserved	RO	Reserved (value always 0, writes ignored)	0
2	XFI_LPBK_OVR	RW	Override the default data pattern to transmit out the XFI port while in loopback 0: Normal operation 1: Override XFI transmit data according to bits 1:0.	0

**Table 87 • DEV\_XFI\_CTRL2: DEVICE XFI Loopback Control 2 (1×EF10) (continued)**

Bit	Name	Access	Description	Default
1:0	XFI_TXDATA_SEL	RW	Selects the data pattern to transmit out the XFI port while in loopback 00: 0×00FF repeating pattern 01: All zeros 10: All ones 11: Tx data from WIS/PCS	0

## 4.2 Device 2: WIS Registers

The following tables provide settings for the registers related to WIS.

**Table 88 • WIS\_CTRL1: WIS Control 1 (2×0000)**

Bit	Name	Access	Description	Default
15	SOFT_RST	RWSC	Reset all MMDs. 0: Normal operation. 1: Reset.	0
14	LPBK_J	RW	Enables WIS system loopback (loopback J). 0: Disable. 1: Enable.	0
13	SPEED_SEL_A	RO	WIS speed capability. 0: Unspecified. 1: Operates at 10 Gbps or above.	1
12	Reserved	RO	Reserved.	0
11	LOW_PWR	RW	Enter low power mode. 0: Normal operation. 1: Low power mode. The XAUI and PMA high-speed output driver are disabled. TXEN is active to indicate low power state. Register bit TXEN_INV (1×E602.12) selects whether TXEN is active high or low.	0
10:7	Reserved	RO	Reserved.	0
6	SPEED_SEL_B	RO	WIS speed capability. 0: Unspecified. 1: Operates at 10 Gbps or above.	1
5:2	SPEED_SEL_C	RO	WIS speed selection. 1xx: Reserved. x1x: Reserved. xx1x: Reserved. 0001: Reserved. 0000: 10 Gbps.	0
1:0	Reserved	RO	Reserved.	0

**Table 89 • WIS\_STAT1: WIS Status 1 (2×0001)**

Bit	Name	Access	Description	Default
15:8	Reserved	RO	Reserved.	0



**Table 89 • WIS\_STAT1: WIS Status 1 (2×0001) (continued)**

Bit	Name	Access	Description	Default
7	FAULT	RO	0: No faults asserted. 1: Fault asserted. For more information about the cause of the fault, see <a href="#">Table 176</a> , page 152.	0
6:3	Reserved	RO	Reserved.	0
2	LNK_STAT	RO/LL	WIS receive link status. Link up means no AIS-P, AIS-L, PLM-P, or SEF alarms. 0: Link down. 1: Link up. Link up: AIS-P = 0 and AIS-L = 0 and PLM-P = 0 and WIS SEF = 0. <b>Note:</b> WIS link down: AIS-P = 1 or AIS-L = 1 or PLM-P = 1 or WIS SEF = 1.	1
1	LOW_PWR_ABILITY	RO	Low power mode support ability. 0: Not supported. 1: Supported.	1
0	Reserved	RO	Reserved.	0

**Table 90 • WIS\_DEVID1: WIS Device Identifier 1 (2×0002)**

Bit	Name	Access	Description	Default
15:0	DEV_ID_MSW	RO	Upper 16 bits of a 32-bit unique WIS device identifier. Bits 3-18 of the device manufacturer's OUI.	0×0007

**Table 91 • WIS\_DEVID2: WIS Device Identifier 2 (2×0003)**

Bit	Name	Access	Description	Default
15:0	DEV_ID_LSW	RO	Lower 16 bits of a 32-bit unique WIS device identifier. Bits 19-24 of the device manufacturer's OUI. Six-bit model number, and a four-bit revision number.	0×0400

**Table 92 • WIS\_SPEED: WIS Speed Capability (2×0004)**

Bit	Name	Access	Description	Default
15:1	Reserved	RO	Reserved	0
0	RATE_ABILITY	RO	WIS rate capability 0: Not capable of 10 Gbps 1: Capable of 10 Gbps	1

**Table 93 • WIS\_DEVPKG1: WIS Devices in Package 1 (2×0005)**

Bit	Name	Access	Description	Default
15:6	Reserved	RO	Reserved	0
5	DTE_XS_PRES	RO	Indicates whether DTE XS is present in the package 0: Not present 1: Present	0
4	PHY_XS_PRES	RO	Indicates whether PHY XS is present in the package (this bit depends upon the IOMODESEL pin setting) 0: Not present 1: Present	1
3	PCS_PRES	RO	Indicates whether PCS is present in the package 0: Not present 1: Present	1
2	WIS_PRES	RO	Indicates whether WIS is present in the package 0: Not present 1: Present	1
1	PMD_PMA_PRES	RO	Indicates whether PMA/PMD is present in the package 0: Not present 1: Present	1
0	CLS22_PRES	RO	Indicates whether Clause 22 registers are present in the package 0: Not present 1: Present	0

**Table 94 • WIS\_DEVPKG2: WIS Devices in Package 2 (2×0006)**

Bit	Name	Access	Description	Default
15	VS2_PRES	RO	Vendor specific device 2 present 0: Not present 1: Present	0
14	VS1_PRES	RO	Vendor specific device 1 present 0: Not present 1: Present	0
13:0	Reserved	RO	Reserved	0

**Table 95 • WIS\_CTRL2: WIS Control 2 (2×0007)**

Bit	Name	Access	Description	Default
15:6	Reserved	RO	Reserved.	0
5	TEST_PRBS31_ANA	RW	Enables WIS PRBS31 test pattern checking function. 0: Disabled. 1: Enabled.	0

**Table 95 • WIS\_CTRL2: WIS Control 2 (2×0007) (continued)**

Bit	Name	Access	Description	Default
4	TEST_PRBS31_GEN	RW	Enables WIS PRBS31 test pattern generation function. 0: Disable. 1: Enable.	0
3	TEST_PAT_SEL	RW	Selects the pattern type sent by the transmitter when TEST_PAT_GEN (2×0007.1) is low. 0: Mixed frequency test pattern. 1: Square wave.	0
2	TEST_PAT_ANA	RW	Enables the WIS test pattern checker. Doing so prevents the loss of code-group delineation (LCD-P) alarm from being set while the WIS is receiving the mixed frequency test pattern. 0: Disable. 1: Enable.	0
1	TEST_PAT_GEN	RW	Enables WIS test pattern generation. 0: Disable. 1: Enable.	0
0	WAN_MODE	RW	Enables 10GBASE-W logic and sets the speed of the WIS-PMA interface to 9.95328 Gbps. The proper reference clock frequency must be provided to set the data rate. There are multiple ways to enable WAN mode. 0: Disable. 1: Enable.	0

**Table 96 • WIS\_STAT2: WIS Status 2 (2×0008)**

Bit	Name	Access	Description	Default
15:14	DEV_PRESENCE	RO	Reflects the presence of a MMD responding at this address 00: No device responding at this address 01: No device responding at this address 10: Device responding at this address 11: No device responding at this address	10
13:2	Reserved	RO	Reserved	0
1	PRBS31_ABILITY	RO	Indicates if WIS supports PRBS31 pattern testing 0: Not supported 1: Supported	1
0	BASE_R_ABILITY	RO	Indicates if WIS supports a bypass to allow support of 10GBASE-R 0: Not supported 1: Supported	1

**Table 97 • WIS\_TSTPAT\_CNT: WIS Test Pattern Error Counter (2×0009)**

Bit	Name	Access	Description	Default
15:0	TSTPAT_CNT	ROCR	PRBS31 test pattern error counter. The saturating counter clears on read. The error count is not valid until the SYNC bit in 2×EC51.0 is asserted. The error count can be incrementing while the checker is acquiring sync. To clear the invalid error count when sync is achieved, read 2×0009. After the counter begins to increment, the counting is not affected by changes to the pattern synchronization.	0

**Table 98 • WIS\_PKGID1: WIS Package Identifier 1 (2×000E)**

Bit	Name	Access	Description	Default
15:0	PKG_ID_MSW	RO	Upper 16 bits of a 32-bit unique WIS package identifier. Bits 3-18 of the device manufacturer's OUI. Six-bit model number and a four-bit revision number.	0

**Table 99 • WIS\_PKGID2: WIS Package Identifier 2 (2×000F)**

Bit	Name	Access	Description	Default
15:0	PKG_ID_LSW	RO	Lower 16 bits of a 32-bit unique WIS package identifier. Bits 19-24 of the device manufacturer's OUI. Six-bit model number and a four-bit revision number.	0

**Table 100 • WIS\_STAT3: WIS Status 3 (2×0021)**

Bit	Name	Access	Description	Default
15:12	Reserved	RO	Reserved	0
11	SEF	RO/LH	Severely errored frame 0: No SEF detected 1: SEF detected	0
10	FEPLMP_LCDP	RO/LH	Indicates far-end PLM-P/LCD-P defect in WIS Rx 0: No far-end path label mismatch/loss of code-group delineation 1: Far-end path label mismatch/loss of code-group delineation	0
9	FEAISP_LOPP	RO/LH	Indicates far-end AIS-P/LOP-P defect in WIS Rx 0: Far-end path alarm indication signal/path loss of pointer 1: No far-end path alarm indication signal/path loss of pointer	0
8	Reserved	RO	Reserved	0

**Table 100 • WIS\_STAT3: WIS Status 3 (2×0021) (continued)**

Bit	Name	Access	Description	Default
7	LOF	RO/LH	Loss of frame 0: Loss of frame flag lowered 1: Loss of frame flag raised	0
6	LOS	RO/LH	Loss of signal 0: Loss of signal flag lowered 1: Loss of signal flag raised	0
5	RDIL	RO/LH	Line remote defect indication 0: Line remote defect flag lowered 1: Line remote defect flag raised	0
4	AISL	RO/LH	Line alarm indication signal 0: Line alarm indication flag lowered 1: Line alarm indication flag raised	0
3	LCDP	RO/LH	Path loss of code-group delineation 0: Path loss of code-group delineation flag lowered 1: Path loss of code-group delineation flag raised	0
2	PLMP	RO/LH	Path label mismatch 0: Path label mismatch flag lowered 1: Path label mismatch flag raised	0
1	AISP	RO/LH	Path alarm indication signal 0: Path alarm indication signal lowered 1: Path alarm indication signal raised	0
0	LOPP	RO/LH	Loss of pointer 0: Loss of pointer flag lowered 1: Loss of pointer flag raised	0

**Table 101 • WIS\_REI\_CNT: WIS Far-End Path Block Error Count (2×0025)**

Bit	Name	Access	Description	Default
15:0	REIP_CNT	RO	Far-end path block error count. Counter wraps around to 0 when it is incremented beyond its maximum error count of 65,535.	0

**Table 102 • WIS\_TXJ1: WIS Tx J1s (2×0027-002E)**

Bit	Name	Access	Description	Default
15:8	TX_J1_ODD	RW	Contains one octet of the transmitted path trace message. The transmitted path trace octet 1 is in address 2×0027. Octet 3 is in address 2×0028. Octet 15 is in address 2×002E.	00 (registers 2×0027 to 2×002D) 0×89 (register 2×002E)

**Table 102 • WIS\_TXJ1: WIS Tx J1s (2×0027-002E) (continued)**

Bit	Name	Access	Description	Default
7:0	TX_J1_EVEN	RW	Contains one octet of the transmitted path trace message. The transmitted path trace octet 0 is in address 2×0027. Octet 2 is in address 2×0028. Octet 14 is in address 2×002E.	0

**Table 103 • WIS\_RXJ1: WIS Rx J1s (2×002F-0036)**

Bit	Name	Access	Description	Default
15:8	RX_J1_ODD	RO	Contains one octet of the received path trace message. The received path trace octet 1 is in address 2×002F. Octet 3 is in address 2×0030. Octet 15 is in address 2×0036.	0
7:0	RX_J1_EVEN	RO	Contains one octet of the received path trace message. The received path trace octet 0 is in address 2×002F. Octet 2 is in address 2×0030. Octet 14 is in address 2×0036.	0

**Table 104 • WIS\_REIL\_CNT1: WIS Far-End Line BIP Errors 1 (2×0037)**

Bit	Name	Access	Description	Default
15:0	REIL_ERR_CNT_MS W	RO	Most significant word of the WIS far-end line BIP error counter.	0

**Table 105 • WIS\_REIL\_CNT0: WIS Far-End Line BIP Errors 0 (2×0038)**

Bit	Name	Access	Description	Default
15:0	REIL_ERR_CNT_LS W	RO	Least significant word of the WIS far-end line BIP error counter.	0

**Table 106 • WIS\_B2\_CNT1: WIS L-BIP Error Count 1 (2×0039)**

Bit	Name	Access	Description	Default
15:0	B2_CNT_MSW	RO	Most significant word of the WIS line BIP error counter.	0

**Table 107 • WIS\_B2\_CNT0: WIS L-BIP Error Count 0 (2×003A)**

Bit	Name	Access	Description	Default
15:0	B2_CNT_LSW	RO	Least significant word of the WIS line BIP error counter.	0

**Table 108 • WIS\_B3\_CNT: WIS P-BIP Block Error Count (2×003B)**

Bit	Name	Access	Description	Default
15:0	B3_CNT	RO	Path block error counter. Counter wraps around to 0 when it is incremented beyond its maximum error count of 65,535. Cleared on WIS reset.	0

**Table 109 • WIS\_B1\_CNT: WIS S-BIP Error Count (2×003C)**

Bit	Name	Access	Description	Default
15:0	B1_CNT	RO	Section BIP error counter. Counter wraps around to 0 when it is incremented beyond its maximum error count of 65,535. Cleared on WIS reset.	0

**Table 110 • WIS\_TXJ0: WIS Transmit J0s (2×0040-0047)**

Bit	Name	Access	Description	Default
15:8	TX_J0_ODD	RW	Contains one octet of the transmitted section trace message. The transmitted section trace octet 1 is in address 2×0040. Octet 3 is in address 2×0041. Octet 15 is in address 2×0047.	00 (registers 2×0040 to 2×0046) 0×89 (register 2×0047)
7:0	TX_J0_EVEN	RW	Contains one octet of the transmitted section trace message. The transmitted section trace octet 0 is in address 2×0040. Octet 2 is in address 2×0041. Octet 14 is in address 2×0047.	0

**Table 111 • WIS\_RXJ0: WIS Rx J0s (2×0048-004F)**

Bit	Name	Access	Description	Default
15:8	RX_J0_ODD	RO	Contains one octet of the received section trace message. The received section trace octet 1 is in address 2×0048. Octet 3 is in address 2×0049. Octet 15 is in address 2×004F.	0

**Table 111 • WIS\_RXJ0: WIS Rx J0s (2×0048-004F) (continued)**

Bit	Name	Access	Description	Default
7:0	RX_J0_EVEN	RO	Contains one octet of the received section trace message. The received section trace octet 0 is in address 2×0048. Octet 2 is in address 2×0049. Octet 14 is in address 2×004F.	0

**Table 112 • EWIS\_TXCTRL1: WIS Vendor-Specific Tx Control 1 (2×E600)**

Bit	Name	Access	Description	Default
15	REIL_TXBLK_MODE	RW	Selects either using B2 block error count or bit error count mode to generate the M0/M1 bytes for REI-L back reporting. 0: Bit error mode 1: Block error mode	0
14	REIP_TXBLK_MODE	RW	Selects either using B3 block error count or bit error count mode to generate the G1 byte for REI-L back reporting. 0: Bit error mode 1: Block error mode	0
13	Reserved	RW	Factory test only; do not modify this bit group.	0
12	SCR	RW	Enables transmit WIS scrambler 0: Disable 1: Enable	1
11	FRC_TX_TIMP	RW	Force transmission of a TIM-P condition within the G1 byte 0: Normal operation. 1: Force TIM-P	0
10	ERDI_TX_MODE	RW	Selects ERDI as the transmit WIS G1 byte mode 0: RDI mode 1: ERDI mode	1
9	SDH_TX_MODE	RW	Selects the format of the WIS frame structure 0: SONET mode 1: SDH mode	1
8	Reserved	RW	Factory test only; do not modify this bit	0
7:4	SQ_WV_PW	RW	Selects the transmit WIS square wave test pattern length 0000 - 0011: Invalid 0100: 4 zeros and 4 ones 0101: 5 zeros and 5 ones 0110: 6 zeros and 6 ones 0111: 7 zeros and 7 ones 1000: 8 zeros and 8 ones 1001: 9 zeros and 9 ones 1010: 10 zeros and 10 ones 1011: 11 zeros and 11 ones 1100 - 1111: Invalid	0100
3	Reserved	RW	Factory test only; do not modify this bit	0



**Table 112 • EWIS\_TXCTRL1: WIS Vendor-Specific Tx Control 1 (2×E600) (continued)**

Bit	Name	Access	Description	Default
2	FRC_TX_RDI	RW	Force transmission of RDI-L in the K2 byte 0: Normal operation 1: Force RDI-L	0
1	FRC_TX_AISL	RW	Force transmission of AIS-L in the K2 byte. AIS-L takes precedence over RDI-L if both are asserted. 0: Normal operation. 1: Force AIS-L	0
0	LPBK_H	RW	Enables WIS network loopback (loopback H) 0: Disable 1: Enable	0

**Table 113 • Factory Test Register (2×E601)**

Bit	Name	Access	Description	Default
15:2	Reserved	RO	Factory test only; do not modify this bit group	0
1	Reserved	RW	Factory test only; do not modify this bit	0
0	Reserved	RWSC	Factory test only; do not modify this bit	0

**Table 114 • Factory Test Register (2×E602)**

Bit	Name	Access	Description	Default
15:8	Reserved	RO	Factory test only; do not modify this bit group	0
7:0	Reserved	RW	Factory test only; do not modify this bit	0

**Table 115 • Factory Test Register (2×E603)**

Bit	Name	Access	Description	Default
15:0	Reserved	RW	Factory test only; do not modify this bit group	0

**Table 116 • Factory Test Register (2×E604)**

Bit	Name	Access	Description	Default
15:0	Reserved	RW	Factory test only; do not modify this bit group	0

**Table 117 • Factory Test Register (2×E605)**

Bit	Name	Access	Description	Default
15:0	Reserved	RW	Factory test only; do not modify this bit group	0

**Table 118 • EWIS\_TX\_A1\_A2: E-WIS Tx A1/A2 Octets (2×E611)**

Bit	Name	Access	Description	Default
15:8	TX_A1	RW	A1 byte to be transmitted when the TOSI data is inactive.	0×F6
7:0	TX_A2	RW	A2 byte to be transmitted when the TOSI data is inactive.	0×28

**Table 119 • EWIS\_TX\_Z0\_E1: E-WIS Tx Z0/E1 Octets (2×E612)**

Bit	Name	Access	Description	Default
15:8	TX_Z0	RW	Z0 byte to be transmitted when the TOSI data is inactive	0×CC
7:0	TX_E1	RW	E1 byte to be transmitted when the TOSI data is inactive	0

**Table 120 • EWIS\_TX\_F1\_D1: E-WIS Tx F1/D1 Octets (2×E613)**

Bit	Name	Access	Description	Default
15:8	TX_F1	RW	F1 byte to be transmitted when the TOSI data is inactive	0
7:0	TX_D1	RW	D1 byte to be transmitted when the TOSI data is inactive	0

**Table 121 • EWIS\_TX\_D2\_D3: E-WIS Tx D2/D3 Octets (2×E614)**

Bit	Name	Access	Description	Default
15:8	TX_D2	RW	D2 byte to be transmitted when the TOSI data is inactive	0
7:0	TX_D3	RW	D3 byte to be transmitted when the TOSI data is inactive	0

**Table 122 • EWIS\_TX\_C2\_H1: E-WIS Tx C2/H1 Octets (2×E615)**

Bit	Name	Access	Description	Default
15:8	TX_C2	RW	C2 byte	0×1A
7:0	TX_H1	RW	H1 byte to be transmitted when the TOSI data is inactive	0×62

**Table 123 • EWIS\_TX\_H2\_H3: E-WIS Tx H2/H3 Octets (2×E616)**

Bit	Name	Access	Description	Default
15:8	TX_H2	RW	H2 byte to be transmitted when the TOSI data is inactive	0×0A
7:0	TX_H3	RW	H3 byte to be transmitted when the TOSI data is inactive	0

**Table 124 • EWIS\_TX\_G1\_K1: E-WIS Tx G1/K1 Octets (2×E617)**

Bit	Name	Access	Description	Default
15:8	Reserved	RW	Factory test only; do not modify this bit group	0
7:0	TX_K1	RW	K1 byte to be transmitted when the TOSI data is inactive	0

**Table 125 • EWIS\_TX\_K2\_F2: E-WIS Tx K2/F2 Octets (2×E618)**

Bit	Name	Access	Description	Default
15:8	TX_K2	RW	K2 byte to be transmitted when the TOSI data is inactive	0
7:0	TX_F2	RW	F2 byte	0

**Table 126 • EWIS\_TX\_D4\_D5: E-WIS Tx D4/D5 Octets (2×E619)**

Bit	Name	Access	Description	Default
15:8	TX_D4	RW	D4 byte to be transmitted when the TOSI data is inactive	0
7:0	TX_D5	RW	D5 byte to be transmitted when the TOSI data is inactive	0

**Table 127 • EWIS\_TX\_D6\_H4: E-WIS Tx D6/H4 Octets (2×E61A)**

Bit	Name	Access	Description	Default
15:8	TX_D6	RW	D6 byte to be transmitted when the TOSI data is inactive	0
7:0	TX_H4	RW	H4 byte	0

**Table 128 • EWIS\_TX\_D7\_D8: E-WIS Tx D7/D8 Octets (2×E61B)**

Bit	Name	Access	Description	Default
15:8	TX_D7	RW	D7 byte to be transmitted when the TOSI data is inactive	0
7:0	TX_D8	RW	D8 byte to be transmitted when the TOSI data is inactive	0

**Table 129 • EWIS\_TX\_D9\_Z3: E-WIS Tx D9/Z3 Octets (2×E61C)**

Bit	Name	Access	Description	Default
15:8	TX_D9	RW	D9 byte to be transmitted when the TOSI data is inactive	0
7:0	TX_Z3	RW	Z3 byte	0

**Table 130 • EWIS\_TX\_D10\_D11: E-WIS Tx D10/D11 Octets (2×E61D)**

Bit	Name	Access	Description	Default
15:8	TX_D10	RW	D10 byte to be transmitted when the TOSI data is inactive	0
7:0	TX_D11	RW	D11 byte to be transmitted when the TOSI data is inactive	0

**Table 131 • EWIS\_TX\_D12\_Z4: E-WIS Tx D12/Z4 Octets (2×E61E)**

Bit	Name	Access	Description	Default
15:8	TX_D12	RW	D12 byte to be transmitted when the TOSI data is inactive	0
7:0	TX_Z4	RW	Z4 byte	0

**Table 132 • EWIS\_TX\_S1\_Z1: E-WIS Tx S1/Z1 Octets (2×E61F)**

Bit	Name	Access	Description	Default
15:8	TX_S1	RW	S1 byte to be transmitted when the TOSI data is inactive	0×0F
7:0	TX_Z1	RW	Z1 byte to be transmitted when the TOSI data is inactive	0

**Table 133 • EWIS\_TX\_Z2\_E2: E-WIS Tx Z2/E2 Octets (2×E620)**

Bit	Name	Access	Description	Default
15:8	TX_Z2	RW	Z2 byte to be transmitted when the TOSI data is inactive	0
7:0	TX_E2	RW	E2 byte to be transmitted when the TOSI data is inactive	0

**Table 134 • EWIS\_TX\_N1: E-WIS Tx N1 Octet (2×E621)**

Bit	Name	Access	Description	Default
15:8	TX_N1	RW	N1 byte	0
7:0	Reserved	RO	Reserved	0

**Table 135 • Factory Test Register (2×E622)**

Bit	Name	Access	Description	Default
15:8	Reserved	RO	Factory test only; do not modify this bit group	0
7:0	Reserved	RO	Factory test only; do not modify this bit group	0

**Table 136 • EWIS\_TX\_MSGLEN: E-WIS Tx Trace Message Length Control (2×E700)**

Bit	Name	Access	Description	Default
15:4	Reserved	RO	Reserved	0
3:2	J0_TXLEN	RW	Selects length of transmitted section trace message 00: 16-byte trace length 01: 64-byte trace length 10: 1-byte trace length 11: 1-byte trace length	0
1:0	J1_TXLEN	RW	Selects length of transmitted path trace message 00: 16-byte trace length 01: 64-byte trace length 10: 1-byte trace length 11: 1-byte trace length	0

**Table 137 • EWIS\_TXJ0: E-WIS Tx J0s 16-63 (2×E800-E817)**

Bit	Name	Access	Description	Default
15:8	J0_TX64_ODD	RW	Contains one octet of the transmitted section trace message. Octet 17 is in 2×E800, octet 19 is in 2×E801, and so on.	0

**Table 137 • EWIS\_TXJ0: E-WIS Tx J0s 16-63 (2×E800-E817) (continued)**

Bit	Name	Access	Description	Default
7:0	J0_TX64_EVEN	RW	Contains one octet of the transmitted section trace message. Octet 16 is in 2×E800, octet 18 is in 2×E801, and so on.	0

**Table 138 • EWIS\_RXJ0: E-WIS Rx J0s 16-63 (2×E900-E917)**

Bit	Name	Access	Description	Default
15:8	J0_RX64_ODD	RO	Contains one octet of the received section trace message. Octet 17 is in 2×E900, octet 19 is in 2×E901, and so on.	0
7:0	J0_RX64_EVEN	RO	Contains one octet of the received section trace message. Octet 16 is in 2×E900, octet 18 is in 2×E901, and so on.	0

**Table 139 • EWIS\_TXJ1: E-WIS Tx WIS J1s 16-63 (2×EA00-EA17)**

Bit	Name	Access	Description	Default
15:8	J1_TX64_ODD	RW	Contains one octet of the transmitted path trace message. Octet 17 is in 2×EA00, octet 19 is in 2×EA01, and so on.	0
7:0	J1_TX64_EVEN	RW	Contains one octet of the transmitted path trace message. Octet 16 is in 2×EA00, octet 18 is in 2×EA01, and so on.	0

**Table 140 • EWIS\_RXJ1: E-WIS Rx J1s 16-63 (2×EB00-EB17)**

Bit	Name	Access	Description	Default
15:8	J1_RX64_ODD	RO	Contains one octet of the received path trace message. Octet 17 is in 2×EB00, octet 19 is in 2×EB01, and so on.	0
7:0	J1_RX64_EVEN	RO	Contains one octet of the received path trace message. Octet 16 is in 2×EB00, octet 18 is in 2×EB01, and so on.	0

**Table 141 • EWIS\_RX\_FRM\_CTRL1: E-WIS Rx Framer Control 1 (2×EC00)**

Bit	Name	Access	Description	Default
15	Reserved	RO	Reserved	0

**Table 141 • EWIS\_RX\_FRM\_CTRL1: E-WIS Rx Framer Control 1 (2×EC00) (continued)**

Bit	Name	Access	Description	Default
14:10	HUNT_A1	RW	The number of consecutive A1 octets that the receive framer must find before it can exit the HUNT state 0: Undefined 1-16: 1-16 17-31: Undefined	00100
9:5	PRESYNC_A1	RW	The number of consecutive A1 octets in the presync pattern preceding the first A2 octet 0: 1 1-16: 1-16 17-31: 16	10000
4:0	PRESYNC_A2	RW	The number of consecutive A2 octets in the presync pattern following the last A1 octet 0: Only the four MSB of the first A2 byte are compared 1-16: 1-16 17-31: 16	10000

**Table 142 • EWIS\_RX\_FRM\_CTRL2: E-WIS Rx Framer Control 2 (2×EC01)**

Bit	Name	Access	Description	Default
15:13	Reserved	RO	Reserved.	0
12:8	SYNC_PAT	RW	Synchronization pattern to be used after the presync pattern has been detected. 0: Sync pattern is A1 plus the four most significant bits of A2. 1: Sync pattern is two A1s plus one A2 (A1A1A2). 2-16: Sync pattern is the number of consecutive A1s followed by the same number of A2s. For example, the sync pattern is A1A1A2A2 when 2 is the setting. 17-31: Undefined.	00010
7:4	SYNC_ENTRY_CNT	RW	Number of consecutive frame boundaries to be detected after finding the presync pattern before the framer can enter the SYNC state. 0: 1. 1-15: 1-15.	0100
3:0	SYNC_EXIT_CNT	RW	Number of consecutive frame boundary location errors tolerated/detected before exiting the SYNC state. 0: 1. 1-15: 1-15.	0100

**Table 143 • EWIS\_LOF\_CTRL1: E-WIS Loss of Frame Control 1 (2×EC02)**

Bit	Name	Access	Description	Default
15:12	Reserved	RO	Reserved	0

**Table 143 • EWIS\_LOF\_CTRL1: E-WIS Loss of Frame Control 1 (2×EC02) (continued)**

Bit	Name	Access	Description	Default
11:6	LOF_T1	RW	Defines the number of frames periods (nominally 125 microseconds) during which OOF must persist to trigger LOF. This is not a count of continuous frames. An integrating counter is used. 0×0: Undefined. 0×1: 1 frame time (125 μs). 0×2: 2 frame times (250 μs). --- 0×18: 24 frame times (3 ms). 0×3F: 63 frame times (7.875 ms).	0×18
5:0	LOF_T2	RW	Defines the number of consecutive frame periods (nominally 125 μs) during which OOF status must not be true in order to clear loss of frame set count (the counter associated with 2×EC02.11:6). 0×0: Undefined. 0×1: 1 frame time (125 μs). 0×2: 2 frame times (250 μs). --- 0×18: 24 frame times (3 ms). 0×3F: 63 frame times (7.875 ms).	0×18

**Table 144 • EWIS\_LOF\_CTRL2: E-WIS Loss of Frame Control 2 (2×EC03)**

Bit	Name	Access	Description	Default
15:7	Reserved	RO	Reserved	0
6:1	LOF_T3	RW	Defines number of consecutive frames (normally 125 μs) for which the receive framer must be in its sync state in order to clear the LOF status 0×0: Undefined 0×1: 1 frame time (125 μs) 0×2: 2 frame times (250 μs) --- 0×18: 24 frame times (3 ms) 0×3F: 63 frame times (7.875 ms)	0×18
0	Reserved	RW	Factory test only; do not modify this bit	0

**Table 145 • EWIS\_RX\_CTRL1: E-WIS Rx Control 1 (2×EC10)**

Bit	Name	Access	Description	Default
15:2	Reserved	RO	Reserved	0
1	DSCR_ENA	RW	Enables the WIS descrambler 0: Disable 1: Enable	1



**Table 145 • EWIS\_RX\_CTRL1: E-WIS Rx Control 1 (2×EC10) (continued)**

Bit	Name	Access	Description	Default
0	B3_CALC_MOD E	RW	Selects whether or not the fixed stuff bytes are included in the receive Path BIP error calculation 0: The fixed stuff bytes are excluded from the B3 calculation 1: The fixed stuff bytes are included in the B3 calculation	1

**Table 146 • EWIS\_RX\_MSGLEN: E-WIS Rx Trace Message Length Control (2×EC20)**

Bit	Name	Access	Description	Default
15:4	Reserved	RO	Reserved	0
3:2	J0_RX_LEN	RW	Selects the expected length of the received Section trace message 00: 16-byte trace length 01: 64-byte trace length 10: 1-byte trace length 11: 1-byte trace length	0
1:0	J1_RX_LEN	RW	Selects the length of the expected Path trace message 00: 16-byte trace length 01: 64-byte trace length 10: 1-byte trace length 11: 1-byte trace length	0

**Table 147 • EWIS\_RX\_ERR\_FRC1: E-WIS Rx Error Force Control 1 (2×EC30)**

Bit	Name	Access	Description	Default
15:13	Reserved	RO	Reserved	0
12	FRC_LOPC	RW	Force a loss of optical carrier (LOPC) condition 0: Normal operation 1: Force LOPC	0
11	FRC_LOS	RW	Force a loss of signal (LOS) condition in the WIS receive data path 0: Normal operation 1: Forced receive LOS	0
10	FRC_OOF	RW	Force the receive framer into the out-of-frame (OOF) state 0: Normal operation 1: Force receive OOF	0
9	LOPC_POL_SEL	RW	Selects the polarity of the LOPC input pin 0: LOPC asserted when input is low 1: LOPC asserted when input is high	0

**Table 147 • EWIS\_RX\_ERR\_FRC1: E-WIS Rx Error Force Control 1 (2×EC30) (continued)**

Bit	Name	Access	Description	Default
8	RXLOF_ON_LOP C	RW	Selects whether or not the LOPC input has any effect on alarm conditions detected by the device 0: LOPC condition does not effect the state of the LOF or SEF status, nor the state of the receive path framer 1: LOF and SEF are asserted and the receive path framer is put into its out-of-frame state during an LOPC condition	0
7:4	APS_THRES	RW	Defines the number of consecutive frames received before asserting the AIS-L and RDI-L alarms 3-15: Threshold value All others: Reserved	0101
3	FRC_RX_AISL	RW	Force a line alarm indication signal (AIS-L) condition in the WIS receive data path 0: Normal operation 1: Device forced into Rx AIS-L condition	0
2	FRC_RX_RDIL	RW	Force a line remote defect identifier (RDI-L) condition in the WIS receive data path 0: Normal operation 1: Device forced into Rx RDI-L condition	0
1	FRC_RX_AISP	RW	Force a path alarm indication signal (AIS-P) condition in the WIS receive data path 0: Normal operation 1: Device forced into Rx AIS-P condition	0
0	FRC_RX_LOP	RW	Force a loss of pointer (LOP) condition to the starting location of the frame's SPE (synchronous payload envelope) in the WIS receive data path 0: Normal operation 1: Device forced into Rx LOP condition	0

**Table 148 • EWIS\_RX\_ERR\_FRC2: E-WIS Rx Error Force Control 2 (2×EC31)**

Bit	Name	Access	Description	Default
15	FRC_RX_UNEQP	RW	Force a unequipped path (UNEQ-P) defect in the WIS receive data path. 0: Normal operation. 1: Device forced into Rx UNEQ-P condition.	0
14	FRC_RX_PLMP	RW	Force a payload label mismatch (PLM-P) defect in the WIS receive data path. 0: Normal operation. 1: Device forced into Rx PLM-P condition.	0
13	FRC_RX_RDIP	RW	Force a far-end path remote defect identifier condition in the WIS receive data path. 0: Normal operation. 1: Device forced into Rx far-end RDI-P condition.	0

**Table 148 • EWIS\_RX\_ERR\_FRC2: E-WIS Rx Error Force Control 2 (2×EC31) (continued)**

Bit	Name	Access	Description	Default
12	FRC_RX_FE_AISP	RW	Force a far-end path alarm indication signal condition in the WIS receive data path. 0: Normal operation. 1: Device forced into Rx far-end AIS-P condition.	0
11	FRC_RX_FE_UNEQ P	RW	Force a far-end unequipped path defect in the WIS receive data path. 0: Normal operation. 1: Device forced into Rx far-end UNEQ-P condition.	0
10	FRC_RX_FE_PLMP	RW	Force a far-end payload label mismatch defect in the WIS receive data path. 0: Normal operation. 1: Device forced into Rx far-end PLM-P condition.	0
9	FRC_RX_REIP	RW	Force a path remote error indication (REI-P) condition in the WIS receive data path. The error is reflected in register 2×EF04.3. 0: Normal operation. 1: Device forced into Rx REI-P condition.	0
8	FRC_RX_REIL	RW	Force a line remote error indication (REI-L) condition in the WIS receive data path. The error is reflected in register 2×EF04.4. 0: Normal operation. 1: Device forced into Rx REI-L condition.	0
7	FRC_RX_SEF	RW	Force a severely errored frame (SEF) condition in the WIS receive data path. 0: Normal operation. 1: Device forced into Rx SEF condition.	0
6	FRC_RX_LOF	RW	Force a loss of frame (LOF) condition in the WIS receive data path. 0: Normal operation. 1: Device forced into Rx LOF condition.	0
5	FRC_RX_B1	RW	Force a PMTICK B1 BIP error condition (B1NZ) in the WIS receive data path. 0: Normal operation. 1: Device forced into PMTICK B1 BIP error condition.	0
4	FRC_RX_B2	RW	Force a PMTICK B2 BIP error condition (B2NZ) in the WIS receive data path. 0: Normal operation. 1: Device forced into PMTICK B2 BIP error condition.	0
3	FRC_RX_B3	RW	Force a PMTICK B3 BIP error condition (B3NZ) in the WIS receive data path. 0: Normal operation. 1: Device forced into PMTICK B3 BIP error condition.	0

**Table 148 • EWIS\_RX\_ERR\_FRC2: E-WIS Rx Error Force Control 2 (2×EC31) (continued)**

Bit	Name	Access	Description	Default
2	FRC_RX_LCDP	RW	Force a loss of code-group delineation (LCD-P) defect in the WIS receive data path. 0: Normal operation. 1: Device forced into Rx LCD-P condition.	0
1	FRC_RX_REIL_NZ	RW	Force a far-end line BIP error condition (far-end B2NZ) in the WIS receive data path. The error is reflected in register 2×EF04.2. 0: Normal operation. 1: Device forced into Rx far-end line BIP error condition.	0
0	FRC_RX_REIP_NZ	RW	Force a far-end path BIP error condition (far-end B3NZ) in the WIS receive data path. The error is reflected in register 2×EF04.1. 0: Normal operation. 1: Device forced into Rx far-end path BIP error condition.	0

**Table 149 • EWIS\_MODE\_CTRL: E-WIS Mode Control (2×EC40)**

Bit	Name	Access	Description	Default
15:13	Reserved	RO	Reserved.	0
12	REI_MODE	RW	Selects REI extraction from the M0/M1 bytes in the WIS receive data path. 0: SONET mode enabled. Uses M1 only. 1: SDH mode enabled. Uses M0 and M1.	0
11	SDH_RX_MODE	RW	Selects H1/H2 pointer processing. 0: SONET mode. 1: SDH mode.	0
10:9	Reserved	RW	Factory test only; do not modify this bit group.	0
8	RX_ERDI_MODE	RW	Selects ERDI-P/RDI-P extraction from the G1 byte in the WIS received data. 0: RDI-P is reported in bit 5, bits 6 and 7 are unused. 1: ERDI is reported in bits 5-7. 101 indicates far-end AIS-P. 110 indicates far-end UNEQ-P. 010 indicates far-end PLM-P.	1
7:0	C2_EXP	RW	Expected C2 receive octet. A PLM-P alarm is generated if this octet value is not received.	0×1A

**Table 150 • Factory Test Register (2×EC41)**

Bit	Name	Access	Description	Default
15:0	Reserved	RO	Factory test only; do not modify this bit group.	0

**Table 151 • EWIS\_PRBS31\_ANA\_CTRL: E-WIS PRBS31 Analyzer Control (2×EC50)**

Bit	Name	Access	Description	Default
15:2	Reserved	RO	Reserved.	0
1	PRBS31_FRC_ER R	RW	Inject a single bit error into the WIS PRBS31 pattern checker. A single bit error results in the error counter incrementing by 3 (one error for each tap of the checker). 0: Normal operation. 1: Inject error.	0
0	PRBS31_FRC_SAT	RWSC	Force the PRBS31 pattern error counter to a value of 65528. This can be useful for testing the saturating feature of the counter. 0: Normal operation. 1: Force the PRBS31 error counter to a value of 65528. Forcing the counter to 65528 through this bit has no effect on register 2×EC51.1.	0

**Table 152 • EWIS\_PRBS31\_ANA\_STAT: E-WIS PRBS31 Analyzer Status (2×EC51)**

Bit	Name	Access	Description	Default
15:2	Reserved	RO	Reserved.	0
1	PRBS31_ERR	RO	Status bit indicating if the WIS PRBS31 error counter is non-zero. 0: Counter is zero. 1: Counter is non-zero. When the WIS PRBS31 analyzer is disabled, this bit might still be on. When the analyzer is re-enabled, this bit is cleared. If needed, the device reset can be used to clear the status.	0
0	PRBS31_ANA_STAT E	RO	Indicates when the Rx WIS PRBS31 pattern checker is synchronized to the incoming data. 0: PRBS31 pattern checker is not synchronized to the data. PRBS31 error counter value is not valid. 1: PRBS31 pattern checker is synchronized to the data.	0

**Table 153 • EWIS\_PMTICK\_CTRL: E-WIS Performance Monitor Control (2×EC60)**

Bit	Name	Access	Description	Default
15:3	PMTICK_DUR	RW	Sets the interval for updating the PMTICK error counters when the PMTICK_SRC bit is 1. The value represents the number of 125 μs increments between PMTICK events. 0: Undefined. 1: Undefined. 2: 250 μs. --- 8: 1 ms. 8000: 1 second 8191: 1.024 seconds	0×1F40
2	PMTICK_ENA	RW	Enables the PMTICK counters to be updated on a PMTICK event. The source of the PMTICK event is determined by the PMTICK_SRC bit. 0: Disable. 1: Enable.	0
1	PMTICK_SRC	RW	Selects how the PMTICK counters are updated. The PMTICK counters are updated with the selected source only if the PMTICK enable bit is set. 0: PMTICK counters updated on a rising edge of the PMTICK pin. 1: PMTICK counters updated when the PMTICK counter reaches its terminal count.	1
0	PMTICK_FRC	RWSC	Force the PMTICK counters to update, regardless of the PMTICK_ENA or PMTICK_SRC settings. 0: Normal operation. 1: Forces PMTICK event.	0

**Table 154 • EWIS\_CNT\_CFG: E-WIS Counter Configuration (2×EC61)**

Bit	Name	Access	Description	Default
15:12	Reserved	RO	Reserved	0
11	B1_BLK_MODE	RW	Enables block mode (increment once for each errored frame) counting for the B1 BIP PMTICK counter. 0: Bit mode 1: Block mode	0
10	B2_BLK_MODE	RW	Enables block mode (increment once for each errored frame) counting for the B2 BIP PMTICK counter 0: Bit mode 1: Block mode	0
9	B3_BLK_MODE	RW	Enables block mode (increment once for each errored frame) counting for the B3 BIP PMTICK counter 0: Bit mode 1: Block mode	0

**Table 154 • EWIS\_CNT\_CFG: E-WIS Counter Configuration (2×EC61) (continued)**

Bit	Name	Access	Description	Default
8:6	Reserved	RO	Reserved	0
5	REIP_BLK_MODE	RW	Enables block mode (increment once for each errored frame) counting for the REI-P (far-end B3 error count in the G1 byte) PMTICK counter 0: Bit mode 1: Block mode	0
4	REIL_BLK_MODE	RW	Enables block mode (increment once for each errored frame) counting for the REI-L (far-end B2 error count in the M0/M1 byte) PMTICK counter 0: Bit mode 1: Block mode	0
3:0	Reserved	RO	Reserved	0

**Table 155 • EWIS\_CNT\_STAT: E-WIS Counter Status (2×EC62)**

Bit	Name	Access	Description	Default
15:3	Reserved	RO	Reserved	0
2	REIP_CNT_STAT	RO	Status bit indicating if the REI-P (far-end B3) PMTICK counter is non-zero 0: Counter is zero 1: Counter is non-zero Counter is not impacted by FRC_RX_REIP or FRC_RX_REIP_NZ.	0
1	REIL_CNT_STAT	RO	Status bit indicating if the REI-L (far-end B2) PMTICK counter is non-zero 0: Counter is zero 1: Counter is non-zero Counter is not impacted by FRC_RX_REIL or FRC_RX_REIL_NZ.	0
0	Reserved	RO	Factory test only; do not modify this bit	0

**Table 156 • EWIS\_REIP\_CNT1: E-WIS P-REI Counter 1 (MSW) (2×EC80)**

Bit	Name	Access	Description	Default
15:0	REIP_ERR_CNT_MS W	RO	PMTICK statistical error count of the far-end B3 errors (reported in the G1 byte). 16 MSB are in this register, 16 LSB are in the next register. The count is updated only on a PMTICK event. The counter saturates to all ones.	0

**Table 157 • EWIS\_REIP\_CNT0: E-WIS P-REI Counter 0 (LSW) (2×EC81)**

Bit	Name	Access	Description	Default
15:0	REIP_ERR_CNT_LS W	RO	PMTICK statistical error count of the far-end B3 errors (reported in the G1 byte). 16 LSB are in this register, 16 MSB are in the previous register. The count is updated only on a PMTICK event. The counter saturates to all ones.	0

**Table 158 • EWIS\_REIL\_CNT1: E-WIS L-REI Counter 1 (MSW) (2×EC90)**

Bit	Name	Access	Description	Default
15:0	REIL_ERR_CNT_MS W	RO	PMTICK statistical error count of the far-end B2 errors (reported in the M0/M1 bytes). 16 MSB are in this register, 16 LSB are in the next register. The count is updated only on a PMTICK event. The counter saturates to all ones.	0

**Table 159 • EWIS\_REIL\_CNT0: E-WIS L-REI Counter 0 (LSW) (2×EC91)**

Bit	Name	Access	Description	Default
15:0	REIL_ERR_CNT_LS W	RO	PMTICK statistical error count of the far-end B2 errors (reported in the M0/M1 bytes). 16 LSB are in this register, 16 MSB are in the previous register. The count is updated only on a PMTICK event. The counter saturates to all ones.	0

**Table 160 • Factory Test Register (2×ECA0)**

Bit	Name	Access	Description	Default
15:7	Reserved	RO	Factory test only; do not modify this bit group	0
6:0	Reserved	RO	Factory test only; do not modify this bit group	0

**Table 161 • EWIS\_B1\_ERR\_CNT1: E-WIS S-BIP Error Counter 1 (MSW) (2×ECB0)**

Bit	Name	Access	Description	Default
15:0	B1_ERR_CNT_MS W	RO	PMTICK statistical error count of the B1 BIP errors. 16 MSB are in this register, 16 LSB are in the next register. The count is updated only on a PMTICK event. The counter saturates to all ones.	0



**Table 162 • EWIS\_B1\_ERR\_CNT0: E-WIS S-BIP Error Counter 0 (LSW) (2×ECB1)**

Bit	Name	Access	Description	Default
15:0	B1_ERR_CNT_LS W	RO	PMTICK statistical error count of the B1 BIP errors. 16 LSB are in this register, 16 MSB are in the previous register. The count is updated only on a PMTICK event. The counter saturates to all ones.	0

**Table 163 • EWIS\_B2\_ERR\_CNT1: E-WIS L-BIP Error Counter 1 (MSW) (2×ECB2)**

Bit	Name	Access	Description	Default
15:0	B2_ERR_CNT_MS W	RO	PMTICK statistical error count of the B2 BIP errors. 16 MSB are in this register, 16 LSB are in the next register. The count is updated only on a PMTICK event. The counter saturates to all ones.	0

**Table 164 • EWIS\_B2\_ERR\_CNT0: E-WIS L-BIP Error Counter 0 (LSW) (2×ECB3)**

Bit	Name	Access	Description	Default
15:0	B2_ERR_CNT_LSW	RO	PMTICK statistical error count of the B2 BIP errors. 16 LSB are in this register, 16 MSB are in the previous register. The count is updated only on a PMTICK event. The counter saturates to all ones.	0

**Table 165 • EWIS\_B3\_ERR\_CNT1: E-WIS P-BIP Error Counter 1 (MSW) (2×ECB4)**

Bit	Name	Access	Description	Default
15:0	B3_ERR_CNT_MSW	RO	PMTICK statistical error count of the B3 BIP errors. 16 MSB are in this register, 16 LSB are in the next register. The count is updated only on a PMTICK event. The counter saturates to all ones.	0

**Table 166 • EWIS\_B3\_ERR\_CNT0: E-WIS P-BIP Error Counter 0 (LSW) (2×ECB5)**

Bit	Name	Access	Description	Default
15:0	B3_ERR_CNT_LS W	RO	PMTICK statistical error count of the B3 BIP errors. 16 LSB are in this register, 16 MSB are in the previous register. The count is updated only on a PMTICK event. The counter saturates to all ones.	0

**Table 167 • Factory Test Register (2×ED00–ED08)**

Bit	Name	Access	Description	Default
15:0	Reserved	RO	Factory test only; do not modify this bit group	0

**Table 168 • EWIS\_RXTX\_CTRL: E-WIS Rx to Tx Control (2×EE00)**

Bit	Name	Access	Description	Default
15:7	Reserved	RO	Reserved.	0
6	RXAISL_ON_LOP C	RW	Selects if an LOPC condition contributes to the Rx AIS-L alarm. 0: LOPC condition does not cause the AIS-L alarm to be set. 1: LOPC condition causes the AIS-L alarm to be set.	0
5	RXAISL_ON_LOS	RW	Selects if an LOS condition contributes to the Rx AIS-L alarm. 0: LOS condition does not cause the AIS-L alarm to be set. 1: LOS condition causes the AIS-L alarm to be set.	0
4	RXAISL_ON_LOF	RW	Selects if an LOF condition contributes to the Rx AIS-L alarm. 0: LOF condition does not cause the AIS-L alarm to be set. 1: LOF condition causes the AIS-L alarm to be set.	0
3	TXRDIL_ON_LOP C	RW	Selects if a RDI-L is reported in the Tx frame's K2 byte when an LOPC condition is detected. 0: RDI-L is not reported when LOPC is detected. 1: RDI-L is reported when LOPC is detected.	0
2	TXRDIL_ON_LOS	RW	Selects whether or not RDI-L is reported in the Tx frame's K2 byte when an LOS condition is detected. 0: RDI-L is not reported when LOS is detected. 1: RDI-L is reported when LOS is detected.	0
1	TXRDIL_ON_LOF	RW	Selects whether or not RDI-L is reported in the Tx frame's K2 byte when an LOF condition is detected. 0: RDI-L is not reported when LOF is detected. 1: RDI-L is reported when LOF is detected.	0
0	TXRDIL_ON_AISL	RW	Selects whether or not RDI-L is reported in the Tx frame's K2 byte when a Rx AIS-L condition is detected. 0: RDI-L is not reported when a Rx AIS-L condition is detected. 1: RDI-L is reported when a Rx AIS-L condition is detected.	0

**Table 169 • EWIS\_PEND1: E-WIS Interrupt Pending 1 (2×EF00)**

Bit	Name	Access	Description	Default
15	Reserved	RO	Reserved.	0
14	MSTCODE2_PEND	ROCR	Interrupt pending. MSTCODE[2] input pin has changed state since this register was last read. The MSTCODE[2] pin status is reported in 1×E607.15. 0: MSTCODE[2] pin has not changed state since last read of this register. 1: MSTCODE[2] pin has changed state.	0
13	MSTCODE1_PEND	ROCR	Interrupt pending. MSTCODE[1] input pin has changed state since this register was last read. The MSTCODE[1] pin status is reported in 1×E607.14. 0: MSTCODE[1] pin has not changed state since last read of this register. 1: MSTCODE[1] pin has changed state.	0
12	MSTCODE0_PEND	ROCR	Interrupt pending. MSTCODE[0] input pin has changed state since this register was last read. The MSTCODE[1] pin status is reported in 1×E607.13. 0: MSTCODE[0] pin has not changed state since last read of this register. 1: MSTCODE[0] pin has changed state.	0
11	SEF_PEND	ROCR	Interrupt pending. SEF has changed state since this register was last read. 0: SEF condition has not changed state. 1: SEF condition has changed state.	0
10	FEPLMP_LCDP_PEND	ROCR	Interrupt pending. Far-end path label mismatch (PLM-P)/loss of code-group delineation (LCD-P) condition has changed state since this register was last read. 0: PLM-P/LCD-P has not changed state. 1: PLM-P/LCD-P condition has changed state.	0
9	FEAISP_LOPP_PEND	ROCR	Interrupt pending. Far-end path alarm indication signal (AIS-P)/path loss of pointer (LOP) condition has changed state since this register was last read. 0: Far-end AIS-P/LOP-P condition has not changed state. 1: Far-end AIS-P/LOP-P condition has changed state.	0
8	Reserved	RO	Reserved	0
7	LOF_PEND	ROCR	Interrupt pending. Loss of frame (LOF) condition has changed state since this register was last read. 0: LOF condition has not changed state. 1: LOF condition has changed state.	0

**Table 169 • EWIS\_PEND1: E-WIS Interrupt Pending 1 (2×EF00) (continued)**

Bit	Name	Access	Description	Default
6	LOS_PEND	ROCR	Interrupt pending. Loss of signal (LOS) condition has changed state since this register was last read. This bit does not assert if LOPC is active at the time LOS changes state. 0: LOS condition has not changed state. 1: LOS condition has changed state.	0
5	RDIL_PEND	ROCR	Interrupt pending. Line remote defect indication (RDI-L) has changed state since this register was last read. 0: RDI-L condition has not changed state. 1: RDI-L condition has changed state.	0
4	AI SL_PEND	ROCR	Interrupt pending. Line alarm indication signal (AIS-L) has changed state since this register was last read. This bit does not assert if LOPC, LOS, LOF, or SEF are asserted at the time AIS-L changes state. 0: AIS-L condition has not changed state. 1: AIS-L condition has changed state.	0
3	LC DP_PEND	ROCR	Interrupt pending. Loss of code-group delineation (LCD-P) has changed state since this register was last read. This bit does not assert if AIS-L, AIS-P, UNEQ-P, or PLM-P are asserted at the time LCD-P changes state. 0: LCD-P condition has not changed state. 1: LCD-P condition has changed state.	0
2	PLMP_PEND	ROCR	Interrupt pending. Path label mismatch (PLM-P) has changed state since this register was last read. This bit does not assert if LOP-P or AIS-P are asserted at the time PLM-P changes state. 0: PLM-P condition has not changed state. 1: PLM-P condition has changed state.	0
1	AISP_PEND	ROCR	Interrupt pending. Path alarm indication signal (AIS-P) has changed state since this register was last read. This bit does not assert if LOPC, LOS, SEF, LOF, or AIS-L are asserted at the time AIS-P changes state. 0: AIS-P condition has not changed state. 1: AIS-P condition has changed state.	0
0	LOPP_PEND	ROCR	Interrupt pending. Path loss of pointer (LOP-P) has changed state since this register was last read. 0: LOP-P condition has not changed state. 1: LOP-P condition has changed state.	0

**Table 170 • EWIS\_MASKA\_1: E-WIS Interrupt Mask A 1 (2×EF01)**

Bit	Name	Access	Description	Default
15	Reserved	RO	Reserved	0
14	MSTCODE2_MASKA	RW	Enables propagation of MSTCODE2_PEND to the WIS_INTA pin 0: Disable 1: Enable	0
13	MSTCODE1_MASKA	RW	Enables propagation of MSTCODE1_PEND to the WIS_INTA pin 0: Disable 1: Enable	0
12	MSTCODE0_MASKA	RW	Enables propagation of MSTCODE0_PEND to the WIS_INTA pin 0: Disable 1: Enable	0
11	SEF_MASKA	RW	Enables propagation of SEF_PEND to the WIS_INTA pin 0: Disable 1: Enable	0
10	FEPLMP_LCDP_MASKA	RW	Enables propagation of FEPLMP_LCDP_PEND to the WIS_INTA pin 0: Disable 1: Enable	0
9	FEAISP_LOPP_MASKA	RW	Enables propagation of FEAISP_LOPP_PEND to the WIS_INTA pin 0: Disable 1: Enable	0
8	Reserved	RO	Reserved	0
7	LOF_MASKA	RW	Enables propagation of LOF_PEND to the WIS_INTA pin 0: Disable 1: Enable	0
6	LOS_MASKA	RW	Enables propagation of LOS_PEND to the WIS_INTA pin 0: Disable 1: Enable	0
5	RDIL_MASKA	RW	Enables propagation of RDIL_PEND to the WIS_INTA pin 0: Disable 1: Enable	0
4	AISL_MASKA	RW	Enables propagation of AISL_PEND to the WIS_INTA pin 0: Disable 1: Enable	0
3	LCDP_MASKA	RW	Enables propagation of LCDP_PEND to the WIS_INTA pin 0: Disable 1: Enable	0

**Table 170 • EWIS\_MASKA\_1: E-WIS Interrupt Mask A 1 (2×EF01) (continued)**

Bit	Name	Access	Description	Default
2	PLMP_MASKA	RW	Enables propagation of PLMP_PEND to the WIS_INTA pin 0: Disable 1: Enable	0
1	AISP_MASKA	RW	Enables propagation of AISP_PEND to the WIS_INTA pin 0: Disable 1: Enable	0
0	LOPP_MASKA	RW	Enables propagation of LOPP_PEND to the WIS_INTA pin 0: Disable 1: Enable	0

**Table 171 • EWIS\_MASKB\_1: E-WIS Interrupt Mask B 1 (2×EF02)**

Bit	Name	Access	Description	Default
15	Reserved	RO	Reserved	0
14	MSTCODE2_MASKB	RW	Enables propagation of MSTCODE2_PEND to the WIS_INTB pin 0: Disable 1: Enable	0
13	MSTCODE1_MASKB		Enables propagation of MSTCODE1_PEND to the WIS_INTB pin 0: Disable 1: Enable	
12	MSTCODE0_MASKB		Enables propagation of MSTCODE0_PEND to the WIS_INTB pin 0: Disable 1: Enable	
11	SEF_MASKB	RW	Enables propagation of SEF_PEND to the WIS_INTB pin 0: Disable 1: Enable	0
10	FEPLMP_LCDP_MAS KB	RW	Enables propagation of FEPLMP_LCDP_PEND to the WIS_INTB pin 0: Disable 1: Enable	0
9	FEAISP_LOPP_MASK B	RW	Enables propagation of FEAISP_LOPP_PEND to the WIS_INTB pin 0: Disable 1: Enable	0
8	Reserved	RO	Reserved	0
7	LOF_MASKB	RW	Enables propagation of LOF_PEND to the WIS_INTB pin 0: Disable 1: Enable	0

**Table 171 • EWIS\_MASKB\_1: E-WIS Interrupt Mask B 1 (2×EF02) (continued)**

Bit	Name	Access	Description	Default
6	LOS_MASKB	RW	Enables propagation of LOS_PEND to the WIS_INTB pin 0: Disable 1: Enable	0
5	RDIL_MASKB	RW	Enables propagation of RDIL_PEND to the WIS_INTB pin 0: Disable 1: Enable	0
4	AISL_MASKB	RW	Enables propagation of AISL_PEND to the WIS_INTB pin 0: Disable 1: Enable	0
3	LCDP_MASKB	RW	Enables propagation of LCDP_PEND to the WIS_INTB pin 0: Disable 1: Enable	0
2	PLMP_MASKB	RW	Enables propagation of PLMP_PEND to the WIS_INTB pin 0: Disable 1: Enable	0
1	AISP_MASKB	RW	Enables propagation of AISP_PEND to the WIS_INTB pin 0: Disable 1: Enable	0
0	LOPP_MASKB	RW	Enables propagation of LOPP_PEND to the WIS_INTB pin 0: Disable 1: Enable	0

**Table 172 • EWIS\_INTR\_STAT2: E-WIS Interrupt Status 2 (2×EF03)**

Bit	Name	Access	Description	Default
15:14	Reserved	RO	Reserved	0
13	TXLOL_STAT	RO	PMA CMU loss of lock status 0: No PMA CMU lock error 1: PMA CMU lock error	0
12	RXLOL_STAT	RO	PMA CRU loss of lock status 0: No PMA CRU lock error 1: PMA CRU lock error	0
11	LOPC_STAT	RO	Loss of optical carrier (LOPC) status 0: The LOPC input pin is deasserted 1: The LOPC input pin is asserted	0
10	UNEQP_STAT	RO	Unequipped path (UNEQ-P) status 0: UNEQ-P is deasserted 1: UNEQ-P is asserted	0
9	FEUNEQP_STAT	RO	Far-end unequipped path (UNEQ-P) status 0: Far-end UNEQ-P is deasserted 1: Far-end UNEQ-P is asserted	0

**Table 172 • EWIS\_INTR\_STAT2: E-WIS Interrupt Status 2 (2×EF03) (continued)**

Bit	Name	Access	Description	Default
8	FERDIP_STAT	RO	Far-end path remote defect identifier (RDI-P) status 0: Far-end RDI-P is deasserted 1: Far-end RDI-P is asserted	0
7	B1_NZ_STAT	RO	PMTICK B1 BIP (B1_ERR_CNT) counter status 0: B1_ERR_CNT is zero 1: B1_ERR_CNT is non-zero	0
6	B2_NZ_STAT	RO	PMTICK B2 BIP (B2_ERR_CNT) counter status 0: B2_ERR_CNT is zero 1: B2_ERR_CNT is non-zero	0
5	B3_NZ_STAT	RO	PMTICK B3 BIP (B3_ERR_CNT) counter status 0: B3_ERR_CNT is zero 1: B3_ERR_CNT is non-zero	0
4	REIL_STAT	RO	Line remote error indication (REI-L) value status 0: The REI-L value in the last received frame reported no errors 1: The REI-L value in the last received frame reported errors	0
3	REIP_STAT	RO	Path remote error indication (REI-P) value status 0: The REI-P value in the last received frame reported no errors 1: The REI-P value in the last received frame reported errors  <b>Note:</b> When an invalid REI-P value of 9 to 15 is received, the REI-P status bit will be triggered, even though the REI-P counter is not incremented.	0
2	REIL_NZ_STAT	RO	PMTICK REI-L (REIL_ERR_CNT) counter status 0: REIL_ERR_CNT is zero 1: REIL_ERR_CNT is non-zero	0
1	REIP_NZ_STAT	RO	PMTICK REI-P (REIP_ERR_CNT) counter status 0: REIP_ERR_CNT is zero 1: REIP_ERR_CNT is non-zero	0
0	HIGH_BER_STAT	RO	PCS high bit error rate (BER) status 0: No high BER 1: The PCS block indicates a high bit error rate	0

**Table 173 • EWIS\_INTR\_PEND2: E-WIS Interrupt Pending 2 (2×EF04)**

Bit	Name	Access	Description	Default
15	Reserved	RO	Reserved.	0
14	PMTICK_PEND	ROCR	Interrupt pending. A PMTICK event (regardless of the source) has occurred since this register was last read. 0: A PMTICK event has not occurred. 1: A PMTICK event occurred.	0



**Table 173 • EWIS\_INTR\_PEND2: E-WIS Interrupt Pending 2 (2×EF04) (continued)**

Bit	Name	Access	Description	Default
13	TXLOL_PEND	ROCR	Interrupt pending. PMA CMU lock signal (TXLOL_STAT) has changed state since this register was last read. 0: TXLOL_STAT has not changed state. 1: TXLOL_STAT has changed state.	0
12	RXLOL_PEND	ROCR	Interrupt pending. PMA CRU lock signal (RXLOL_STAT) has changed state since this register was last read. 0: RXLOL_STAT has not changed state. 1: RXLOL_STAT has changed state.	0
11	LOPC_PEND	ROCR	Interrupt pending. Loss of optical carrier (LOPC) input pin (LOPC_STAT) has changed state since this register was last read. 0: LOPC_STAT has not changed state. 1: LOPC_STAT has changed state.	0
10	UNEQP_PEND	ROCR	Interrupt pending. Unequipped path (UNEQP_STAT) has changed state since this register was last read. This bit does not assert if LOP-P or AIS-P are asserted at the time UNEQP changes state. 0: UNEQP_STAT has not changed state. 1: UNEQP_STAT has changed state.	0
9	FEUNEQP_PEND	ROCR	Interrupt pending. Far-end unequipped path (FEUNEQP_STAT) has changed state since this register was last read. 0: FEUNEQP_STAT has not changed state. 1: FEUNEQP_STAT has changed state.	0
8	FERDIP_PEND	ROCR	Interrupt pending. Far-end path remote defect identifier (FERDIP_STAT) has changed state since this register was last read. 0: FERDIP_STAT has not changed state. 1: FERDIP_STAT has changed state.	0
7	B1_NZ_PEND	ROCR	Interrupt pending. PMTICK B1 error counter (B1_ERR_CNT) has changed from zero to a non-zero value since this register was last read. This bit does not assert if LOS or LOF are asserted at the time B1_NZ changes from 0 to 1. 0: B1_NZ_STAT has not changed from a 0 to 1 state. 1: B1_NZ_STAT has changed from a 0 to 1 state.	0
6	B2_NZ_PEND	ROCR	Interrupt pending. PMTICK B2 error counter (B2_ERR_CNT) has changed from zero to a non-zero value since this register was last read. This bit does not assert if AIS-L is asserted at the time B2_NZ changes from 0 to 1. 0: B2_NZ_STAT has not changed from a 0 to 1 state. 1: B2_NZ_STAT has changed from a 0 to 1 state.	0

**Table 173 • EWIS\_INTR\_PEND2: E-WIS Interrupt Pending 2 (2×EF04) (continued)**

Bit	Name	Access	Description	Default
5	B3_NZ_PEND	ROCR	Interrupt pending. PMTICK B3 error counter (B3_ERR_CNT) has changed from zero to a non-zero value since this register was last read. This bit does not assert if LOP-P or AIS-P are asserted at the time B3_NZ changes from 0 to 1. 0: B3_NZ_STAT has not changed from a 0 to 1 state. 1: B3_NZ_STAT has changed from a 0 to 1 state.	0
4	REIL_PEND	ROCR	Interrupt pending. REI-L changed from zero to non-zero. 0: REI-L has not received a non-zero value. 1: REI-L has received a non-zero value.	0
3	REIP_PEND	ROCR	Interrupt pending. REI-P changed from zero to non-zero. 0: REI-P has not received a non-zero value. 1: REI-P has received a non-zero value.	0
2	REIL_NZ_PEND	ROCR	Interrupt pending. PMTICK far-end B2 error counter (REIL_ERR_CNT) has changed from a zero to a non-zero value since this register was read. 0: REIL_NZ_STAT has not changed from a 0 to 1 state. 1: REIL_NZ_STAT has changed from a 0 to 1 state.	0
1	REIP_NZ_PEND	ROCR	Interrupt pending. PMTICK far-end B3 error counter (REIP_ERR_CNT) has changed from a zero to a non-zero value since this register was read. 0: REIP_NZ_STAT has changed from a 0 to 1 state. 1: REIP_NZ_STAT has changed from a 0 to 1 state.	0
0	HIGH_BER_PEND	ROCR	Interrupt pending. PCS high bit error rate (BER) condition has changed state since this register was read. 0: No change in PCS high BER condition. 1: PCS high BER condition has changed state.	0

**Table 174 • EWIS\_INTR\_MASKA2: E-WIS Interrupt Mask A 2 (2×EF05)**

Bit	Name	Access	Description	Default
15	Reserved	RO	Reserved	0
14	PMTICK_MASKA	RW	Enables propagation of PMTICK_PEND to the WIS_INTA pin 0: Disable 1: Enable	0

**Table 174 • EWIS\_INTR\_MASKA2: E-WIS Interrupt Mask A 2 (2×EF05) (continued)**

Bit	Name	Access	Description	Default
13	TXLOL_MASKA	RW	Enables propagation of TXLOL_PEND to the WIS_INTA pin 0: Disable 1: Enable	0
12	RXLOL_MASKA	RW	Enables propagation of RXLOL_PEND to the WIS_INTA pin 0: Disable 1: Enable	0
11	LOPC_MASKA	RW	Enables propagation of LOPC_PEND to the WIS_INTA pin 0: Disable 1: Enable	0
10	UNEQP_MASKA	RW	Enables propagation of UNEQP_PEND to the WIS_INTA pin 0: Disable 1: Enable	0
9	FEUNEQP_MASKA	RW	Enables propagation of FEUNEQP_PEND to the WIS_INTA pin 0: Disable 1: Enable	0
8	FERDIP_MASKA	RW	Enables propagation of FERDIP_PEND to the WIS_INTA pin 0: Disable 1: Enable	0
7	B1_NZ_MASKA	RW	Enables propagation of B1_NZ_PEND to the WIS_INTA pin 0: Disable 1: Enable	0
6	B2_NZ_MASKA	RW	Enables propagation of B2_NZ_PEND to the WIS_INTA pin 0: Disable 1: Enable	0
5	B3_NZ_MASKA	RW	Enables propagation of B3_NZ_PEND to the WIS_INTA pin 0: Disable 1: Enable	0
4	REIL_MASKA	RW	Enables propagation of REIL_PEND to the WIS_INTA pin 0: Disable 1: Enable	0
3	REIP_MASKA	RW	Enables propagation of REIP_PEND to the WIS_INTA pin 0: Disable 1: Enable	0
2	REIL_NZ_MASKA	RW	Enables propagation of REIL_NZ_PEND to the WIS_INTA pin 0: Disable 1: Enable	0

**Table 174 • EWIS\_INTR\_MASKA2: E-WIS Interrupt Mask A 2 (2×EF05) (continued)**

Bit	Name	Access	Description	Default
1	REIP_NZ_MASKA	RW	Enables propagation of REIP_NZ_PEND to the WIS_INTA pin 0: Disable 1: Enable	0
0	HIGH_BER_MASKA	RW	Enables propagation of HIGH_BER_PEND to the WIS_INTA pin 0: Disable 1: Enable	0

**Table 175 • EWIS\_INTR\_MASKB2: E-WIS Interrupt Mask B 2 (2×EF06)**

Bit	Name	Access	Description	Default
15	Reserved	RO	Reserved	0
14	PMTICK_MASKB	RW	Enables propagation of PMTICK_PEND to the WIS_INTB pin 0: Disable 1: Enable	0
13	TXLOL_MASKB	RW	Enables propagation of TXLOL_PEND to the WIS_INTB pin 0: Disable 1: Enable	0
12	RXLOL_MASKB	RW	Enables propagation of RXLOL_PEND to the WIS_INTB pin 0: Disable 1: Enable	0
11	LOPC_MASKB	RW	Enables propagation of LOPC_PEND to the WIS_INTB pin 0: Disable 1: Enable	0
10	UNEQP_MASKB	RW	Enables propagation of UNEQP_PEND to the WIS_INTB pin 0: Disable 1: Enable	0
9	FEUNEQP_MASKB	RW	Enables propagation of FEUNEQP_PEND to the WIS_INTB pin 0: Disable 1: Enable	0
8	FERDIP_MASKB	RW	Enables propagation of FERDIP_PEND to the WIS_INTB pin 0: Disable 1: Enable	0
7	B1_NZ_MASKB	RW	Enables propagation of B1_NZ_PEND to the WIS_INTB pin 0: Disable 1: Enable	0

**Table 175 • EWIS\_INTR\_MASKB2: E-WIS Interrupt Mask B 2 (2×EF06) (continued)**

Bit	Name	Access	Description	Default
6	B2_NZ_MASKB	RW	Enables propagation of B2_NZ_PEND to the WIS_INTB pin 0: Disable 1: Enable	0
5	B3_NZ_MASKB	RW	Enables propagation of B3_NZ_PEND to the WIS_INTB pin 0: Disable 1: Enable	0
4	REIL_MASKB	RW	Enables propagation of REIL_PEND to the WIS_INTB pin 0: Disable 1: Enable	0
3	REIP_MASKB	RW	Enables propagation of REIP_PEND to the WIS_INTB pin 0: Disable 1: Enable	0
2	REIL_NZ_MASKB	RW	Enables propagation of REIL_NZ_PEND to the WIS_INTB pin 0: Disable 1: Enable	0
1	REIP_NZ_MASKB	RW	Enables propagation of REIP_NZ_PEND to the WIS_INTB pin 0: Disable 1: Enable	0
0	HIGH_BER_MASKB	RW	Enables propagation of HIGH_BER_PEND to the WIS_INTB pin 0: Disable 1: Enable	0

**Table 176 • WIS Fault Control (2×EF07)**

Bit	Name	Access	Description	Default
15:11	Reserved	RW	Reserved	00111
10	WIS_FAULT_ON_FEPLM P	RW	1: Trigger WIS_FAULT 0: No trigger	0
9	WIS_FAULT_ON_FEAISP	RW	1: Trigger WIS_FAULT 0: No trigger	0
8	WIS_FAULT_ON_RDIL	RW	1: Trigger WIS_FAULT 0: No trigger	0
7	WIS_FAULT_ON_SEF	RW	1: Trigger WIS_FAULT 0: No trigger	1
6	WIS_FAULT_ON_LOF	RW	1: Trigger WIS_FAULT 0: No trigger	1
5	WIS_FAULT_ON_LOS	RW	1: Trigger WIS_FAULT 0: No trigger	1

**Table 176 • WIS Fault Control (2×EF07) (continued)**

Bit	Name	Access	Description	Default
4	WIS_FAULT_ON_AISL	RW	1: Trigger WIS_FAULT 0: No trigger	1
3	WIS_FAULT_ON_LCDP	RW	1: Trigger WIS_FAULT 0: No trigger	1
2	WIS_FAULT_ON_PLMP	RW	1: Trigger WIS_FAULT 0: No trigger	1
1	WIS_FAULT_ON_ASIP	RW	1: Trigger WIS_FAULT 0: No trigger	1
0	WIS_FAULT_ON_LOPP	RW	1: Trigger WIS_FAULT 0: No trigger	1

## 4.3 Device 3: PCS Registers

The following tables provide settings for the registers related to the PCS.

**Table 177 • PCS\_CTRL1: PCS Control 1 (3×0000)**

Bit	Name	Access	Description	Default
15	SOFT_RST	RWSC	Reset all MMDs 0: Normal operation 1: Reset	0
14	LPBK_G	RW	Enables PCS system loopback (loopback G) 0: Disable 1: Enable XFI outputs 0×00FF	0
13	SPEED_SEL_A	RO	PCS speed capability 0: Unspecified 1: Operates at 10 Gbps or above	1
12	Reserved	RO	Reserved (value always 0, writes ignored)	0
11	LOW_PWR	RW	Enter low power mode on all MMDs 0: Normal operation 1: Low power	0
10:7	Reserved	RO	Reserved (value always 0, writes ignored)	0
6	SPEED_SEL_B	RO	PCS speed capability 0: Unspecified 1: Operates at 10 Gbps or above	1
5:2	SPEED_SEL_C	RO	PCS speed selection 1xx: Reserved x1x: Reserved xx1x: Reserved 0001: Reserved 0000: 10 Gbps	0000
1:0	Reserved	RO	Reserved (value always 0, writes ignored)	0

**Table 178 • PCS\_STAT1: PCS Status 1 (3×0001)**

Bit	Name	Access	Description	Default
15:8	Reserved	RO	Reserved (ignore when read).	0
7	FAULT	RO	PCS fault status. Asserted when either the PCS FAULT_RX (3×0008.10) or PCS FAULT_TX (3×0008.11) is asserted. 0: No faults asserted. 1: Fault asserted.	0
6:3	Reserved	RO	Reserved (ignore when read).	0
2	RX_LNK_STAT	RO/LL	PCS receive link status. 0: Link down. 1: Link up.	1
1	LOW_PWR_ABILITY	RO	Low power mode support ability. 0: Not supported. 1: Supported.	1
0	Reserved	RO	Reserved (ignore when read).	0

**Table 179 • PCS\_DEVID1: PCS Device Identifier 1 (3×0002)**

Bit	Name	Access	Description	Default
15:0	DEV_ID_LSW	RO	Upper 16 bits of a 32-bit unique PCS device identifier. Bits 3-18 of the device manufacturer's OUI.	0×0007

**Table 180 • PCS\_DEVID2: PCS Device Identifier 2 (3×0003)**

Bit	Name	Access	Description	Default
15:0	DEV_ID_MSW	RO	Lower 16 bits of a 32-bit unique PCS device identifier. Bits 19-24 of the device manufacturer's OUI. Six-bit model number, and a four-bit revision number.	0×0400

**Table 181 • PCS\_SPEED: PCS Speed Capability (3×0004)**

Bit	Name	Access	Description	Default
15:1	Reserved	RO	Reserved for future speeds (value always 0, writes ignored)	0
0	RATE_ABILITY	RO	PCS rate capability 0: Not capable of 10 Gbps 1: Capable of 10 Gbps	1

**Table 182 • PCS\_DEVPKG1: PCS Devices in Package 1 (3×0005)**

Bit	Name	Access	Description	Default
15:6	Reserved	RO	Reserved.	0
5	DTE_XS_PRES	RO	Indicates whether DTE XS is present in the package. 0: Not present. 1: Present.	0
4	PHY_XS_PRES	RO	Indicates whether PHY XS is present in the package (this bit depends upon the IOMODESEL pin setting). 0: Not present. 1: Present.	1
3	PCS_PRES	RO	Indicates whether PCS is present in the package. 0: Not present. 1: Present.	1
2	WIS_PRES	RO	Indicates whether WIS is present in the package. 0: Not present. 1: Present.	1
1	PMD_PMA_PRES	RO	Indicates whether PMA/PMD is present in the package. 0: Not present. 1: Present.	1
0	CLS22_PRES	RO	Indicates whether Clause 22 registers are present in the package. 0: Not present. 1: Present.	0

**Table 183 • PCS\_DEVPKG2: PCS Devices in Package 2 (3×0006)**

Bit	Name	Access	Description	Default
15	VS2_PRES	RO	Vendor specific device 2 present 0: Not present 1: Present	0
14	VS1_PRES	RO	Vendor specific device 1 present 0: Not present 1: Present	0
13:0	Reserved	RO	Reserved	0

**Table 184 • PCS\_CTRL2: PCS Control 2 (3×0007)**

Bit	Name	Access	Description	Default
15:2	Reserved	RO	Reserved	0



**Table 184 • PCS\_CTRL2: PCS Control 2 (3×0007) (continued)**

Bit	Name	Access	Description	Default
1:0	PCS_MODE	RW	Indicates the PCS type selected 11: Reserved 10: 10GBASE-W PCS 01: Reserved 00: 10GBASE-R PCS	0

**Table 185 • PCS\_STAT2: PCS Status 2 (3×0008)**

Bit	Name	Access	Description	Default
15:14	DEV_PRESENCE	RO	Reflects the presence of a MMD responding at this address. 00: No device responding at this address. 01: No device responding at this address. 10: Device responding at this address. 11: No device responding at this address.	0
13:12	Reserved	RO	Reserved.	0
11	FAULT_TX	RO/LH	Indicates a fault condition on the transmit path. 0: No faults asserted. 1: Fault asserted. Set error triggers with 3×E600.1. Linked to 1E×9004.3. A read to either 1E×9004.3 or 3×0008.11 clears both bits if a fault condition no longer exists.	0
10	FAULT_RX	RO/LH	Indicates a fault condition on the receive path. 0: No faults asserted. 1: Fault asserted. Set error triggers with 3×E600.0. Linked to 1E×9003.3. A read to either 1E×9003.3 or 3×0008.10 clears both bits if a fault condition no longer exists.	0
9:3	Reserved	RO	Reserved.	0
2	BASE_W_ABILITY	RO	Device capability to support 10GBASE-W. 0: Not capable. 1: Capable.	1
1	BASE_X_ABILITY	RO	Device capability to support 10GBASE-X. 0: Not capable. 1: Capable.	0
0	BASE_R_ABILITY	RO	Device capability to support 10GBASE-R. 0: Not capable. 1: Capable.	1

**Table 186 • PCS\_PKGID1: PCS Package Identifier 1 (3×000E)**

Bit	Name	Access	Description	Default
15:0	PKG_ID_MSW	RO	Upper 16 bits of a 32-bit unique PCS package identifier. Bits 3-18 of the device manufacturer's OUI.	0

**Table 187 • PCS\_PKGID2: PCS Package Identifier 2 (3×000F)**

Bit	Name	Access	Description	Default
15:0	PKG_ID_LSW	RO	Lower 16 bits of a 32-bit unique PCS package identifier. Bits 19-24 of the device manufacturer's OUI. Six-bit model number, and a four-bit revision number.	0

**Table 188 • PCS\_10GBASEX\_STAT: PCS 10G BASE-X Status (3×0018)**

Bit	Name	Access	Description	Default
15:0	BASE_X_STAT	RO	This device does not implement 10GBASE-X.	0

**Table 189 • PCS\_10GBASEX\_CTRL: PCS 10G BASE-X Control (3×0019)**

Bit	Name	Access	Description	Default
15:0	BASE_X_CTRL	RO	This device does not implement 10GBASE-X.	0

**Table 190 • PCS\_10GBASER\_STAT1: PCS 10G BASE-R Status 1 (3×0020)**

Bit	Name	Access	Description	Default
15:13	Reserved	RO	Reserved.	0
12	BASE_R_RXLCK_STAT	RO	10GBASE-R receive link status. This does not apply during PCS pattern testing. 0: Link down. 1: Link up. <b>Note:</b> Receive link status reflects BLOCK_LOCK and not HIGH_BER.	0
11:3	Reserved	RO	Reserved.	0
2	PRBS31_ABILITY	RO	PCS PRBS31 pattern test capability. 0: Not capable. 1: Capable.	1
1	HIGH_BER	RO	10GBASE-R PCS high BER status. This does not apply during PCS pattern testing. 0: High BER deasserted. 1: High BER asserted.	0
0	BLOCK_LOCK	RO	10GBASE-R PCS block lock status. This does not apply during PCS pattern testing. 0: Not locked. 1: Locked.	0

**Table 191 • PCS\_10GBASER\_STAT2: PCS 10G BASE-R Status 2 (3×0021)**

Bit	Name	Access	Description	Default
15	BLOCK_LOCK_LATCHED	RO/LL	Latched block lock status. 0: 10GBASE-R PCS does not have block lock. 1: 10GBASE-R PCS has block lock.	1
14	HIGH_BER_LATCHED	RO/LH	Latched high BER status. 0: 10GBASE-R PCS has not reported a high BER. 1: 10GBASE-R PCS has reported a high BER.	0
13:8	BER_CNT	ROCR	Saturating (non-rollover) clear on read BER counter. This does not apply during PCS pattern testing.	0
7:0	ERR_BLK_CNT	ROCR	Saturating (non-rollover) clear on read errored block counter. This does not apply during PCS pattern testing.	0

**Table 192 • PCS\_SEEDA3: PCS Test Pattern Seed A 3 (3×0022)**

Bit	Name	Access	Description	Default
15:0	TSTPAT_SEEDA_15_0	RW	Bits 15:0 of the 58-bit seed A test pattern. Used during PCS pseudo-random test.	0

**Table 193 • PCS\_SEEDA2: PCS Test Pattern Seed A 2 (3×0023)**

Bit	Name	Access	Description	Default
15:0	TSTPAT_SEEDA_31_16	RW	Bits 31:16 of the 58-bit seed A test pattern. Used during PCS pseudo-random test.	0

**Table 194 • PCS\_SEEDA1: PCS Test Pattern Seed A 1 (3×0024)**

Bit	Name	Access	Description	Default
15:0	TSTPAT_SEEDA_47_32	RW	Bits 47:32 of the 58-bit seed A test pattern. Used during PCS pseudo-random test.	0

**Table 195 • PCS\_SEEDA0: PCS Test Pattern Seed A 0 (3×0025)**

Bit	Name	Access	Description	Default
15:10	Reserved	RO	Reserved	0
9:0	TSTPAT_SEEDA_57_48	RW	Bits 57:48 of the 58-bit seed A test pattern. Used during PCS pseudo-random test.	0

**Table 196 • PCS\_SEEDB3: PCS Test Pattern Seed B 3 (3×0026)**

Bit	Name	Access	Description	Default
15:0	TSTPAT_SEEDB_15_0	RW	Bits 15:0 of the 58-bit seed B test pattern. Used during PCS pseudo-random test.	0

**Table 197 • PCS\_SEEDB2: PCS Test Pattern Seed B 2 (3×0027)**

Bit	Name	Access	Description	Default
15:0	TSTPAT_SEEDB_31_16	RW	Bits 31:16 of the 58-bit seed B test pattern. Used during PCS pseudo-random test.	0

**Table 198 • PCS\_SEEDB1: PCS Test Pattern Seed B 1 (3×0028)**

Bit	Name	Access	Description	Default
15:0	TSTPAT_SEEDB_47_32	RW	Bits 47:32 of the 58-bit seed B test pattern. Used during PCS pseudo-random test.	0

**Table 199 • PCS\_SEEDB0: PCS Test Pattern Seed B 0 (3×0029)**

Bit	Name	Access	Description	Default
15:10	Reserved	RO	Reserved	0
9:0	TSTPAT_SEEDB_57_48	RW	Bits 57:48 of the 58-bit seed B test pattern. Used during PCS pseudo-random test.	0

**Table 200 • PCS\_TSTPAT\_CTRL: PCS Test Pattern Control (3×002A)**

Bit	Name	Access	Description	Default
15:6	Reserved	RO	Reserved	0
5	PCS_PRBS31_ANAL	RW	Enables PRBS31 test pattern analysis 0: Disable 1: Enable	0
4	PCS_PRBS31_GEN	RW	Enables PRBS31 test pattern generation 0: Disable 1: Enable	0
3	PCS_TSTPAT_GEN	RW	Enables PCS test pattern generator 0: Disable 1: Enable	0
2	PCS_TSTPAT_ANA	RW	Enables PCS test pattern analyzer 0: Disable 1: Enable	0

**Table 200 • PCS\_TSTPAT\_CTRL: PCS Test Pattern Control (3×002A) (continued)**

Bit	Name	Access	Description	Default
1	PCS_TSTPAT_SEL	RW	Selects which test pattern to be used during the PCS_TSTPAT_GEN/ANA 0: Pseudo-Random 1: Square Wave (generation only)	0
0	PCS_TSTDAT_SEL	RW	Data to be sent during the pseudo-random pattern test after the loading of seed A or seed B 0: 64-bit encoding for 2 local fault ordered sets 1: 64 zeros	0

**Table 201 • PCS\_TSTPAT\_CNT: PCS Test Pattern Error Counter (3×002B)**

Bit	Name	Access	Description	Default
15:0	Test error counter	ROCR	Clear on read test pattern error counter. A 32-bit version of this counter is available in 3×8007-3×8008. This counter is a saturating counter.	0

**Table 202 • PCS\_USRPAT0: PCS User Test Pattern 0 (3×8000)**

Bit	Name	Access	Description	Default
15:0	TSTPAT_USR_15_0	RW	Bits 15:0 of the 64-bit user pattern to be sent instead of local fault ordered sets during pseudo-random testing. Active when 3×8005.0 is asserted.	0

**Table 203 • PCS\_USRPAT1: PCS User Test Pattern 1 (3×8001)**

Bit	Name	Access	Description	Default
15:0	TSTPAT_USR_31_16	RW	Bits 31:16 of the 64-bit user pattern to be sent instead of local fault ordered sets during pseudo-random testing. Active when 3×8005.0 is asserted.	0

**Table 204 • PCS\_USRPAT2: PCS User Test Pattern 2 (3×8002)**

Bit	Name	Access	Description	Default
15:0	TSTPAT_USR_47_32	RW	Bits 47:22 of the 64-bit user pattern to be sent instead of local fault ordered sets during pseudo-random testing. Active when 3×8005.0 is asserted.	0

**Table 205 • PCS\_USRPAT3: PCS User Test Pattern 3 (3×8003)**

Bit	Name	Access	Description	Default
15:0	TSTPAT_USR_63_48	RW	Bits 63:48 of the 64-bit user pattern to be sent instead of local fault ordered sets during pseudo-random testing. Active when 3×8005.0 is asserted	0

**Table 206 • PCS\_SQPW\_CTRL: PCS Square Wave Pulse Width Control (3×8004)**

Bit	Name	Access	Description	Default
15:4	Reserved	RO	Reserved	0
3:0	SQ_WV_PW	RW	Pulse width of the generated square wave test pattern. This is the number of consecutive low bit times and the number of consecutive high bit times. Only values of 4 through 11 bits are valid.	0

**Table 207 • PCS\_CFG1: PCS Configuration 1 (3×8005)**

Bit	Name	Access	Description	Default
15:11	Reserved	RO	Reserved	0
10	DSCR_DIS	RW	Disable Rx block descrambler 0: Enable 1: Disable	0
9	SCR_DIS	RW	Disable Tx block scrambler 0: Enable 1: Disable	0
8	PCS_XGMII_SRC	RW	Select between XGXS and external XGMII as the source of data for the PCS 0: XGXS source 1: External XGMII source	0
7	PHYXS_XGMII_SRC	RW	Select between PCS and external XGMII as the source of data for the XGXS 0: PCS source 1: External XGMII source	0
6	XGMII_OE	RW	External XGMII output enable 0: Disable 1: Enable	0
5	Reserved	RW	Factory test only; do not modify this bit	0
4	Reserved	RW	Factory test only; do not modify this bit	0
3	LPBK_F	RW	Enables loopback F (PCS network loopback) 0: Disable 1: Enable	0
2	LPBK_E	RW	Enables loopback E (PCS system loopback) 0: Disable 1: Enable	0

**Table 207 • PCS\_CFG1: PCS Configuration 1 (3×8005) (continued)**

Bit	Name	Access	Description	Default
1	Reserved	RO	Reserved	0
0	USR_PAT_EN	RW	Selects the user test pattern in 3×8000 to 3×8003 for pseudo-random test 0: Standard test pattern 1: User test pattern	0

**Table 208 • PCS\_ERR\_CNT0: PCS Test Error Counter 0 (3×8007)**

Bit	Name	Access	Description	Default
15:0	TSTPAT_ERR_CNT 0	RO	Lower 16 bits of the 32-bit test error counter. This counter is a saturating (non-rollover) counter that is cleared upon a consecutive read to 3×8007 and 3×8008. The contents of this register are identical to 3×002B.	0

**Table 209 • PCS\_ERR\_CNT1: PCS Test Error Counter 1 (3×8008)**

Bit	Name	Access	Description	Default
15:0	TSTPAT_ERR_CNT 1	RO	Upper 16 bits of the 32-bit test error counter. This counter is a saturating (non-rollover) counter that is cleared upon a consecutive read to 3×8007 and 3×8008. <b>Note:</b> When the PCS test counter value reaches 32'hFFFFFFFFD, it will not saturate to 32'hFFFFFFFF, even if the next 64-bit block has three or more bits in error.	0

**Table 210 • Factory Test Register (3×8009)**

Bit	Name	Access	Description	Default
15:0	Reserved	RO	Factory test only; do not modify this bit group	0

**Table 211 • Factory Test Register (3×800C)**

Bit	Name	Access	Description	Default
15:0	Reserved	ROCR	Factory test only; do not modify this bit group	0

**Table 212 • Factory Test Register (3×800D)**

Bit	Name	Access	Description	Default
15:0	Reserved	ROCR	Factory test only; do not modify this bit group	0

**Table 213 • Factory Test Register (3×800E)**

Bit	Name	Access	Description	Default
15:0	Reserved	ROCR	Factory test only; do not modify this bit group	0

**Table 214 • Factory Test Register (3×800F)**

Bit	Name	Access	Description	Default
15:0	Reserved	ROCR	Factory test only; do not modify this bit group	0

**Table 215 • Factory Test Register (3×8010)**

Bit	Name	Access	Description	Default
15:0	Reserved	ROCR	Factory test only; do not modify this bit group	0

**Table 216 • Factory Test Register (3×8011)**

Bit	Name	Access	Description	Default
15:0	Reserved	ROCR	Factory test only; do not modify this bit group	0

**Table 217 • Factory Test Register (3×8012)**

Bit	Name	Access	Description	Default
15:0	Reserved	ROCR	Factory test only; do not modify this bit group	0

**Table 218 • Factory Test Register (3×8013)**

Bit	Name	Access	Description	Default
15:0	Reserved	ROCR	Factory test only; do not modify this bit group	0

**Table 219 • Factory Test Register (3×8014)**

Bit	Name	Access	Description	Default
15:0	Reserved	ROCR	Factory test only; do not modify this bit group	0

**Table 220 • Factory Test Register (3×8015)**

Bit	Name	Access	Description	Default
15:0	Reserved	ROCR	Factory test only; do not modify this bit group	0



**Table 221 • PCS\_CFG2: PCS Configuration 2 (3×E600)**

Bit	Name	Access	Description	Default
15:3	Reserved	RO	Reserved	0
2	PR58_INV_DIS	RW	Disable the periodic inversion of the psuedo-random test pattern for both transmit and receive paths 0: Enable 1: Disable	0
1	FAULT_TX_SE L	RW	Selects error types to trigger a transmit fault 0: FIFO over/underflow condition only 1: Character encoding error, block encoding error, FIFO over/underflow condition <b>Note:</b> For optimal fault indication coverage, set to 1.	0
0	RX_STAT_SEL	RW	Selects contributing logic for receive link status 0: BLOCK_LOCK = 0 1: BLOCK_LOCK = 0 or HIGH_BER = 1 <b>Note:</b> For optimal fault indication coverage, set to 1.	0

**Table 222 • Factory Test Register (3×E601)**

Bit	Name	Access	Description	Default
15:0	Reserved	RO	Factory test only; do not modify this bit group	0

**Table 223 • Factory Test Register (3×E602)**

Bit	Name	Access	Description	Default
15:0	Reserved	RO	Factory test only; do not modify this bit group	0

**Table 224 • Factory Test Register (3×E603)**

Bit	Name	Access	Description	Default
15:0	Reserved	RW	Factory test only; do not modify this bit group	0

**Table 225 • EPCS\_STAT1: E-PCS Status 1 (3×E604)**

Bit	Name	Access	Description	Default
15:8	Reserved	RO	Reserved	0
7:5	LSM_TX_STATE	RO	Current Tx LSM state	0
4	LSM_RX_STAT	RO	Status of Rx framing 0: E-PCS is not framed 1: E-PCS is framed	0

**Table 225 • EPCS\_STAT1: E-PCS Status 1 (3×E604) (continued)**

Bit	Name	Access	Description	Default
3	RX_MSG_RDY	ROCR	Notification that a new HDLC message has been received 0: No change to HDLC frame 1: New HDLC frame received	0
2:0	LSM_RX_STATE	RO	Current Rx LSM state	0

**Table 226 • EPCS\_CORR\_CNT: E-PCS Corrected FEC Error Counter (3×E605)**

Bit	Name	Access	Description	Default
15:0	CORR_ERR_CNT	RO	Count of corrected E-PCS frames over the previous second. Counter is reset every second. Counter is not cumulative and does not roll over. Saturating (non-rollover) counter is cleared by assertion of CLR_CNT. Cleared when 3×E601.1 is set.	0

**Table 227 • EPCS\_UCORR\_CNT: E-PCS Uncorrected FEC Error Counter (3×E606)**

Bit	Name	Access	Description	Default
15:0	UNCORR_ERR_CNT	RO	Count of uncorrected E-PCS frames over the previous second. Counter is reset every second. Counter is not cumulative and does not roll over. Saturating (non-rollover) counter is cleared by assertion of CLR_CNT. Cleared when 3×E601.1 is set.	0

**Table 228 • EPCS\_TXMSG: E-PCS Tx Message (3×E60A-E611)**

Bit	Name	Access	Description	Default
15:0	TX_MSG	RW	128-bit message for in-band transmission to the far end link partner. The 3×E60A is the MSW while 3×E611 is the LSW.	0

**Table 229 • EPCS\_RXMSG: E-PCS Rx Message (3×E612-E619)**

Bit	Name	Access	Description	Default
15:0	RX_MSG	RO	128-bit message received from the far end link partner. Frame delineation is not supported, thus higher level software must determine the MSW.	0

**Table 230 • Factory Test Register (3×E61A)**

Bit	Name	Access	Description	Default
15:3	Reserved	RO	Factory test only; do not modify this bit group	0
2	Reserved	RW	Factory test only; do not modify this bit	0
1	Reserved	RW	Factory test only; do not modify this bit	0
0	Reserved	RW	Factory test only; do not modify this bit	0

**Table 231 • Factory Test Register (3×E61B)**

Bit	Name	Access	Description	Default
15:8	Reserved	RW	Factory test only; do not modify this bit group	0×10
7:0	Reserved	RW	Factory test only; do not modify this bit group	0×14

**Table 232 • Factory Test Register (3×E61C)**

Bit	Name	Access	Description	Default
15:0	Reserved	RO	Factory test only; do not modify this bit group	0

**Table 233 • Factory Test Register (3×E61D)**

Bit	Name	Access	Description	Default
15:5	Reserved	RO	Factory test only; do not modify this bit group	0
4:0	Reserved	RO	Factory test only; do not modify this bit group	0

## 4.4 Device 4: PHY-XS Registers

The following tables provide settings for the registers related to the PHY-XS.

**Table 234 • PHYXS\_CTRL1: PHY XS Control 1 (4×0000)**

Bit	Name	Access	Description	Default
15	SOFT_RST	RWSC	Reset all MMDs 0: Normal operation. 1: Reset	0
14	LPBK_A	RW	Enables PHY XS network loopback (loopback A) 0: Disable 1: Enable Register 4×E600.1 must be set to 1 to enable loopback A.	0
13	SPEED_SEL_A	RO	PHY XS speed capability 0: Unspecified 1: Operates at 10 Gbps or above	1
12	Reserved	RO	Reserved (value always 0, writes ignored)	0

**Table 234 • PHYXS\_CTRL1: PHY XS Control 1 (4×0000) (continued)**

Bit	Name	Access	Description	Default
11	LOW_PWR	RW	PHY XS low power mode control 0: Normal operation 1: Low Power	0
10:7	Reserved	RO	Reserved (value always 0, writes ignored)	0
6	SPEED_SEL_B	RO	PHY XS Speed capability 0: Unspecified 1: Operates at 10 Gbps or above	1
5:2	SPEED_SEL_C	RO	PHY XS speed selection 1xx: Reserved x1x: Reserved xx1x: Reserved 0001: Reserved 0000: 10 Gbps	0
1:0	Reserved	RO	Reserved (value always 0, writes ignored)	0

**Table 235 • PHYXS\_STAT1: PHY XS Status1 (4×0001)**

Bit	Name	Access	Description	Default
15:8	Reserved	RO	Reserved (ignore when read)	0
7	FAULT	RO	PHY XS fault status. Asserted when either the PHY XS FAULT_RX (4×0008.10) or PHY XS FAULT_TX (4×0008.11) is asserted. 0: No faults asserted. 1: Fault asserted.	0
6:3	Reserved	RO	Reserved (ignore when read)	0
2	TX_LNK_STAT	RO/LL	PHY XS transmit link status 0: PHY XS transmit link is down (4×0018.12 = 0) 1: PHY XS transmit link is up (4×0018.12 = 1)	1
1	LOW_PWR_ABILITY	RO	Low power mode support ability 0: Not supported 1: Supported	1
0	Reserved	RO	Reserved (ignore when read)	0

**Table 236 • PHYXS\_DEVID1: PHY XS Device Identifier 1 (4×0002)**

Bit	Name	Access	Description	Default
15:0	DEV_ID_LSW	RO	Upper 16 bits of a 32-bit unique PHY XS device identifier. Bits 3-18 of the device manufacturer's OUI. Device identifier bits 31:16.	0×0007

**Table 237 • PHYXS\_DEVID2: PHY XS Device Identifier 2 (4×0003)**

Bit	Name	Access	Description	Default
15:0	DEV_ID_MSW	RO	Lower 16 bits of a 32-bit unique PHY XS device identifier. Bits 19-24 of the device manufacturer's OUI. Six-bit model number, and a four-bit revision number. Device identifier bits 15:0.	0×0400

**Table 238 • PHYXS\_SPEED: PHY XS Speed Capability (4×0004)**

Bit	Name	Access	Description	Default
15:1	Reserved	RO	Reserved for future speeds (value always 0, writes ignored)	0
0	RATE_ABILITY	RO	PHY XS rate capability 0: Not capable of 10 Gbps 1: Capable of 10 Gbps	1

**Table 239 • PHYXS\_DEVPKG1: PHY XS Devices in Package 1 (4×0005)**

Bit	Name	Access	Description	Default
15:6	Reserved	RO	Reserved (ignore when read).	0
5	DTE_XS_PRES	RO	Indicates whether device includes DTS XS. 0: Not present. 1: Present.	0
4	PHY_XS_PRES	RO	Indicates whether device includes PHY XS. 0: Not present. 1: Present.	1
3	PCS_PRES	RO	Indicates whether PCS is present in the package. 0: Not present. 1: Present.	1
2	WIS_PRES	RO	Indicates whether WIS is present in the package. 0: Not present. 1: Present.	1
1	PMD_PMA_PRES	RO	Indicates whether PMA/PMD is present in the package. 0: Not present. 1: Present.	1
0	CLS22_PRES	RO	Indicates whether Clause 22 registers are present in the package. 0: Not present. 1: Present.	0

**Table 240 • PHYXS\_DEVPKG2: PHY XS Devices in Package 2 (4×0006)**

Bit	Name	Access	Description	Default
15	VS2_PRES	RO	Vendor specific device 2 present 0: Not present 1: Present	0
14	VS1_PRES	RO	Vendor specific device 1 present 0: Not present 1: Present	0
13:0	Reserved	RO	Reserved (ignore when read)	0

**Table 241 • PHYXS\_STAT2: PHY XS Status 2 (4×0008)**

Bit	Name	Access	Description	Default
15:14	DEV_PRES	RO	Reflects the presence of a MMD responding at this address. 10: Device responding at this address. 11: No device responding at this address. 10: No device responding at this address. 00: No device responding at this address.	10
13:12	Reserved	RO	Reserved (ignore when read).	0
11	FAULT_TX	RO/LH	Indicates a fault condition on the transmit path. 0: No fault condition. XGXS lanes are aligned, 4×0018.12 = 1. 1: Fault condition. XGXS lanes are not aligned, 4×0018.12 = 0. Linked to 1E×9004.0. Read to either register clears both bits if fault condition no longer exists.	0
10	FAULT_RX	RO/LH	Indicates a fault condition on the receive path. 0: Rx PCS block is locked to the data and not reporting a high bit error rate. 1: Rx PCS block is not locked to the data or reporting a high bit error rate.	0
9:0	Reserved	RO	Reserved (ignore when read).	0

**Table 242 • PHYXS\_STAT3: PHY XS Status 3 (4×0018)**

Bit	Name	Access	Description	Default
15:13	Reserved	RO	Reserved (ignore when read)	0
12	LANES_ALIGNED	RO	PHY XGXS lane alignment status 0: PHY XS transmit lanes are not aligned 1: PHY XS transmit lanes are aligned	0
11	PATT_ABILITY	RO	PHY XGXS test pattern generation ability 0: PHY XS is not able to generate test patterns 1: PHY XS is able to generate test patterns	1

**Table 242 • PHYXS\_STAT3: PHY XS Status 3 (4×0018) (continued)**

Bit	Name	Access	Description	Default
10	LPBK_ABILITY	RO	PHY XGXS loopback ability 0: PHY XS does not have the ability to perform a loopback function 1: PHY XS has the ability to perform a loopback function	1
9:4	Reserved	RO	Reserved (ignore when read)	0
3	LANE3_SYNC	RO	PHY XGXS lane 3 synchronization status 0: Not synchronized 1: Synchronized	0
2	LANE2_SYNC	RO	PHY XGXS lane 2 synchronization status 0: Not synchronized 1: Synchronized	0
1	LANE1_SYNC	RO	PHY XGXS lane 1 synchronization status 0: Not synchronized 1: Synchronized	0
0	LANE0_SYNC	RO	PHY XGXS lane 0 synchronization status 0: Not synchronized 1: Synchronized	0

**Table 243 • PHYXS\_TSTCTRL1: PHY XGXS Test Control 1 (4×0019)**

Bit	Name	Access	Description	Default
15:3	Reserved	RO	Reserved (value always 0, writes ignored)	0
2	TST_PATT_CHK_EN A	RW	PHYXS test pattern checker enable 0: Disable 1: Enable	0
1:0	TST_PATT_CHK_SE L	RW	PHYXS test pattern checker pattern select 111: 2 <sup>7</sup> PRBS Pattern 110: Fibre Channel CJPAT 101: Continuous jitter test pattern 100: Continuous random test pattern 011: Disable pattern generator 010: Mixed frequency test pattern 001: Low frequency test pattern 000: High frequency test pattern MSB is 4×8000.3. Additionally, two types of CJPAT patterns are provided. For more information, see <a href="#">Table 267</a> , page 179.	0

**Table 244 • PHYXS\_TSTCTRL2: PHY XS Test Control 2 (4×8000)**

Bit	Name	Access	Description	Default
15:5	Reserved	RO	Reserved	0
4	TST_PATT_GEN_EN A	RW	PHYXS test pattern generator enable 0: Disable 1: Enable	0

**Table 244 • PHYXS\_TSTCTRL2: PHY XS Test Control 2 (4×8000) (continued)**

Bit	Name	Access	Description	Default
3	TST_PATT_MODE	RW	Transmit test pattern checker select bit 2 Use with register 4×0019.1:0	0
2:0	TST_PATT_GEN_SEL	RW	PHYXS test pattern generator select 111: 2 <sup>7</sup> PRBS pattern 110: Fibre Channel CJPAT 101: Continuous jitter test pattern 100: Continuous random test pattern 011: Disable pattern generator 010: Mixed frequency test pattern 001: Low frequency test pattern 000: High frequency test pattern Two types of CJPAT patterns are provided. For more information, see <a href="#">Table 267</a> , page 179.	011

**Table 245 • PHYXS\_TSTSTAT: PHY XS Test Pattern Check Status (4×8001)**

Bit	Name	Access	Description	Default
15:4	Reserved	RO	Reserved	0
3	LANE3_PATT_CHK	RO	Lane 3 test pattern check result 0: Pattern check fail 1: Pattern check pass	0
2	LANE2_PATT_CHK	RO	Lane 2 test pattern check result 0: Pattern check fail 1: Pattern check pass	0
1	LANE1_PATT_CHK	RO	Lane 1 test pattern check result 0: Pattern check fail 1: Pattern check pass	0
0	LANE0_PATT_CHK	RO	Lane 0 test pattern check result 0: Pattern check fail 1: Pattern check pass	0

**Table 246 • Factory Test Register (4×8002)**

Bit	Name	Access	Description	Default
15:0	Reserved	RO	Factory test only; do not modify this bit group	0

**Table 247 • Factory Test Register (LSW) (4×8003)**

Bit	Name	Access	Description	Default
15:0	Reserved	RO	Factory test only; do not modify this bit group	0



**Table 248 • Factory Test Register (4×8004)**

Bit	Name	Access	Description	Default
15:0	Reserved	RO	Factory test only; do not modify this bit group	0

**Table 249 • Factory Test Register (4×8005)**

Bit	Name	Access	Description	Default
15:0	Reserved	RO	Factory test only; do not modify this bit group	0

**Table 250 • Factory Test Register (4×8006)**

Bit	Name	Access	Description	Default
15:0	Reserved	RO	Factory test only; do not modify this bit group	0

**Table 251 • Factory Test Register (4×8007)**

Bit	Name	Access	Description	Default
15:0	Reserved	RO	Factory test only; do not modify this bit group	0

**Table 252 • Factory Test Register (4×8008)**

Bit	Name	Access	Description	Default
15:0	Reserved	RO	Factory test only; do not modify this bit group	0

**Table 253 • Factory Test Register (4×8009)**

Bit	Name	Access	Description	Default
15:0	Reserved	RO	Factory test only; do not modify this bit group	0

**Table 254 • Factory Test Register (4×800A)**

Bit	Name	Access	Description	Default
15:0	Reserved	RO	Factory test only; do not modify this bit group	0

**Table 255 • PHYXS\_TPERR\_CTRL: PHY XS Test Pattern Error Counter Control (4×800B)**

Bit	Name	Access	Description	Default
15:5	Reserved	RO	Reserved	0

**Table 255 • PHYXS\_TPERR\_CTRL: PHY XS Test Pattern Error Counter Control (4×800B) (continued)**

Bit	Name	Access	Description	Default
4	TP_CNT_CLR	RWSC	Clear test pattern mismatch error counter 0: Normal operation 1: Clear counter	0
3	TP_CNT_ENA	RW	Test pattern mismatch error counter enable 0: Disable 1: Enable	1
2:0	TP_CNT_SEL	RW	Selects test pattern mismatch error source 111: Reserved 110: Reserved 101: Reserved 100: Cumulative error count on all lanes 011: Error count on lane 3 010: Error count on lane 2 001: Error count on lane 1 000: Error count on lane 0	100

**Table 256 • PHYXS\_TPERR\_CNT0: PHY XS Test Pattern Error Counter 0 (LSW) (4×800C)**

Bit	Name	Access	Description	Default
15:0	TP_CNT_LSW	RO	Test pattern mismatch error counter. Lower 16-bits of the saturating (non-rollover) counter. Saturating counter.	0

**Table 257 • PHYXS\_TPERR\_CNT0: PHY XS Test Pattern Error Counter 1 (MSW) (4×800D)**

Bit	Name	Access	Description	Default
15:0	TP_CNT_MSW	RO	Test pattern mismatch error counter. Upper 16-bits of the saturating (non-rollover) counter. Saturating counter.	0

**Table 258 • PHYXS\_XAUI\_CTRL1: PHY XS XAUI Control 1 (4×800E)**

Bit	Name	Access	Description	Default
15:14	Reserved	RO	Reserved.	0
13	LPBK_B	RW	Loopback B enable (PHY XS shallow system). 0: Disable. 1: Enable. High-speed transmitter outputs transmit data. Use register 1×EF10 to select options to transmit all ones, all zeros, 0×00FF pattern, or XAUI data.	0
12	Reserved	RWSC	Factory test only; do not modify this bit.	1
11	Reserved	RO	Factory test only; do not modify this bit.	1
10	Reserved	RO	Factory test only; do not modify this bit.	0
9	Reserved	RO	Factory test only; do not modify this bit.	0

**Table 258 • PHYXS\_XAUI\_CTRL1: PHY XS XAUI Control 1 (4×800E) (continued)**

Bit	Name	Access	Description	Default
8:5	RX_SQUELCH_XAUI	RW	Force receive XAUI data to zero (bit 8 corresponds to lane 3, and bit 5 corresponds to lane 0). 0: Normal operation. 1: Force data to zero.	0
4	Reserved	RO	Factory test only; do not modify this bit.	0
3	Reserved	RW	Factory test only; do not modify this bit.	0
2	Reserved	RO	Reserved.	0
1	Reserved	RO	Reserved.	0
0	Reserved	RW	Factory test only; do not modify this bit.	0

**Table 259 • PHYXS\_XAUI\_CTRL2: PHY XS XAUI Control 2 (4×800F)**

Bit	Name	Access	Description	Default
15:13	Reserved	RO	Reserved	0
12	Reserved	RW	Factory test only; do not modify this bit	0
11	Reserved	RW	Factory test only; do not modify this bit	0
10	RX_LANE_SWAP	RW	Swaps receive lane 0 with lane 3 and lane 1 with lane 2 0: Enable 1: Disable	1
9	TX_LANE_SWAP	RW	Swaps transmit lane 0 with lane 3 and lane 1 with lane 2 0: Enable 1: Disable	1
8	Reserved	RW	Factory test only; do not modify this bit	0
7	Reserved	RW	Factory test only; do not modify this bit	0
6	RX_INV	RW	Disable XAUI input (receive) data invert 0: Enable 1: Disable	1
5	TX_INV	RW	Disable XAUI output (transmit) data invert 0: Enable 1: Disable	1
4	Reserved	RO	Reserved	0
3	Reserved	RW	Factory test only; do not modify this bit	0
2	LPBK_C	RW	Enables loopback C (XAUI side loopback at XGMII interface) 0: Disable 1: Enable	0
1	LPBK_D	RW	Enables loopback D (XFI side loopback at XGMII interface) 0: Disable 1: Enable	0
0	Reserved	RW	Factory test only; do not modify this bit	0

**Table 260 • PHYXS\_RXEQ\_CTRL: PHY XS XAUI Rx Equalization Control (4×8010)**

Bit	Name	Access	Description	Default
15:12	LANE0_EQ	RW	Equalization setting for XAUI input lane 0 0000: 0 dB 0001: 1.41 dB 0010: 2.24 dB 0011: 2.83 dB 0101: 4.48 dB 0110: 5.39 dB 0111: 6.07 dB 1001: 6.18 dB 1010: 7.08 dB 1011: 7.79 dB 1101: 9.96 dB 1110: 10.84 dB 1111: 11.55 dB	0
11:8	LANE1_EQ	RW	Equalization setting for XAUI input lane 1 Refer to bits [15:12] for settings	0
7:4	LANE2_EQ	RW	Equalization setting for XAUI input lane 2 Refer to bits [15:12] for settings	0
3:0	LANE3_EQ	RW	Equalization setting for XAUI input lane 3 Refer to bits [15:12] for settings	0

**Table 261 • PHYXS\_TXPE\_CTRL: PHY XS XAUI Tx Pre-emphasis Control (4×8011)**

Bit	Name	Access	Description	Default
15	Reserved	RO	Reserved.	0
14:13	LANE0_PE	RW	Pre-emphasis setting for XAUI output lane 0. 00: 0 dB. 01: ~2.5 dB. 10: ~6 dB. 11: ~12 dB.	0
12	Reserved	RO	Reserved.	0
11:10	LANE1_PE	RW	Pre-emphasis setting for XAUI output lane 1. Refer to bits [14:13] for settings.	0
9	Reserved	RO	Reserved.	0
8:7	LANE2_PE	RW	Pre-emphasis setting for XAUI output lane 2. Refer to bits [14:13] for settings.	0
6	Reserved	RO	Reserved.	0
5:4	LANE3_PE	RW	Pre-emphasis setting for XAUI output lane 3. Refer to bits [14:13] for settings.	0
3:2	LOS_THRES	RW	The following estimated settings can be used for various LOS_THRES. 11: 80 mV to 205 mV differential peak-to-peak. 10: 70 mV to 195 mV differential peak-to-peak. 01: 60 mV to 185 mV differential peak-to-peak. 00: 50 mV to 175 mV differential peak-to-peak.	0

**Table 261 • PHYXS\_TXPE\_CTRL: PHY XS XAUI Tx Pre-emphasis Control (4×8011) (continued)**

Bit	Name	Access	Description	Default
1	HS_ENA	RW	Enables XAUI output high swing mode. 0: Disable. 1: Enable. Low swing mode is recommended as there is no significant output amplitude difference between high swing mode and low swing mode.	0
0	Reserved	RO	Reserved.	0

**Table 262 • PHYXS\_RXLOS\_STAT: PHY XS Rx Loss of Signal Status (4×8012)**

Bit	Name	Access	Description	Default
15:7	Reserved	RO	Reserved	0
6	GLBL_SYNC	RO	PHY XS code group synchronization status 0: At least one lane is not in sync 1: All lanes are in sync	0
5	XS_LOL	RO	PHY XS PLL loss of lock 0: PLL in lock 1: PLL loss of lock	0
4	Reserved	RO	Reserved	0
3	LANE3_LOS	RO	Loss of signal status for lane 3 XAUI input <sup>1</sup> 0: Lane 3 signal present 1: Lane 3 loss of signal	0
2	LANE2_LOS	RO	Loss of signal status for lane 2 XAUI input <sup>1</sup> 0: Lane 2 signal present 1: Lane 2 loss of signal	0
1	LANE1_LOS	RO	Loss of signal status for lane 1 XAUI input <sup>1</sup> 0: Lane 1 signal present 1: Lane 1 loss of signal	0
0	LANE0_LOS	RO	Loss of signal status for lane 0 XAUI input <sup>1</sup> 0: Lane 0 signal present 1: Lane 0 loss of signal	0

1. While there is no issue on the actual data path, this real time detection signal can chatter when the amplitude of the input signal is larger than 1200 mV or the equivalent frequency is above 1.6 GHz

**Table 263 • PHYXS\_RXSD\_STAT: PHY XS Rx Signal Detect Status (4×E600)**

Bit	Name	Access	Description	Default
15:2	Reserved	RO	Factory test only; do not modify this bit group	0
1	GLBL_SIG_DET	RW	Disable signal detect function of all XAUI inputs 0: Enabled 1: Disabled When no signal is connected to XAUI bus, set this bit to 1 for proper loopback A function.	0

**Table 263 • PHYXS\_RXSD\_STAT: PHY XS Rx Signal Detect Status (4×E600) (continued)**

Bit	Name	Access	Description	Default
0	SIG_DET	RO	Global signal detect status 0: No signal detected in at least one lane 1: Signal detected in all lanes	N/A

**Table 264 • Factory Test Register (4×E601)**

Bit	Name	Access	Description	Default
15:9	Reserved	RO	Reserved	0
8	Reserved	RW	Factory test only; do not modify this bit	0
7:0	Reserved	RW	Factory test only; do not modify this bit group	0×01

**Table 265 • PHYXS\_TXPD\_CTRL: PHY XS XAUI Tx Power Down Control (4×E602)**

Bit	Name	Access	Description	Default
15	Reserved	RO	Reserved	0
14	LANE3_TX_PD	RW	Power down XAUI lane 3 from the system host into the VSC8486-04 device 0: Powered up 1: Powered down Not changed with lane swap control (4×800F)	0
13	LANE2_TX_PD	RW	Power down XAUI lane 2 from the system host into the VSC8486-04 device 0: Powered up 1: Powered down Not changed with lane swap control (4×800F)	0
12	LANE1_TX_PD	RW	Power down XAUI lane 1 from the system host into the VSC8486-04 device 0: Powered up 1: Powered down Not changed with lane swap control (4×800F)	0
11	LANE0_TX_PD	RW	Power down XAUI lane 0 from the system host into the VSC8486-04 device 0: Powered up 1: Powered down Not changed with lane swap control (4×800F)	0
10:9	LPBK_B_CLK	RW	Selects which of the four recovered clocks will be used for loopback B (PHY XS shallow system loopback) 11: Lane 3 10: Lane 2 01: Lane 1 00: Lane 0	0

**Table 265 • PHYXS\_TXPD\_CTRL: PHY XS XAUI Tx Power Down Control (4xE602) (continued)**

Bit	Name	Access	Description	Default
8	LPBK_B_CLKSEL	RW	Enables automatic clock selection for loopback B and select which of the four recovered XAUI receive lane clocks will be used to retime the transmit data 0: Manual select (see bits 10:9) 1: Auto select	1
7:6	Reserved	RO	Factory test only; do not modify this bit group	0
5:4	Reserved	RO	Factory test only; do not modify this bit group	0
3:2	Reserved	RO	Factory test only; do not modify this bit group	0
1:0	Reserved	RO	Factory test only; do not modify this bit group	0

**Table 266 • PHYXS\_RXPD\_CTRL: PHY XS XAUI Rx Power Down Control (4xE603)**

Bit	Name	Access	Description	Default
15:10	Reserved	RO	Reserved	0
9	Reserved	RW	Factory test only; do not modify this bit	0
8	Reserved	RW	Factory test only; do not modify this bit	1
7	LANE3_RX_PD	RW	Power down XAUI lane 3 from the VSC8486-04 device into the system host 0: Powered up 1: Powered down	0
6	LANE2_RX_PD	RW	Power down XAUI lane 2 from the VSC8486-04 device into the system host 0: Powered up 1: Powered down	0
5	LANE1_RX_PD	RW	Power down XAUI lane 1 from the VSC8486-04 device into the system host 0: Powered up 1: Powered down	0
4	LANE0_RX_PD	RW	Power down XAUI lane 0 from the VSC8486-04 device into the system host 0: Powered up 1: Powered down	0
3	LANE3_RX_SQU	RW	Force to zero PHY XS Rx lane 3 high-speed data that is output from the VSC8486-04 device 0: Output normal 1: Output squelched	0
2	LANE2_RX_SQU	RW	Force to zero PHY XS Rx lane 2 high-speed data that is output from the VSC8486-04 device 0: Output normal 1: Output squelched	0
1	LANE1_RX_SQU	RW	Force to zero PHY XS Rx lane 1 high-speed data that is output from the VSC8486-04 device 0: Output normal 1: Output squelched	0

**Table 266 • PHYXS\_RXPD\_CTRL: PHY XS XAUI Rx Power Down Control (4×E603) (continued)**

Bit	Name	Access	Description	Default
0	LANE0_RX_SQU	RW	Force to zero PHY XS Rx lane 0 high-speed data that is output from the VSC8486-04 device 0: Output normal 1: Output squelched	0

**Table 267 • FC\_CJPAT\_SEL (4×E604)**

Bit	Name	Access	Description	Default
15:2	Reserved	RW	Reserved	0
1	FC_CJPAT_CHK_MOD3 1	RW	0: Revision 3.5 compliant CJPAT checker. 1: Revision 3.1 compliant CJPAT checker.	1
0	FC_CJPAT_GEN_MOD3 1	RW	0: Revision 3.5 compliant CJPAT generator. 1: Revision 3.1 compliant CJPAT generator.	1

**Table 268 • Factory Test Register (4×E610)**

Bit	Name	Access	Description	Default
15:4	Reserved	RO	Reserved	0
3:0	Reserved	RW	Factory test only; do not modify this bit group	0

## 4.5 Device 30: NVR and DOM Registers

The following tables provide settings for the registers related to the NVR and DOM.

**Table 269 • STW\_CTRL1: STW Control 1 (1E×8000)**

Bit	Name	Access	Description	Default
15:13	Reserved	RO	Reserved	0
12:9	Reserved	RW	Reserved	0
8	STW_MODE	RW	Two-wire serial operating mode control. Must be set to 0. Do not write 1 to this bit. 0: Automatic mode	0
7:6	Reserved	RO	Reserved	0
5	STW_CMD	RW	Command type for automatic mode 0: Read 1: Write	0
4	Reserved	RO	Reserved	0



**Table 269 • STW\_CTRL1: STW Control 1 (1E×8000) (continued)**

Bit	Name	Access	Description	Default
3:2	STW_CMD_STATU S	RO	Command status (these bits clear on read, but if a condition persists, the bits maintain their value) 00: Idle 01: Command completed successfully 10: Command in progress 11: Command failed <b>Note:</b> If this register becomes stuck in command-in-progress state (10), it must be restored to idle state by issuing a software reset command through register 1×EF01.15.	0
1:0	STW_EXT_CMD	RW	Extended command; the range of addressing is influenced by STW_MSA_TYPE 00: XENPAK (11-118), XFP (2-57) 01: XENPAK (119-166), XFP (72-111) 10: XENPAK (167-255), XFP (0-127) 11: XENPAK (0-255), XFP (128-255)	0

**Table 270 • STW\_DEVADDR: STW Device Address (1E×8002)**

Bit	Name	Access	Description	Default
15:7	Reserved	RW	Reserved	0
6:3	STW_DEV_TYP E	RW	Target two-wire serial slave device type	0
2:0	STW_ADDR	RW	Target two-wire serial slave device address	0

**Table 271 • STW\_REGADDR: STW Register Address (1E×8003)**

Bit	Name	Access	Description	Default
15:0	STW_REG	RW	Intended register address to access within the two-wire serial slave device	0

**Table 272 • STW\_CFG1: STW Configuration 1 (1E×8004)**

Bit	Name	Access	Description	Default
15:13	Reserved	RW	Reserved	0
12	STW_MSA_MODE	RW	MSA register map compliance type; this influences the STW_EXT_CMD selection. 0: XENPAK 1: XFP	0

**Table 272 • STW\_CFG1: STW Configuration 1 (1E×8004) (continued)**

Bit	Name	Access	Description	Default
11	STW_ADDR_MODE	RW	Selects the two-wire serial device addressing mode 0: 7-bit 1: Reserved	0
10:9	STW_SPEED_MODE	RW	Selects the two-wire serial bus speed 00: Standard (100 kHz) 01: Fast (400 kHz) 1x: Reserved	0
8:0	Reserved	RW	Reserved	0

**Table 273 • NVR Memory Map (1E×8007-8106)**

Bit	Name	Access	Description	Default
15:8	Reserved	RO	Reserved	0
7:0		RW	Consult the XENPAK or XFP specifications for a description of the NVR mapping.	0

**Table 274 • DOM\_RXALRM\_CTRL: DOM Rx Alarm Control (1E×9000)**

Bit	Name	Access	Description	Default
15:5	Reserved	RO	Reserved	0
4	FAULT_RX_PMA_ENA	RW	PMA receive local fault enable 0: Disable 1: Enable	1
3	FAULT_RX_PCS_ENA	RW	PCS receive local fault enable 0: Disable 1: Enable	1
2	VEND_SPEC	RO	Vendor Specific	0
1	FLAG_RX_ENA	RW	RX_FLAG enable 0: Disable 1: Enable	0
0	FAULT_RX_PHYXS_ENA	RW	PHY XS receive local fault enable 0: Disable 1: Enable	1

**Table 275 • DOM\_TXALRM\_CTRL: DOM Tx Alarm Control (1E×9001)**

Bit	Name	Access	Description	Default
15:5	Reserved	RO	Reserved	0
4	FAULT_TX_PMA_ENA	RW	PMA transmit local fault enable 0: Disable 1: Enable	1

**Table 275 • DOM\_TXALRM\_CTRL: DOM Tx Alarm Control (1E×9001) (continued)**

Bit	Name	Access	Description	Default
3	FAULT_TX_PCS_ENA	RW	PCS transmit local fault enable 0: Disable 1: Enable	1
2	VEND_SPEC	RO	Vendor specific	0
1	FLAG_TX_ENA	RW	TX_FLAG enable 0: Disable 1: Enable	0
0	FAULT_TX_PHYXS_ENA	RW	PHY XS transmit local fault enable 0: Disable 1: Enable	1

**Table 276 • DOM\_LASI\_CTRL: DOM Link Alarm Status Interrupt Control (1E×9002)**

Bit	Name	Access	Description	Default
15:3	Reserved	RO	Reserved	0
2	ALARM_RX_ENA	RW	Receive alarm enable 0: Disable 1: Enable	0
1	ALARM_TX_ENA	RW	Transmit alarm enable 0: Disable 1: Enable	0
0	ALARM_LS_ENA	RW	Link status alarm enable 0: Disable 1: Enable	0

**Table 277 • DOM\_RXALRM\_STAT: DOM Rx Alarm Status (1E×9003)**

Bit	Name	Access	Description	Default
15:5	Reserved	RO	Reserved	0
4	FAULT_RX_PMA_STAT	RO/LH	PMA receiver local fault 0: No fault asserted 1: Fault asserted See also 1×0008.10	0
3	FAULT_RX_PCS_STAT	RO/LH	PCS receive local fault 0: No fault asserted 1: Fault asserted See also 3×0008.10	0
2	Vendor Specific	RO	Vendor specific	0
1	FLAG_RX_STAT	RO/LH	Receive flag status 0: No fault asserted 1: Fault asserted	0
0	FAULT_RX_PHYXS_STAT	RO/LH	PHY XS receive local fault 0: No fault asserted 1: Fault asserted See also 4×0008.10	0

**Table 278 • DOM\_TXALRM\_STAT: DOM Tx Alarm Status (1E×9004)**

Bit	Name	Access	Description	Default
15:5	Reserved	RO	Reserved	0
4	FAULT_TX_PMA_STAT	RO/LH	PMA transmit local fault status 0: No fault asserted 1: Fault asserted See also 1×0008.11	0
3	FAULT_TX_PCS_STAT	RO/LH	PCS transmit local fault status 0: No fault asserted 1: Fault asserted See also 3×0008.11	0
2	Vendor Specific	RO	Vendor specific	0
1	FLAG_TX_STAT	RO/LH	Transmit flag fault status 0: No fault asserted 1: Fault asserted	0
0	FAULT_TX_PHYXS_STAT	RO/LH	PHY XS transmit local fault status 0: No fault asserted 1: Fault asserted See also 4×0008.11	0

**Table 279 • DOM\_LASI\_STAT: DOM Link Alarm Status Interrupt Status (1E×9005)**

Bit	Name	Access	Description	Default
15:3	Reserved	RO	Reserved	0
2	ALARM_RX_STAT	RO	Receive alarm status 0: No fault asserted 1: Fault asserted	0
1	ALARM_TX_STAT	RO	Transmit alarm status 0: No fault asserted 1: Fault asserted	0
0	ALARM_LS_STAT	RO/LH	Link status alarm status 0: No status change 1: Status change	0

**Table 280 • DOM\_TXFLAG\_CTRL: DOM Tx Flag Control (1E×9006)**

Bit	Name	Access	Description	Default
15:8	Reserved	RW	Reserved	0
7	TXFLAG_HI_TEMP_ENA	RW	High temperature alarm enable 0: Disable 1: Enable	0
6	TXFLAG_LO_TEMP_ENA	RW	Low temperature alarm enable 0: Disable 1: Enable	0
5:4	Reserved	RW	Reserved	0

**Table 280 • DOM\_TXFLAG\_CTRL: DOM Tx Flag Control (1E×9006) (continued)**

Bit	Name	Access	Description	Default
3	TXFLAG_HI_LBIAS_ENA	RW	Laser bias current high alarm enable 0: Disable 1: Enable	0
2	TXFLAG_LO_LBIAS_ENA	RW	Laser bias current low alarm enable 0: Disable 1: Enable	0
1	TXFLAG_HI_TXPWR_EN A	RW	Laser output power high alarm enable 0: Disable 1: Enable	0
0	TXFLAG_LO_TXPWR_EN A	RW	Laser output power low alarm enable 0: Disable 1: Enable	0

**Table 281 • DOM\_RXFLAG\_CTRL: DOM Rx Flag Control (1E×9007)**

Bit	Name	Access	Description	Default
15:8	Reserved	RW	Reserved	0
7	RXFLAG_HI_RXPWR_EN A	RW	Receive optical power high alarm enable 0: Disable 1: Enable	0
6	RXFLAG_LO_RXPWR_EN A	RW	Receive optical power low alarm enable 0: Disable 1: Enable	0
5:0	Reserved	RW	Reserved	0

**Table 282 • Factory Test Register (1E×A000-A027)**

Bit	Name	Access	Description	Default
15:0	Reserved	RO	Factory test only; do not modify this bit group	0

**Table 283 • Factory Test Register (1E×A048-A05F)**

Bit	Name	Access	Description	Default
15:0	Reserved	RO	Factory test only; do not modify this bit group	0

**Table 284 • Factory Test Register (1E×A060-A06D)**

Bit	Name	Access	Description	Default
15:0	Reserved	RO	Factory test only; do not modify this bit group	0

**Table 285 • Factory Test Register (1E×A06E)**

Bit	Name	Access	Description	Default
15:0	Reserved	RO	Factory test only; do not modify this bit group	0

**Table 286 • Factory Test Register (1E×A06F)**

Bit	Name	Access	Description	Default
15:0	Reserved	RO	Factory test only; do not modify this bit group	0

**Table 287 • DOM\_TXALARM: DOM Tx Alarm Flags (1E×A070)**

Bit	Name	Access	Description	Default
15:8	Reserved	RO	Reserved	0
7	ALARM_HI_XCVRTEMP_STAT	RO	Transceiver temperature high alarm status 0: No alarm asserted 1: Alarm asserted	0
6	ALARM_LO_XCVRTEMP_STAT	RO	Transceiver temperature low alarm status 0: No alarm asserted 1: Alarm asserted	0
5:4	Reserved	RO	Reserved	0
3	ALARM_HI_LBIAS_STAT	RO	Laser bias current high alarm status 0: No alarm asserted 1: Alarm asserted	0
2	ALARM_LO_LBIAS_STAT	RO	Laser bias current low alarm status 0: No alarm asserted 1: Alarm asserted	0
1	ALARM_HI_TXPWR_STAT	RO	Laser output power high alarm status 0: No alarm asserted 1: Alarm asserted	0
0	ALARM_LO_TXPWR_STAT	RO	Laser output power low alarm status 0: No alarm asserted 1: Alarm asserted	0

**Table 288 • DOM\_RXALARM: DOM Rx Alarm Flags (1E×A071)**

Bit	Name	Access	Description	Default
15:8	Reserved	RO	Reserved	0
7	ALARM_HI_RXPWR_STAT	RO	Receive optical power high alarm status 0: No alarm asserted 1: Alarm asserted	0

**Table 288 • DOM\_RXALARM: DOM Rx Alarm Flags (1ExA071) (continued)**

Bit	Name	Access	Description	Default
6	ALARM_LO_RXPWR_STA T	RO	Receive optical power low alarm status 0: No alarm asserted 1: Alarm asserted	0
5:0	Reserved	RO	Reserved	0

**Table 289 • Factory Test Register (1ExA072-A073)**

Bit	Name	Access	Description	Default
15:0	Reserved	RO	Factory test only; do not modify this bit group	0

**Table 290 • DOM\_TXWARN: DOM Tx Warning Flags (1ExA074)**

Bit	Name	Access	Description	Default
15:8	Reserved	RO	Reserved	0
7	WARN_HI_XCVRTEMP_STA T	RO	Transceiver temperature high warning status 0: No warning asserted 1: Warning asserted	0
6	WARN_LO_XCVRTEMP_STA AT	RO	Transceiver temperature low warning status 0: No warning asserted 1: Warning asserted	0
5:4	Reserved	RO	Reserved	0
3	WARN_HI_LBIAS_STAT	RO	Laser bias current high warning status 0: No warning asserted 1: Warning asserted	0
2	WARN_LO_LBIAS_STAT	RO	Laser bias current low warning status 0: No warning asserted 1: Warning asserted	0
1	WARN_HI_TXPWR_STAT	RO	Laser output power high warning status 0: No warning asserted 1: Warning asserted	0
0	WARN_LO_TXPWR_STAT	RO	Laser output power low warning status 0: No warning asserted 1: Warning asserted	0

**Table 291 • DOM\_RXWARN: DOM Rx Warning Flags (1ExA075)**

Bit	Name	Access	Description	Default
15:8	Reserved	RO	Reserved	0

**Table 291 • DOM\_RXWARN: DOM Rx Warning Flags (1ExA075) (continued)**

Bit	Name	Access	Description	Default
7	WARN_HI_RXPWR_STA T	RO	Receive optical power high warning status 0: No warning asserted 1: Warning asserted	0
6	WARN_LO_RXPWR_STA T	RO	Receive optical power low warning status 0: No warning asserted 1: Warning asserted	0
5:0	Reserved	RO	Reserved	0

**Table 292 • Factory Test Register (1ExA076-A077)**

Bit	Name	Access	Description	Default
15:0	Reserved	RO	Factory test only; do not modify this bit group	0

**Table 293 • Factory Test Register (1ExA0C0-A0FF)**

Bit	Name	Access	Description	Default
15:0	Reserved	RO	Factory test only; do not modify this bit group	0

**Table 294 • Factory Test Register (1ExA100)**

Bit	Name	Access	Description	Default
15:0	Reserved	RW	Reserved	0

**Table 295 • Factory Test Register (1ExA101-A106)**

Bit	Name	Access	Description	Default
7:0	Reserved	RW	Factory test only; do not modify this bit group	0



## 5 Electrical Specifications

This section provides the DC characteristics, AC characteristics, recommended operating conditions, and stress ratings for the VSC8486-04 device.

### 5.1 DC Characteristics

This section contains the DC specifications for the VSC8486-04 device.

#### 5.1.1 LVTTTL Inputs and Outputs

The following table shows the LVTTTL I/O specifications for the VSC8486-04 device.

**Table 296 • LVTTTL I/O Specifications**

Parameter	Symbol	Minimum	Maximum	Unit	Condition
Output high voltage	$V_{OH}$	2.4	$V_{DDTTL}$	V	$V_{DDTTL} = 3.3\text{ V}$ and $I_{OH} = -4\text{ mA}$
		1.8	$V_{DDTTL}$		$V_{DDTTL} = 2.5\text{ V}$ and $I_{OH} = -4\text{ mA}$
		1.4	$V_{DDTTL}$		$V_{DDTTL} = 1.8\text{ V}$ and $I_{OH} = -2\text{ mA}$
		1.1	$V_{DDTTL}$		$V_{DDTTL} = 1.5\text{ V}$ and $I_{OH} = -2\text{ mA}$
		0.88	$V_{DDTTL}$		$V_{DDTTL} = 1.2\text{ V}$ and $I_{OH} = -1\text{ mA}$
Output high voltage, open drain	$V_{OH\_OD}$	3.2	$V_{DDTTL}$	V	$V_{DDTTL} = 3.3\text{ V}$ and $I_{OH} = 100\text{ }\mu\text{A}$
		2.4	$V_{DDTTL}$		$V_{DDTTL} = 2.5\text{ V}$ and $I_{OH} = 100\text{ }\mu\text{A}$
		1.7	$V_{DDTTL}$		$V_{DDTTL} = 1.8\text{ V}$ and $I_{OH} = 100\text{ }\mu\text{A}$
		1.4	$V_{DDTTL}$		$V_{DDTTL} = 1.5\text{ V}$ and $I_{OH} = 100\text{ }\mu\text{A}$
		0.9	$V_{DDTTL}$		$V_{DDTTL} = 1.2\text{ V}$ and $I_{OH} = 100\text{ }\mu\text{A}$
Output low voltage (LVTTTL, open drain)	$V_{OL}$	0.0	0.5	V	$V_{DDTTL} = 3.3\text{ V}$ and $I_{OL} = 4\text{ mA}$
		0.0	0.5		$V_{DDTTL} = 2.5\text{ V}$ and $I_{OL} = 4\text{ mA}$
		0.0	0.4		$V_{DDTTL} = 1.8\text{ V}$ and $I_{OL} = 2\text{ mA}$
		0.0	0.2		$V_{DDTTL} = 1.5\text{ V}$ and $I_{OL} = 2\text{ mA}$
		0.0	0.2		$V_{DDTTL} = 1.2\text{ V}$ and $I_{OL} = 1\text{ mA}$
Input high voltage	$V_{IH}$	2.0	$V_{DDTTL}$	V	$V_{DDTTL} = 3.3\text{ V}$
		1.7	$V_{DDTTL}$		$V_{DDTTL} = 2.5\text{ V}$
		1.2	$V_{DDTTL}$		$V_{DDTTL} = 1.8\text{ V}$
		1.05	$V_{DDTTL}$		$V_{DDTTL} = 1.5\text{ V}$
		0.85	$V_{DDTTL}$		$V_{DDTTL} = 1.2\text{ V}$
Input low voltage	$V_{IL}$	0.0	0.8	V	$V_{DDTTL} = 3.3\text{ V}$
		0.0	0.8		$V_{DDTTL} = 2.5\text{ V}$
		0.0	0.6		$V_{DDTTL} = 1.8\text{ V}$
		0.0	0.45		$V_{DDTTL} = 1.5\text{ V}$
		0.0	0.4		$V_{DDTTL} = 1.2\text{ V}$
Input high current	$I_{IH}$		500	$\mu\text{A}$	$V_{IH} = V_{DDTTL}$
Input low current	$I_{IL}$	-50		$\mu\text{A}$	$V_{IL} = 0\text{ V}$

#### 5.1.2 Reference Clock

REFCLKP/N has an exposed center tap (REFTERM), whereas WREFCLKP/N and VREFCLKP/N do not. For more information about reference clock inputs, see [Reference Clock Inputs](#), page 22.

The following table shows the reference clock input specifications for the VSC8486-04 device.

**Table 297 • Reference Clock Input Specifications**

Parameter	Symbol	Minimum	Typical	Maximum	Unit	Condition
Input voltage	$\Delta V_{\text{REFCLK}}$	150		2000	mV	Measured peak-to-peak both sides driven
		300		2000	mV	Measured peak-to-peak single-ended driven
Input common-mode voltage	$V_{\text{CM}}$	700		950	mV	
REFTERM voltage	$V_{\text{REFTERM}}$		$0.67 \times V_{\text{DD12TX}}$		V	$V_{\text{DD12TX}} = 1.2 \text{ V}$

### 5.1.3 MDIO Interface

The following table shows the MDIO interface specifications for the VSC8486-04 device.

**Table 298 • MDIO Interface Characteristics**

Parameter	Symbol	Minimum	Maximum	Unit	Condition
Input high voltage <sup>1</sup>	$V_{\text{IH}}$	0.84	$V_{\text{DDTTL}}$	V	
Input low voltage	$V_{\text{IL}}$	0	0.36	V	
Output high voltage <sup>2</sup>	$V_{\text{OH}}$	1.0	$V_{\text{DDTTL}}$	V	$I_{\text{OH}} = -100 \mu\text{A}$
Output low voltage	$V_{\text{OL}}$	0	0.2	V	$I_{\text{OL}} = 100 \mu\text{A}$
Output high current	$I_{\text{OH}}$		-4	mA	$V_{\text{I}} = 1.5 \text{ V}$
Output low current	$I_{\text{OL}}$	4.0		mA	$V_{\text{I}} = 0.2 \text{ V}$
Input capacitance	$C_{\text{IN}}$		10	pF	
Bus loading	$C_{\text{L}}$		470	pF	

1. Input is 3.3 V tolerant.

2. Output is open drain and pulled up to 1.5 V through a 4.7 k $\Omega$  resistor.

## 5.2 AC Characteristics

This section contains the AC specifications for the VSC8486-04 device.

### 5.2.1 10-Gigabit Inputs and Outputs

The following table shows the serial data input specifications for the VSC8486-04 device. The specifications refer to points A and D in the XFI specification, unless specified otherwise.

**Table 299 • 10-Gigabit Serial Data Input Specifications**

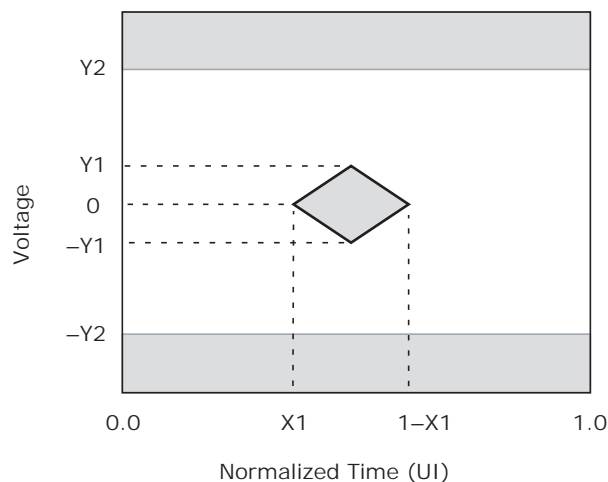
Parameter	Symbol	Minimum	Typical	Maximum	Unit	Condition
Data differential input swing	$\Delta V_{\text{SWING\_DIFF}}$	55		1050	mV	Measured peak-to-peak both sides driven with no offset applied

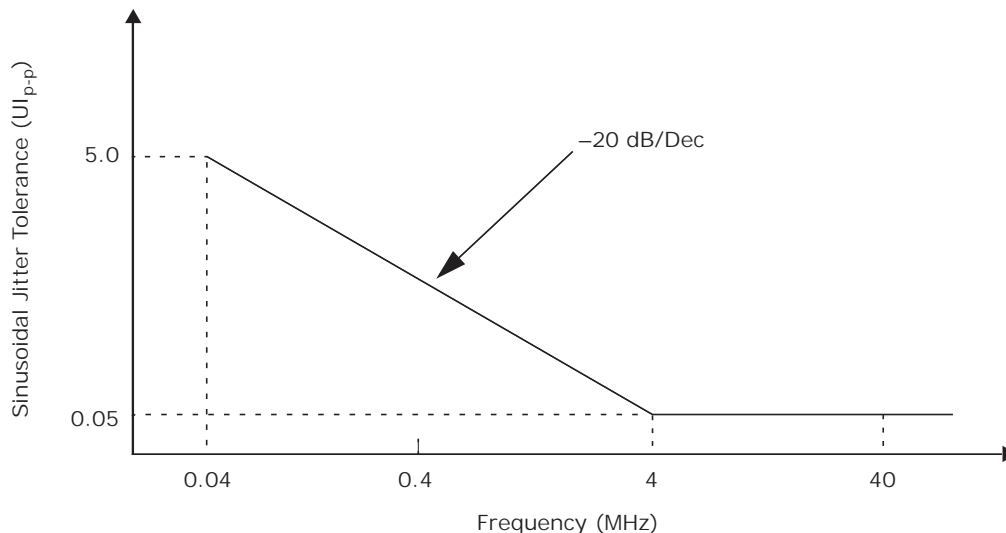
**Table 299 • 10-Gigabit Serial Data Input Specifications (continued)**

Parameter	Symbol	Minimum	Typical	Maximum	Unit	Condition
Data single-ended input swing	$\Delta V_{\text{SWING\_SE}}$	110		1050	mV	Measured peak-to-peak single-ended driven with no offset applied
Differential input impedance <sup>1</sup>	$RZ_{\text{DE\_TERM}}$		98		$\Omega$	RXIN+ to RXIN-
Differential input return loss <sup>1</sup>	SDD11		12		dB	0.1 GHz to 2 GHz 2 GHz to 11.1 GHz
Reflected differential to common mode conversion <sup>1</sup>	SCD11		10		dB	0.1 GHz to 11.1 GHz
Termination resistor current	$I_{\text{TERM}}$			25	mA	RXIN to RXINCM
RXDATA input common-mode voltage	$V_{\text{RXINCM}}$		$0.68 \times V_{\text{DD12RX}}$		V	

1. Limited sample size tested under nominal conditions.

2. Return loss is  $\text{SDD11}(\text{dB}) < -6.68 + 12.1 \times \log_{10}(f/5.5 \text{ GHz})$ , with  $f$  in GHz.

**Figure 61 • 10-Gigabit Data Input Compliance Mask**

**Figure 62 • Datacom Sinusoidal Jitter Tolerance**

The following table shows the CRU input specifications for the VSC8486-04 device.

**Table 300 • 10-Gigabit Data Input Specifications for CRU**

Parameter	Symbol	Minimum	Maximum	Unit	Condition
Difference between REFCLK frequency (with appropriate multiplier) and 10-gigabit input data frequency	$\Delta f_{\text{REFCLK}}$	-100	100	ppm	
Total jitter tolerance	TOL <sub>JIT_P-P</sub>		0.70	UI	Calibrated and measured at point C", as specified in SFF-8431 revision 4.1 using the following EQ and CRU BW settings: 1×8002.14:11 = 1101 1×E604.15 = 1 1×8000.15:14 = 00 Board channel loss is 3 dB.
99% jitter	99%J <sub>JIT_P-P</sub>		0.42	UI	Calibrated and measured at point C", as specified in SFF-8431 revision 4.1 using the following EQ, gain, and CRU BW settings: 1×8002.14:11 = 1110 1×E604.15 = 1 1×8000.15:14 = 00 Board channel loss is 3 dB.

**Table 300 • 10-Gigabit Data Input Specifications for CRU (continued)**

Parameter	Symbol	Minimum	Maximum	Unit	Condition
Pulse width shrinkage jitter	DDPWS <sub>JIT_p-p</sub>		0.3	UI	Calibrated and measured at point C", as specified in SFF-8431 revision 4.1 using the following EQ, gain, and CRU BW settings: 1×8002.14:11 = 1110 1×E604.15 = 1 1×8000.15:14 = 00 Board channel loss is 3 dB.
Sinusoidal jitter, Datacom	S <sub>J_DAT</sub>		See <a href="#">Figure 62</a> , page 191		SFF-8431 specification revision 4.1 Datacom mask.
Eye mask (X1)	X1		0.35	UI	Calibrated and measured at point C", as specified in SFF-8431 revision 4.1 using the following EQ, gain, and CRU BW settings: 1×8002.14:11 = 1110 1×E604.15 = 1 1×8000.15:14 = 00 Board channel loss is 3 dB. See <a href="#">Figure 61</a> , page 190.
Eye mask (Y1)	Y1	150		mV	Calibrated and measured at point C", as specified in SFF-8431 revision 4.1 using the following EQ, gain, and CRU BW settings: 1×8002.14:11 = 1110 1×E604.15 = 1 1×8000.15:14 = 00 Board channel loss is 3 dB. See <a href="#">Figure 61</a> , page 190.
Eye mask (Y2)	Y2		425	mV	Calibrated and measured at point C", as specified in SFF-8431 revision 4.1 using the following EQ, gain, and CRU BW settings: 1×8002.14:11 = 1110 1×E604.15 = 1 1×8000.15:14 = 00 Board channel loss is 3 dB. See <a href="#">Figure 61</a> , page 190.

The following table shows the MUX output specifications for the VSC8486-04 device.

**Table 301 • 10-Gigabit Data Output Specifications for MUX**

Parameter	Symbol	Minimum	Typical	Maximum	Unit	Condition
TXDOUTP/N single-ended output swing at far end	$V_{SE\_FE}$	95		350	mV	Calibrated and measured at point B, as specified in SFF-8431 revision 4.1 using the following PE and DE/swing settings: 1×E601.7:0 = 0x8b 1×E603 = 0x00 Board channel loss is 3 dB.
Common-mode output voltage TXDOUTP/N <sup>1</sup>	$V_{CM}$		0.9		V	
Common-mode return loss <sup>1</sup>	SCC22		See <sup>2</sup>		dB	0.01 GHz to 2.5 GHz.
			3		dB	2.5 GHz to 11.1 GHz.
Differential output return loss <sup>1</sup>	SDD22		-12		dB	0.01 GHz to 2 GHz.
			See <sup>3</sup>		dB	2 GHz to 11.1 GHz.

- Limited sample size tested under nominal conditions.
- Return loss is  $SCC22(dB) < -7 + 1.6 \times f$ , with  $f$  in GHz.
- Return loss is  $SDD22(dB) < -6.68 + 12.1 \times \log_{10}(f/5.5 \text{ GHz})$ , with  $f$  in GHz.

The following table shows the CMU output specifications in WAN mode for the VSC8486-04 device.

**Table 302 • 10-Gigabit Data Output Specifications for CMU, WAN Mode**

Parameter	Symbol	Minimum	Typical	Unit	Condition
TXDOUTP/N jitter	$J_{G\_OUT}$		0.06	UI	Measured peak-to-peak. WREFCLK = 622.08 MHz low jitter. Reference clock required. <sup>1</sup>
RXDINP/N jitter tolerance	$J_{TOL}$	1.5 × SONET jitter mask			Measured peak-to-peak using the following settings: 1×8002.12:11 = 0x2 1×8002.14:13 = 0x3 1×E604.15 = 0x1 1×8000.15:14 = 0x0 Compliant with 1.5 × SONET jitter mask. GR1377-CORE. <sup>2</sup>

- For optimal  $J_G$  and rise and fall time performance, adjustments might be required to the transmit pre-emphasis or transmit slew rate or both in register 1×E601.
- Measured 1 dB above minimum RXIN input sensitivity.

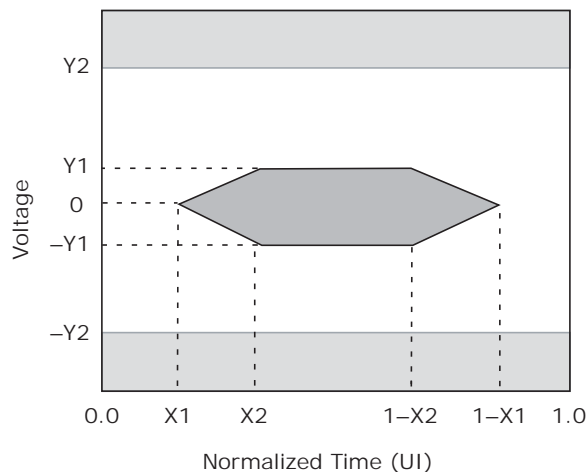
The following table shows the CMU output specifications for the VSC8486-04 device.

**Table 303 • 10-Gigabit Data Output Specifications for CMU, LAN/SAN Mode**

Parameter	Symbol	Minimum	Maximum	Unit	Condition
TXDOUTP/N total jitter	TJDOUT		0.28	UI	Calibrated and measured at point B, as specified in SFF-8431 revision 4.1 using the following PE and DE/swing settings: 1×E601.7:0 = 0x8b 1×E603 = 0x00 Board channel loss is 3 dB.
Data-dependant jitter	DDJ		0.1	UI	Calibrated and measured at point B, as specified in SFF-8431 revision 4.1 using the following PE and DE/swing settings: 1×E601.7:0 = 0x8b 1×E603 = 0x00 Board channel loss is 3 dB.
Data-dependant pulse width shrinkage	DDPWS <sub>p-p</sub>		0.055	UI	Calibrated and measured at point B, as specified in SFF-8431 revision 4.1 using the following PE and DE/swing settings: 1×E601.7:0 = 0x8b 1×E603 = 0x00 Board channel loss is 3 dB.
Uncorrelated jitter	UJ <sub>rms</sub>		0.023	UI	Calibrated and measured at point B, as specified in SFF-8431 revision 4.1 using the following PE and DE/swing settings: 1×E601.7:0 = 0x8b 1×E603 = 0x00 Board channel loss is 3 dB.
CLK64P/N jitter generation	JG <sub>C64</sub>		0.11	UI	Measured peak-to-peak. CLK64A and CLK64B in CMU/64, CMU/66, and CRU/64 modes.
CLK64P/N output swing	ΔV	320	800	mV	Measured peak-to-peak. CLK64A and CLK64B in CMU/64, CMU/66, and CRU/64 modes.
Eye mask (X1)	X1		0.12	UI	Calibrated and measured at point B, as specified in SFF-8431 revision 4.1 using the following PE and DE/swing settings: 1×E601.7:0 = 0x8b 1×E603 = 0x00 Board channel loss is 3 dB. See <a href="#">Figure 63</a> , page 195.

**Table 303 • 10-Gigabit Data Output Specifications for CMU, LAN/SAN Mode (continued)**

Parameter	Symbol	Minimum	Maximum	Unit	Condition
Eye mask (X2)	X2		0.33	UI	Calibrated and measured at point B, as specified in SFF-8431 revision 4.1 using the following PE and DE/swing settings: 1×E601.7:0 = 0x8b 1×E603 = 0x00 Board channel loss is 3 dB. See <a href="#">Figure 63</a> , page 195.
Eye mask (Y1)	Y1	95		mV	Calibrated and measured at point B, as specified in SFF-8431 revision 4.1 using the following PE and DE/swing settings: 1×E601.7:0 = 0x8b 1×E603 = 0x00 Board channel loss is 3 dB. See <a href="#">Figure 63</a> , page 195.
Eye mask (Y2)	Y2		350	mV	Calibrated and measured at point B, as specified in SFF-8431 revision 4.1 using the following PE and DE/swing settings: 1×E601.7:0 = 0x8b 1×E603 = 0x00 Board channel loss is 3 dB. See <a href="#">Figure 63</a> , page 195.

**Figure 63 • 10-Gigabit Data Output Compliance Mask**



## 5.2.2 XAUI Inputs and Outputs

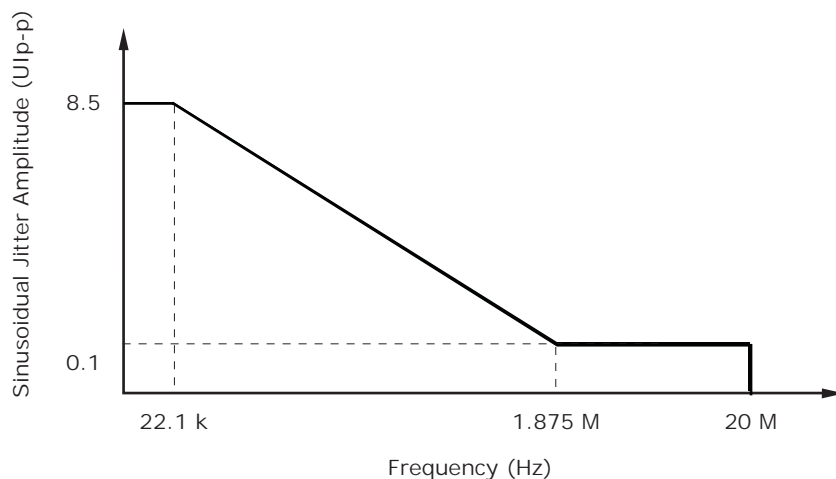
The following shows the XAUI input specifications for the VSC8486-04 device.

**Table 304 • XAUI Input Specifications**

Parameter	Symbol	Minimum	Typical	Maximum	Unit	Condition
Input baud rate	$f$	3.125 – 100 ppm		3.1875 + 100 ppm	Gbps	
Unit interval	UI		320		ps	3.125 Gbps – 100 ppm to 3.1875 Gbps + 100 ppm
Differential input amplitude	$V_{IN\_DIFF}$	75		1600	mV	AC-coupled, measured peak-to-peak each side (both sides driven)
Common-mode input voltage	$V_{IN\_CM}$	0.75		$V_{DDA12} - 0.05$	V	Midpoints between high and low voltages, measured at DC
Differential return loss <sup>1</sup>	$RL_{DIFF}$		10		dB	100 $\Omega$ differential reference impedance
Common-mode return loss <sup>1</sup>	$RL_{CM}$		6		dB	100 MHz to 2.5 GHz, 25 $\Omega$ reference impedance
Differential skew	$SK_{DIFF}$			75	ps	Between true and complement inputs
Jitter tolerance, total	$TOL_{TJ}$	0.65			UI	Measured peak-to-peak, see IEEE 802.3ae-2002, clause 47.3.4
Jitter tolerance, deterministic	$TOL_{DJ}$	0.37			UI	Measured peak-to-peak, see IEEE 802.3ae-2002, clause 47.3.4
Jitter tolerance, deterministic plus random jitter	$TOL_{DJ+RJ}$	0.55			UI	Measured peak-to-peak, see IEEE 802.3ae-2002, clause 47.3.4

1. Limited sample size tested under nominal conditions.

**Figure 64 • XAUI Receiver Input Sinusoidal Jitter Tolerance**

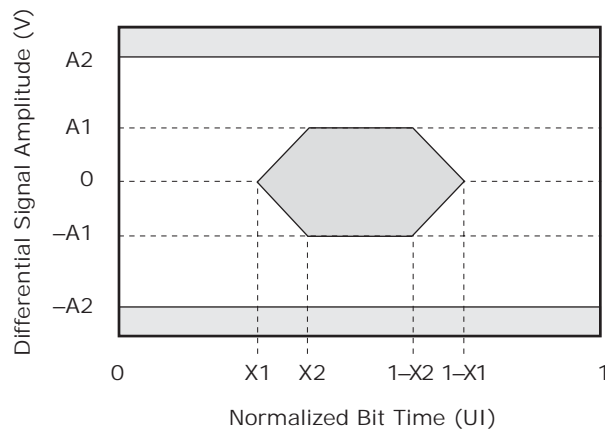


The following table shows the XAUI output specifications for the VSC8486-04 device.

**Table 305 • XAUI Output Specifications**

Parameter	Symbol	Minimum	Typical	Maximum	Unit	Condition
Output baud rate	$f$	3.125 – 100 ppm		3.1875 + 100 ppm	Gbps	
Unit interval	UI		320		ps	3.125 Gbps – 100 ppm to 3.1875 Gbps + 100 ppm.
Differential output voltage	$XV_{OUT\_DIFF}$	100		800	mV	Single-ended, AC-coupled. Measured peak-to-peak at far end, both sides driven with no offset applied. HISWNG = 0.
Output impedance <sup>1</sup>	$Z_{OUT}$		98		$\Omega$	Differential.
Differential output return loss <sup>1</sup>	$RLO_{DIFF}$		10		dB	100 MHz to 781.25 MHz, reducing 20 dB per decade up to 3.5 GHz. Includes on-chip circuitry, packaging, and off-chip components. 100 $\Omega$ test source.
Common-mode output return loss <sup>1</sup>	$RLO_{CM}$		6		dB	100 MHz to 2.5 GHz over valid output levels. Includes on-chip circuitry, packaging, and off-chip components. 25 $\Omega$ test source.
Total jitter	$T_J$			0.55	UI	Measured peak-to-peak at far end template.
Deterministic jitter	DJ			0.37	UI	Measured peak-to-peak at far end template.
Eye mask (X1)	X1			0.275	UI	Measured at far end template. See <a href="#">Figure 65</a> , page 198.
Eye mask (X2)	X2			0.40	UI	Measured at far end template. See <a href="#">Figure 65</a> , page 198.
Eye mask (A1)	A1	100			mV	HISWNG = 0. Measured at far end template. See <a href="#">Figure 65</a> , page 198.
Eye mask (A2)	A2			800	mV	HISWNG = 0. Measured at far end template. See <a href="#">Figure 65</a> , page 198.

1. Limited sample size tested under nominal conditions.

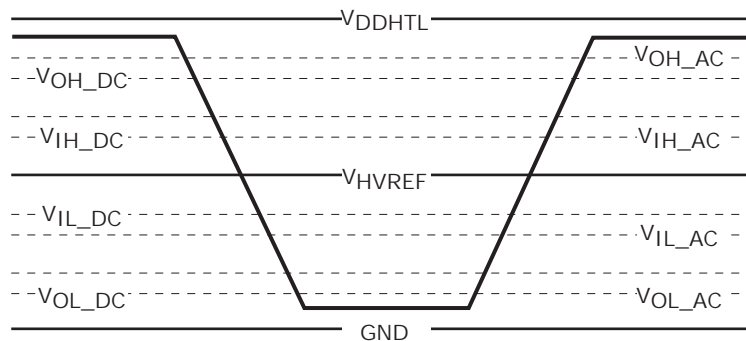
**Figure 65 • XAUI Output Compliance Mask**

### 5.2.3 XGMII Specifications

The following table shows the XGMII input specifications for the VSC8486-04 device.

**Table 306 • XGMII Input Specifications**

Parameter	Symbol	Minimum	Typical	Maximum	Unit	Condition
Input reference voltage	$V_{HVREF}$	0.68	0.75	0.9	V	Measured peak-to-peak. AC noise on $V_{HVREF}$ may not exceed 2% $V_{HVREF}(DC)$ .
DC input high voltage	$V_{IH\_DC}$	$V_{HVREF} + 0.1$		$V_{DDHTL}$	V	
DC input low voltage	$V_{IL\_DC}$	0		$V_{HVREF} - 0.1$	V	
AC input high voltage	$V_{IH\_AC}$	$V_{HVREF} + 0.2$			V	
AC input low voltage	$V_{IL\_AC}$			$V_{HVREF} - 0.2$	V	

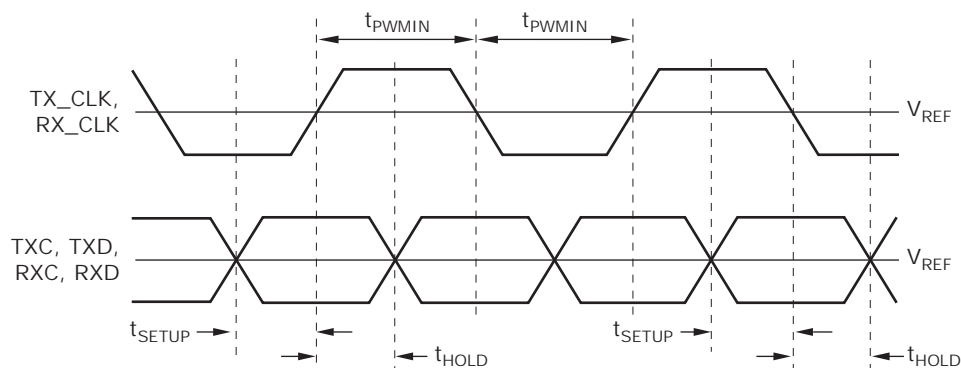
**Figure 66 • XGMII Input/Output Level Reference Diagram**

The following table shows the XGMII output specifications for the VSC8486-04 device.

**Table 307 • XGMII Output Specifications**

Parameter	Symbol	Minimum	Maximum	Unit	Condition
DC output high voltage	$V_{OH}$	$V_{DDHTL} - 0.4$		V	$I_{OH} = 8 \text{ mA}$ ( $V_{TT} = V_{DDHTL} / 2$ , $R_T = 50 \Omega$ )
DC output low voltage	$V_{OL}$		0.4	V	$I_{OH} =  -8 \text{ mA} $ ( $V_{TT} = V_{DDHTL} / 2$ , $R_T = 50 \Omega$ )
RXCLK output duty cycle	$DC_{RXCLK}$	45	55	%	

**Figure 67 • XGMII Interface Timing Diagram**



## 5.2.4 Timing and Reference Clock

The following tables show the timing and reference clock specifications for the VSC8486-04 device.

**Table 308 • Reset Timing**

Parameter	Symbol	Minimum	Unit	Condition
Minimum reset pulse width	$T_{RESET}$	0.1	$\mu\text{s}$	All power supplies are stable

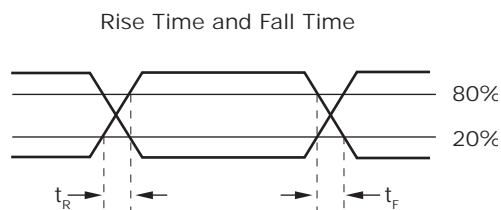
**Table 309 • Reference Clock Specifications**

Parameter	Symbol	Minimum	Maximum	Unit	Condition
REFCK frequency	$f_{REFCLK}$	153.00 MHz – 100 ppm	159.37 MHz + 100 ppm	MHz	Pins: REFSEL[1:0] = 00
REFCKP/N duty cycle	$DC_{REFCK}$	40	60	%	

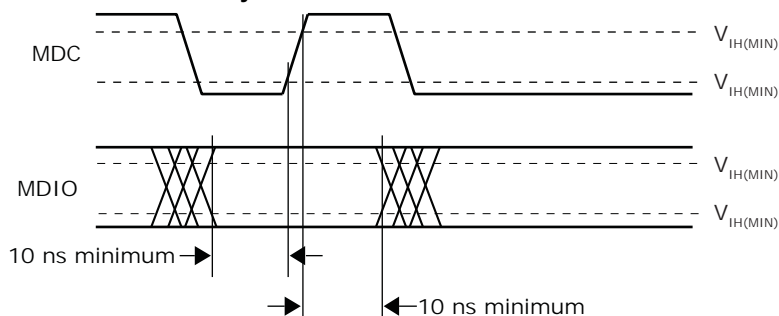
**Table 310 • TXCLK and RXCLK Timing Parameters**

Parameter	Symbol	Driver	Receiver	Unit
Setup time	$t_{SETUP}$	960	480	ps
Hold time	$t_{HOLD}$	960	480	ps
Minimum pulse width	$t_{PWMIN}$	2.5		ns

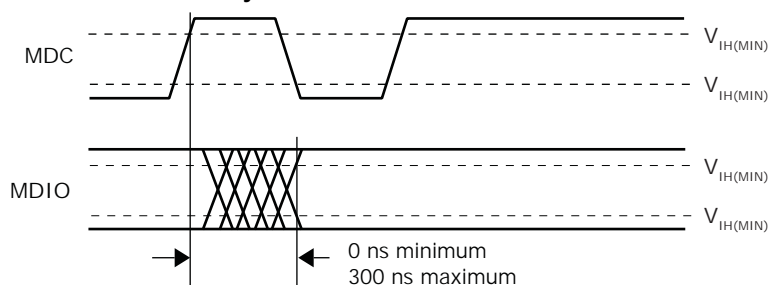
**Figure 68 • Parametric Measurement Setup**



**Figure 69 • Timing with MDIO Sourced by STA**



**Figure 70 • Timing with MDIO Sourced by MMD**



## 5.3 Operating Conditions

The following table shows the recommended operating conditions for the VSC8486-04 device.

To ensure that the control pins remain set to the desired configured state when the VSC8486-04 device is powered up, it is required to perform a reset through the reset pin after power-up and after the control pins are steady for 1 ms.

**Table 311 • Recommended Operating Conditions**

Parameter	Symbol	Minimum	Typical	Maximum	Unit	Condition
1.5 V power supply voltage	$V_{DDHTL}$	1.43	1.5	1.58	V	
1.5 V power supply current	$I_{DDHTL}$		150		mA	Outputs terminated 50 $\Omega$ to $V_{REF}$ , data toggling with 50% duty cycle
			10			Outputs unterminated, data toggling with 50% duty cycle
			1			Outputs unterminated, static data

**Table 311 • Recommended Operating Conditions (continued)**

Parameter	Symbol	Minimum	Typical	Maximum	Unit	Condition
1.2 V power supply voltage	$V_{DD12RX}$ $V_{DD12TX}$ $V_{DDA12}$ $V_{DD12X}$ $V_{DD12PCS}$	1.14	1.2	1.26	V	
1.2 V power supply current	$I_{DD12}$		625		mA	$V_{DDHTL} = \text{ground}$ . XAUI to 10 gigabit data in LAN mode
Power consumption at 1.2 V power supply	$P_{DD12}$		753 839	998 1130	mW	XAUI to XFI in LAN XAUI to XFI in WAN
TTL I/O power supply voltage	$V_{DDTTL}$	3.14 2.38 1.71 1.43 1.14	3.3 2.5 1.8 1.5 1.2	3.47 2.63 1.89 1.58 1.26	V	$V_{DDTTL} = 3.3\text{ V}$ $V_{DDTTL} = 2.5\text{ V}$ $V_{DDTTL} = 1.8\text{ V}$ $V_{DDTTL} = 1.5\text{ V}$ $V_{DDTTL} = 1.2\text{ V}$
TTL I/O power supply current	$I_{DDTTL}$		3		mA	$V_{DDTTL} = 3.3\text{ V}, 2.5\text{ V}, 1.8\text{ V}, 1.5\text{ V}$
Operating temperature <sup>1</sup>	T	-40		95	°C	

1. Minimum specification is ambient temperature, and the maximum is case temperature.

## 5.4 Stress Ratings

This section contains the stress ratings for the VSC8486-04 device.

**Warning** Stresses listed in the following table may be applied to devices one at a time without causing permanent damage. Functionality at or exceeding the values listed is not implied. Exposure to these values for extended periods may affect device reliability

**Table 312 • Stress Ratings**

Parameter	Symbol	Minimum	Maximum	Unit
3.3 V power supply voltage, potential to ground	$V_{DDTTL}$	-0.5	3.8	V
2.5 V power supply voltage, potential to ground	$V_{DDTTL}$	-0.5	2.9	V
1.8 V power supply voltage, potential to ground	$V_{DDTTL}$	-0.5	2.1	V
1.5 V power supply voltage, potential to ground	$V_{DDHTL}$	-0.5	1.9	V
1.2 V power supply voltage, potential to ground	$V_{DD12}$	-0.5	1.32	V
DC input voltage	$V_I$	-0.3	$V_{DDTTL}$ , $V_{DDHTL}$ , or $V_{DD12} + 0.3$	V
Output current (LVTTTL)	$I_{O\_VDDTTL}$	-16	16	mA
Absolute XAUI output voltage	$V_{XAUI\_ABS}$	-0.4	2.3	V
Storage temperature	$T_S$	-65	150	°C
Electrostatic discharge voltage, charged device model	$V_{ESD\_CDM}$	-200	200	V
Electrostatic discharge voltage, human body model	$V_{ESD\_HBM}$	-1000	1000	V

**Warning** This device can be damaged by electrostatic discharge (ESD) voltage. Microsemi recommends that all integrated circuits be handled with appropriate precautions. Failure to observe proper handling and installation procedures may adversely affect reliability of the device.

## 6 Pin Descriptions

The VSC8486-04 device has 256 pins, which are described in this section.



The pin information is also provided as an attached Microsoft Excel file, so that you can copy it electronically. In Adobe Reader, double-click the attachment icon.

### 6.1 Pin Diagram

The following illustration shows the pin diagram for the VSC8486-04 device, as seen from the top view.

Figure 71 • Pin Diagram

	1	2	3	4	5	6	7	8	9	10	11	12	13	14	15	16
A	NC	REFCKP	VSS	TXD1	TXD5	TXD8	TXD12	TXC1	TXD18	TXD22	XTX3N	XTX3P	TXD27	XR3N	XR3P	NC
B	REFCKN	REFTERM	VSS	TXD0	TXD4	TXC0	TXD11	TXD15	TXD17	TXD21	TXC2	TXD25	TXD26	TXD29	TXD30	TXD31
C	VSS	VSS	VSS	RXALARM	TXD3	TXD7	TXD10	TXD14	TXD16	TXD20	TXD23	TXD24	HVREF	TXD28	TXC3	XTX2N
D	WREFCKP	VSS	VSS	VREFCKP	TXD2	TXD6	TXD9	TXD13	TXCLK	TXD19	WIS_INTA	FORCEAIS	LOPC	CLK64A_EN	LP_XAUI	XTX2P
E	WREFCKN	VSS	CMUFILT	TXALARM	LASI	NC	REFSELO	SPLITLOOPN	NC	TXONOFFI	VSS	VSS	LPP_10B	LP_16B	LP_XGMII	NC
F	VSS	VSS	NC	VREFCKN	VSS	PMTICK	NC	NC	RFPOUT	VSS	VDDA12	VDDA12	VSS	WANMODE	XAUIFILT	XR2N
G	VSS	VSS	EXVCD0N	VDD12TX	VSS	VDDTTL	VSS	VDDHTL	VDD12PCS	VSS	VDDA12	VDDA12	VSS	VDD12X	VSS	XR2P
H	TXDOUTP	VSS	VSS	VDD12TX	VDD12TX	VDD12RX	VSS	VDDHTL	VDDHTL	VSS	VDDA12	VDDA12	VSS	VDD12X	RCLKOUT	VSS
J	TXDOUTN	VSS	CLK64AP	CLK64BP	CLK64BN	VDD12RX	VSS	VDDHTL	VDDHTL	VSS	VDDA12	VDDA12	VSS	VDD12X	RDAOUT	VSS
K	VSS	VSS	CLK64AN	VSS	VSS	VDDTTL	VSS	VDDHTL	VDD12PCS	VSS	VDDA12	TCLKOUT	VSS	VDD12X	VSS	XTX1N
L	CRUFILT	VSS	VSS	M DIO	VSS	WIS_INTB	MDC	RESETN	MSTCODE2	MSTCODE1	VDDA12	TDAIN	VSS	VDD12X	NC	XTX1P
M	VSS	VSS	EXVCOU1P	EXVCD0N1P	RXINOFFEN	STWSDA	STWSCL	PRTAD4	PRTAD3	MSTCODE0	VSS	VSS	EPCS	NC	TFPOUT	IOMODESEL
N	RXINP	VSS	RXINCM	TMS	RXD2	RXD6	RXD9	RXD13	RXCLK	RXD19	PRTAD2	PRTAD1	PRTAD0	AUTONEG	NC	XR1N
P	RXINN	EXVCOU1N	VSS	TDI	RXD3	RXD7	RXD10	RXD14	RXD16	RXD20	RXD23	RXD24	STWWP	RXD28	RXC3	XR1P
R	VSS	NC	TDO	RXD0	RXD4	RXC0	RXD11	RXD15	RXD17	RXD21	RXC2	RXD25	RXD26	RXD29	RXD30	RXD31
T	NC	TRSTB	TCK	RXD1	RXD5	RXD8	RXD12	RXC1	RXD18	RXD22	XR0P	XR0N	RXD27	XTX0P	XTX0N	NC

### 6.2 Pins by Function

This section contains the functional pin descriptions for the VSC8486-04 device.



## 6.2.1 XFI 10-Gigabit Data Bus Interface

The following table lists the pins associated with the XFI interface.

**Table 313 • XFI 10-Gigabit Data Bus Pins**

Name	Number	I/O	Type	Description
RXINCM	N3		Analog	Rx 10-gigabit serial data input resistor termination center tap
RXINN	P1	I	CML	Rx 10-gigabit serial data input, complement
RXINP	N1	I	CML	Rx 10-gigabit serial data input, true
TXDOUTN	J1	O	CML	Tx 10-gigabit serial data output, complement
TXDOUTP	H1	O	CML	Tx 10-gigabit serial data output, true

## 6.2.2 XAUI 10-Gigabit Data Bus Interface

The following table lists the pins associated with the XAUI interface.

**Table 314 • XAUI 10-Gigabit Data Bus Pins**

Name	Number	I/O	Type	Description
XAUIFILT	F15		Analog	XAUI CMU filter capacitor (1 $\mu$ F) from this pin to ground.
XRX0N	T12	I	CML	XAUI channel 0 serial data input, complement. DL0<N> as specified in IEEE 802.3ae.
XRX0P	T11	I	CML	XAUI channel 0 serial data input, true. DL0<P> as specified in IEEE 802.3ae.
XRX1N	N16	I	CML	XAUI channel 1 serial data input, complement. DL1<N> as specified in IEEE 802.3ae.
XRX1P	P16	I	CML	XAUI channel 1 serial data input, true. DL1<P> as specified in IEEE 802.3ae.
XRX2N	F16	I	CML	XAUI channel 2 serial data input, complement. DL2<N> as specified in IEEE 802.3ae.
XRX2P	G16	I	CML	XAUI channel 2 serial data input, true. DL2<P> as specified in IEEE 802.3ae.
XRX3N	A14	I	CML	XAUI channel 3 serial data input, complement. DL3<N> as specified in IEEE 802.3ae.
XRX3P	A15	I	CML	XAUI channel 3 serial data input, true. DL3<P> as specified in IEEE 802.3ae.
XTX0N	T15	O	CML	XAUI channel 0 serial data output, complement. SL0<N> as specified in IEEE 803.3ae.
XTX0P	T14	O	CML	XAUI channel 0 serial data output, true. SL0<P> as specified in IEEE 803.3ae.
XTX1N	K16	O	CML	XAUI channel 1 serial data output, complement. SL1<N> as specified in IEEE 802.3ae.
XTX1P	L16	O	CML	XAUI channel 1 serial data output, true. SL1<P> as specified in IEEE 802.3ae.
XTX2N	C16	O	CML	XAUI channel 2 serial data output, complement. SL2<N> as specified in IEEE 802.3ae.
XTX2P	D16	O	CML	XAUI channel 2 serial data output, true. SL2<P> as specified in IEEE 803.3ae.

**Table 314 • XAUI 10-Gigabit Data Bus Pins (continued)**

Name	Number	I/O	Type	Description
XTX3N	A11	O	CML	XAUI channel 3 serial data output, complement. SL3<N> as specified in IEEE 802.3ae.
XTX3P	A12	O	CML	XAUI channel 3 serial data output, true. SL3<P> as specified in IEEE 802.3ae.

### 6.2.3 XGMII 10-Gigabit Data Bus Interface

The following table lists the pins associated with the XGMII interface.

**Table 315 • XGMII 10-Gigabit Data Bus Pins**

Name	Number	I/O	Type	Description
HVREF	C13		Analog	HSTL I/O reference input voltage.
RXC0	R6	O	HSTL	XGMII control bit for lane 0 (bits 0–7).
RXC1	T8	O	HSTL	XGMII control bit for lane 1 (bits 8–15).
RXC2	R11	O	HSTL	XGMII control bit for lane 2 (bits 16–23).
RXC3	P15	O	HSTL	XGMII control bit for lane 3 (bits 24–31).
RXCLK	N9	O	HSTL	Double data rate reference for the transfer of RXD<31:0> and RXC<3:0> signals.
RXD0	R4	O	HSTL	XGMII output (lane 0; bit 0).
RXD1	T4	O	HSTL	XGMII output (lane 0; bit 1).
RXD10	P7	O	HSTL	XGMII output (lane 1; bit 2).
RXD11	R7	O	HSTL	XGMII output (lane 1; bit 3).
RXD12	T7	O	HSTL	XGMII output (lane 1; bit 4).
RXD13	N8	O	HSTL	XGMII output (lane 1; bit 5).
RXD14	P8	O	HSTL	XGMII output (lane 1; bit 6).
RXD15	R8	O	HSTL	XGMII output (lane 1; bit 7).
RXD16	P9	O	HSTL	XGMII output (lane 2; bit 0).
RXD17	R9	O	HSTL	XGMII output (lane 2; bit 1).
RXD18	T9	O	HSTL	XGMII output (lane 2; bit 2).
RXD19	N10	O	HSTL	XGMII output (lane 2; bit 3).
RXD2	N5	O	HSTL	XGMII output (lane 0; bit 2).
RXD20	P10	O	HSTL	XGMII output (lane 2; bit 4).
RXD21	R10	O	HSTL	XGMII output (lane 2; bit 5).
RXD22	T10	O	HSTL	XGMII output (lane 2; bit 6).
RXD23	P11	O	HSTL	XGMII output (lane 2; bit 7).
RXD24	P12	O	HSTL	XGMII output (lane 3; bit 0).
RXD25	R12	O	HSTL	XGMII output (lane 3; bit 1).
RXD26	R13	O	HSTL	XGMII output (lane 3; bit 2).
RXD27	T13	O	HSTL	XGMII output (lane 3; bit 3).
RXD28	P14	O	HSTL	XGMII output (lane 3; bit 4).
RXD29	R14	O	HSTL	XGMII output (lane 3; bit 5).

**Table 315 • XGMII 10-Gigabit Data Bus Pins (continued)**

Name	Number	I/O	Type	Description
RXD3	P5	O	HSTL	XGMII output (lane 0; bit 3).
RXD30	R15	O	HSTL	XGMII output (lane 3; bit 6).
RXD31	R16	O	HSTL	XGMII output (lane 3; bit 7).
RXD4	R5	O	HSTL	XGMII output (lane 0; bit 4).
RXD5	T5	O	HSTL	XGMII output (lane 0; bit 5).
RXD6	N6	O	HSTL	XGMII output (lane 0; bit 6).
RXD7	P6	O	HSTL	XGMII output (lane 0; bit 7).
RXD8	T6	O	HSTL	XGMII output (lane 1; bit 0).
RXD9	N7	O	HSTL	XGMII output (lane 1; bit 1).
TXC0	B6	I	HSTL	XGMII control bit for lane 0 (bits 0–7).
TXC1	A8	I	HSTL	XGMII control bit for lane 1 (bits 8–15).
TXC2	B11	I	HSTL	XGMII control bit for lane 2 (bits 16–23).
TXC3	C15	I	HSTL	XGMII control bit for lane 3 (bits 24–31).
TXCLK	D9	I	HSTL	Timing reference for the clocking TXD<31:0> and TXC<3:0> signals. Data is sampled using both positive and negative edges of TXCLK.
TXD0	B4	I	HSTL	XGMII input (lane 0; bit 0).
TXD1	A4	I	HSTL	XGMII input (lane 0; bit 1).
TXD10	C7	I	HSTL	XGMII input (lane 1; bit 2).
TXD11	B7	I	HSTL	XGMII input (lane 1; bit 3).
TXD12	A7	I	HSTL	XGMII input (lane 1; bit 4).
TXD13	D8	I	HSTL	XGMII input (lane 1; bit 5).
TXD14	C8	I	HSTL	XGMII input (lane 1; bit 6).
TXD15	B8	I	HSTL	XGMII input (lane 1; bit 7).
TXD16	C9	I	HSTL	XGMII input (lane 2; bit 0).
TXD17	B9	I	HSTL	XGMII input (lane 2; bit 1).
TXD18	A9	I	HSTL	XGMII input (lane 2; bit 2).
TXD19	D10	I	HSTL	XGMII input (lane 2; bit 3).
TXD2	D5	I	HSTL	XGMII input (lane 0; bit 2).
TXD20	C10	I	HSTL	XGMII input (lane 2; bit 4).
TXD21	B10	I	HSTL	XGMII input (lane 2; bit 5).
TXD22	A10	I	HSTL	XGMII input (lane 2; bit 6).
TXD23	C11	I	HSTL	XGMII input (lane 2; bit 7).
TXD24	C12	I	HSTL	XGMII input (lane 3; bit 0).
TXD25	B12	I	HSTL	XGMII input (lane 3; bit 1).
TXD26	B13	I	HSTL	XGMII input (lane 3; bit 2).
TXD27	A13	I	HSTL	XGMII input (lane 3; bit 3).
TXD28	C14	I	HSTL	XGMII input (lane 3; bit 4).
TXD29	B14	I	HSTL	XGMII input (lane 3; bit 5).

**Table 315 • XGMII 10-Gigabit Data Bus Pins (continued)**

Name	Number	I/O	Type	Description
TXD3	C5	I	HSTL	XGMII input (lane 0; bit 3).
TXD30	B15	I	HSTL	XGMII input (lane 3; bit 6).
TXD31	B16	I	HSTL	XGMII input (lane 3; bit 7).
TXD4	B5	I	HSTL	XGMII input (lane 0; bit 4).
TXD5	A5	I	HSTL	XGMII input (lane 0; bit 5).
TXD6	D6	I	HSTL	XGMII input (lane 0; bit 6).
TXD7	C6	I	HSTL	XGMII input (lane 0; bit 7).
TXD8	A6	I	HSTL	XGMII input (lane 1; bit 0).
TXD9	D7	I	HSTL	XGMII input (lane 1; bit 1).

## 6.2.4 Serial Bus Interface

The following table lists the pins associated with the serial bus interface.

**Table 316 • Serial Bus Interface Pins**

Name	Number	I/O	Type	Description
MDC	L7	I	LVTTTL	Management data clock. Schmitt trigger.
MDIO	L4	I/O	LVTTTL (open drain)	Management data bus bidirectional I/O. Requires external pull-up resistor (nominally 4.7 k $\Omega$ ).
MSTCODE0	M10	I	LVTTTL	Two-wire serial interface master code, bit 0. Can also be used as general purpose input.
MSTCODE1	L10	I	LVTTTL	Two-wire serial interface master code, bit 1 or alternate XFP alarm input, internally pulled low. Can also be used as general purpose input.
MSTCODE2	L9	I	LVTTTL	Two-wire serial interface master code, bit 2 or alternate XFP alarm input, internally pulled low. Can also be used as general purpose input.
RCLKOUT	H15	O	LVTTTL	WIS overhead receive serial data clock.
RDAOUT	J15	O	LVTTTL	WIS overhead port receive serial data.
RFPOUT	F9	O	LVTTTL	WIS overhead port receive frame pulse.
STWSCL	M7	I	LVTTTL	Two-wire serial interface clock. Requires external pull-up resistor nominally 4.7 k $\Omega$ .
STWSDA	M6	I/O	LVTTTL	Serial input/output data for the two-wire serial interface. Requires external pull-up resistor, nominally 4.7 k $\Omega$ .
STWWP	P13	I	LVTTTL	Two-wire serial interface write protect. 0: Enable writes to two-wire serial slave. 1: Disable writes to two-wire serial slave. Internally pulled up.
TCLKOUT	K12	O	LVTTTL	WIS overhead port transmit serial data clock
TDAIN	L12	I	LVTTTL	WIS overhead port transmit serial data.
TFPOUT	M15	O	LVTTTL	WIS overhead port transmit frame pulse.

## 6.2.5 Input and Output Reference Clocks

The following table lists the pins associated with reference clocks.

**Table 317 • Input and Output Reference Clock Pins**

Name	Number	I/O	Type	Description
CLK64A_EN	D14	I	LVTTTL	CLK64A enable. 1: CLK64A enabled (default, internally pulled up). 0: CLK64A disabled.
CLK64AN	K3	O	CML	Selectable clock, complement. CMU divided by 64, or CMU divided by 66, or CRU divided by 64, or REFCK. Default is CMU divided by 64. Normally used for XFP reference clock.
CLK64AP	J3	O	CML	Selectable clock, true. CMU divided by 64, or CMU divided by 66, or CRU divided by 64, or REFCK. Default is CMU divided by 64. Normally used for XFP reference clock.
CLK64BN	J5	O	CML	Selectable clock, complement. CMU divided by 64, or CMU divided by 66, or CRU divided by 64, or TEST_CLK. Default is CRU divided by 64 when enabled.
CLK64BP	J4	O	CML	Selectable clock, true. CMU divided by 64, or CMU divided by 66, or CRU divided by 64, or TEST_CLK. Default is CRU divided by 64 when enabled.
REFCKN	B1	I	LVPECL	Reference clock input, complement. Terminated 50 $\Omega$ to REFTERM.
REFCKP	A2	I	LVPECL	Reference clock input, true. Terminated 50 $\Omega$ to REFTERM.
REFSEL0	E7	I	LVTTTL	WAN mode WREFCLK frequency select. 0: 622.08 MHz (default, internally pulled low). 1: 155.52 MHz.
REFTERM	B2	I	LVPECL	Reference clock input termination center tap.
VREFCKN	F4	I	LVPECL	WAN VCO reference clock, complement. The 10-gigabit CMU reference clock for WANMODE. 622.08 MHz VCISO input used in conjunction with external jitter attenuation PLL.
VREFCKP	D4	I	LVPECL	WAN VCO reference clock, true. The 10-gigabit CMU reference clock for WANMODE. 622.08 MHz VCISO input used in conjunction with external jitter attenuation PLL.
WREFCKN	E1	I	LVPECL	WAN reference clock, complement. Can be 155.52 MHz or 622.08 MHz. 622.08 MHz must be used for optimum jitter generation performance.
WREFCKP	D1	I	LVPECL	WAN Reference clock, true. Can be 155.52 MHz or 622.08 MHz. 622.08 MHz must be used for optimum jitter generation performance.

## 6.2.6 Status and Control

The following table lists the pins that issue status or enable various modes.

**Table 318 • Status and Control Pins**

Name	Number	I/O	Type	Description
AUTONEG	N14	I	LVTTTL	Auto-negotiate enable. Adjusts Tx encoder to match Rx input data. 0: Device resets to state set by EPCS pin. 1: Device will auto-negotiate enhanced or standard PCS. Internally pulled low.
EPCS	M13	I	LVTTTL	Extended-PCS enable. Sets start-up transmit encoder to E-PCS. 0: Device resets to IEEE standard PCS encoding 64/66B. 1: Device resets to EPCS encoding OIF-CEI “firecode.” Internally pulled low.
FORCEAIS	D12	I	LVTTTL	When asserted, forces the receive WIS into an AIS-L state.
IOMODESEL	M16	I	LVTTTL	Parallel interface mode selection pin. 0: XGMII (default, internally pulled low). 1: XAUI.
LASI	E5	O	LVTTTL (open drain)	Link alarm status interrupt. Logical OR for RXALARM, TXALARM and LSALARM and as enabled by register 1E×9002. Open-drain output requires external pull-up resistor.
LOPC	D13	I	LVTTTL	Loss of optical carrier normally connected to XFP RX_LOS output.
LP_16B	E14	I	LVTTTL	Reserved for factory test only. Internally pulled low by default.
LPP_10B	E13	I	LVTTTL	Reserved for factory test only. Internally pulled low by default.
LP_XAUI	D15	I	LVTTTL	Simultaneous enable for system and network loopback paths B and D, respectively. 0: Normal operation. 1: Loopbacks B and D enabled. Internally pulled low.
LP_XGMII	E15	I	LVTTTL	Selects PCS and XGXS data source. 0: PCS source from XGXS, XGXS source from PCS. 1: PCS source from XGMII, XGXS source from XGMII. Internally pulled low.
PMTICK	F6	I	LVTTTL	WIS block counter sampling time control.
PRTAD0	N13	I	LVTTTL	Port address bit 0 (LOW = 0). Internally pulled down.
PRTAD1	N12	I	LVTTTL	Port address bit 1 (LOW = 0). Internally pulled down.
PRTAD2	N11	I	LVTTTL	Port address bit 2 (LOW = 0). Internally pulled down.
PRTAD3	M9	I	LVTTTL	Port address bit 3 (LOW = 0). Internally pulled low
PRTAD4	M8	I	LVTTTL	Port address bit 4 (LOW = 0). Internally pulled low
RESETN	L8	I	LVTTTL	Global chip reset. Active LOW. Schmitt trigger. Internally pulled up. Reset is required after power up for proper operation.

**Table 318 • Status and Control Pins (continued)**

Name	Number	I/O	Type	Description
RXALARM	C4	O	LVTTTL (open drain)	Logical OR for alarms in register 1E×9003 and as enabled by register 1E×9000. Open-drain output requires external pull-up resistor.
RXINOFFEN	M5	I	LVTTTL	10-gigabit PMA input receiver DC offset correction loop enable. 0: Disable DC correction loop. 1: Enable DC correction loop. Internally pulled low.
SPLITLOOP N	E8	I	LVTTTL	Enables simultaneous system and network loopback paths J and K, respectively. 1: Normal operation. 0: Loopbacks J and K enabled. Internally pulled high.
TXALARM	E4	O	LVTTTL (open drain)	Logical OR for alarms in register 1E×9004 and as enabled by register 1E×9001. Open-drain output requires external pull-up resistor. Alternate GPO or Tx link/activity LED driver.
TXONOFFI	E10	I	LVTTTL	Transmitter data mute. When set HIGH, transmitter is enabled. When set LOW, transmitter is disabled. Internally pulled up. Internal Schmitt trigger.
WANMODE	F14	I	LVTTTL	WAN mode select. 0: LAN mode (default). 1: WAN mode. This can be overridden by setting 1×E605.3=1 and 1×E605.2=0.
WIS_INTA	D11	O	LVTTTL (open drain)	WIS interrupt A, part of extended WIS. Open-drain output requires external pull-up resistor. Alternate GPO or LED driver.
WIS_INTB	L6	O	LVTTTL (open drain)	WIS interrupt B, part of extended WIS. Open-drain output requires external pull-up resistor. Alternate GPO or LED driver.

## 6.2.7 Phase Detector Outputs

The following table lists the pins associated with phase detector outputs.

**Table 319 • Phase Detector Output Pins**

Name	Number	I/O	Type	Description
EXVCOUP N	P2	O	CML	Internal phase frequency detector down, complement
EXVCOUPP	M3	O	CML	Internal phase frequency detector down, true
EXVCODN N	G3	O	CML	Internal phase frequency detector up, complement
EXVCODN P	M4	O	CML	Internal phase frequency detector up, true

## 6.2.8 Phase-Locked Loop Filter Capacitors

The following table lists the pins associated with phase-locked loop filter capacitors.

**Table 320 • Phase-Locked Loop Filter Capacitor Pins**

Name	Number	I/O	Type	Description
CMUFILT	E3		Analog	CMU filter connect capacitor (1 $\mu$ F) from this pin to ground
CRUFILT	L1		Analog	CRU filter capacitor (1 $\mu$ F) from this pin to ground

## 6.2.9 JTAG Interface

The following table lists the pins that control the JTAG test access port.

**Note:** The JTAG interface does not support XFI and XAUI I/O testing capability.

**Table 321 • JTAG Interface Pins**

Name	Number	I/O	Type	Description
TCK	T3	I	LVTTTL	JTAG test access port test clock input. Internally pulled up.
TDI	P4	I	LVTTTL	JTAG test access port test data input. Internally pulled up.
TDO	R3	O	LVTTTL	JTAG test access port test data output.
TMS	N4	I	LVTTTL	JTAG test access port test mode select input. Internally pulled up.
TRSTB	T2	I	LVTTTL	JTAG test access port test logic reset input. Internally pulled up. For TAP controller reset, this input must be pulled low. In normal operation, this pin should be connected to ground.

## 6.2.10 Power and Ground

The following table lists the pins used for power and ground.

**Table 322 • Power and Ground Pins**

Name	Number	I/O	Description
VDD12PCS	G9 K9	Power	1.2 V power supply (PCS).
VDD12RX	H6 J6	Power	1.2 V power for PMA serial 10-gigabit Rx.
VDD12TX	G4 H4 H5	Power	1.2 V power for PMA serial 10-gigabit Tx.
VDD12×	G14 H14 J14 K14 L14	Power	1.2 V power supply for XAUI I/O.



**Table 322 • Power and Ground Pins (continued)**

Name	Number	I/O	Description
VDDA12	F11 F12 G11 G12 H11 H12 J11 J12 K11 L11	Power	1.2 V analog power supply for XAUI I/O.
VDDHTL	G8 H8 H9 J8 J9 K8	Power	HSTL I/O 1.5 V power supply. Left open if XGMII is not used.
VDDTTL	G6 K6	Power	TTL power supply (1.2 V, 1.5 V, 1.8 V, or 3.3 V).
VSS	A3, B3, C1, C2, C3, D2, D3, E2, E11, E12, F1, F2, F5, F10, F13, G1, G2, G5, G7, G10, G13, G15, H2, H3, H7, H10, H13, H16, J2, J7, J10, J13, J16, K1, K2, K4, K5, K7, K10, K13, K15, L2, L3, L5, L13, M1, M2, M11, M12, N2, P3, R1	GND	Ground.

## 6.2.11 Miscellaneous Pins

The following table lists the miscellaneous pins used for the VSC8486-04 device.

**Table 323 • Miscellaneous**

<b>Name</b>	<b>Number</b>	<b>I/O</b>	<b>Description</b>
NC	A1, A16, E6, E9, E16, F3, F7, F8, L15, M14, N15, T1, T16	NC	No connect
NC	R2	NC	Internally connected to ground.

## 7 Package Information

---

The VSC8486-04 device is available in three package types. VSC8486SN-04 is a 256-pin, flip chip ball grid array (FCBGA) with a 17 mm × 17 mm body size, 1 mm pin pitch, and 3.22 mm maximum height. The device is also available in lead-free (Pb-free) packages, VSC8486XSN-04 and VSC8486YSN-04. Note that for VSC8486XSN-04, only the second-level interconnect is lead-free.

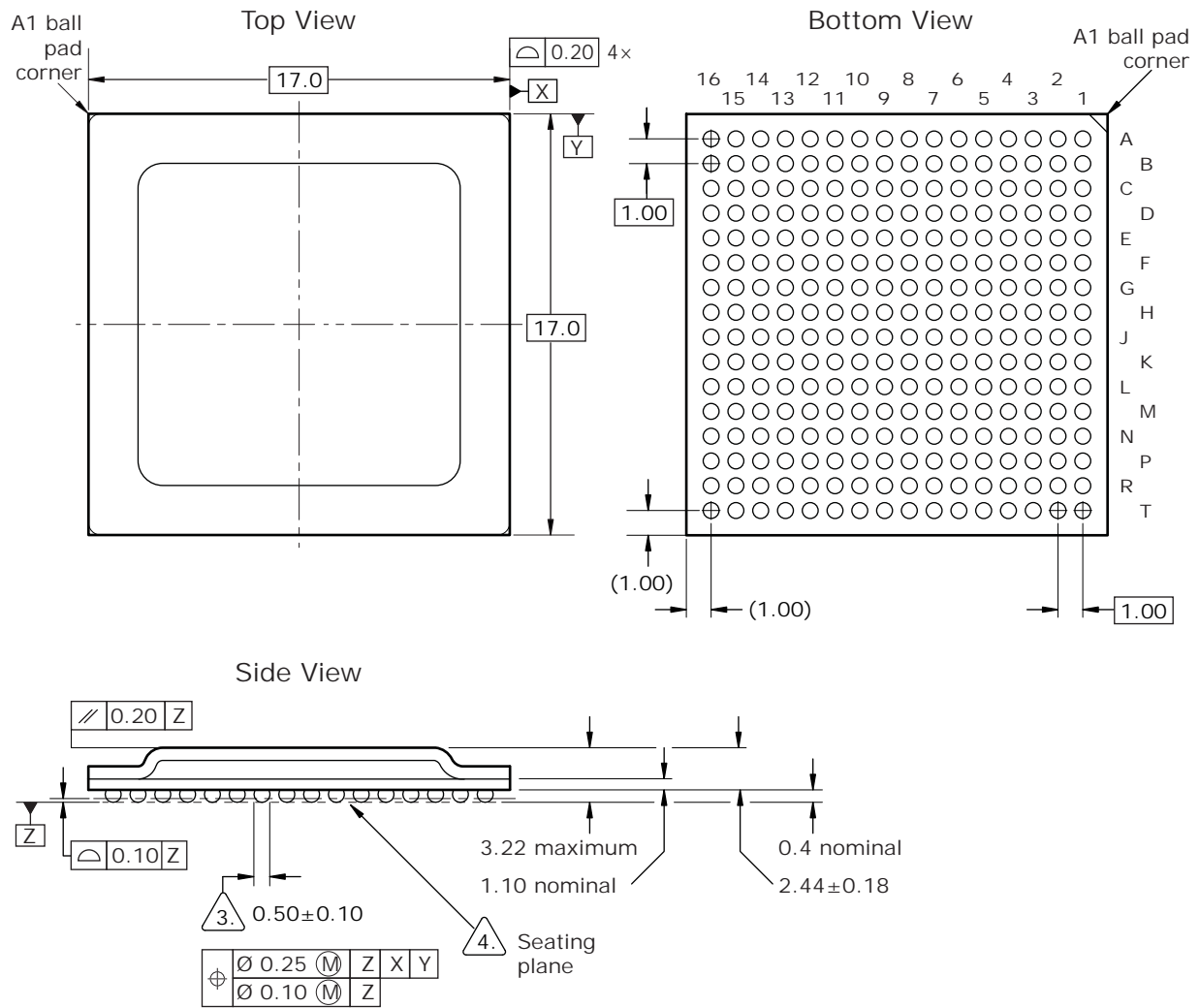
Lead-free products from Microsemi comply with the temperatures and profiles defined in the joint IPC and JEDEC standard IPC/JEDEC J-STD-020. For more information, see the IPC and JEDEC standard.

This section provides the package drawings, thermal specifications, and moisture sensitivity rating for the VSC8486-04 device.

### 7.1 Package Drawing

The following illustrations show the package drawings for the VSC8486-04 device. Each drawing contains the top view, bottom view, side view, dimensions, tolerances, and notes.

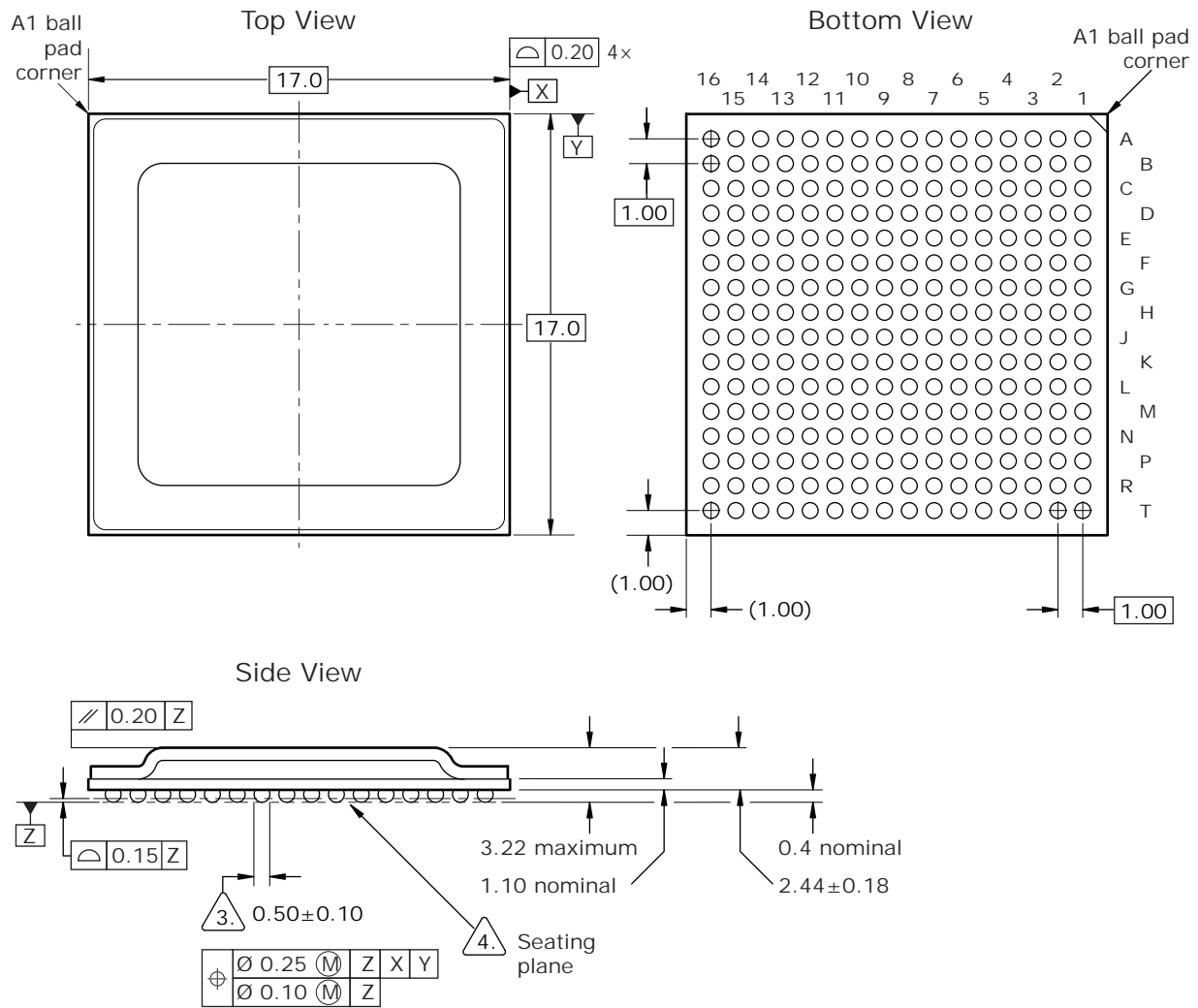
**Figure 72 • Package Drawing for VSC8486SN-04 and VSC8486XSN-04**



**Notes**

1. All dimensions and tolerances are in millimeters (mm).
2. The maximum solder ball matrix size is 16 mm × 16 mm.
3. Dimension is measured at the maximum solder ball diameter, parallel to primary datum Z.
4. Primary datum Z and seating plane are defined by the spherical crowns of the solder balls.
5. Radial true position is represented by typical values.

**Figure 73 • Package Drawing for VSC8486YSN-04**



**Notes**

1. All dimensions and tolerances are in millimeters (mm).
2. The maximum solder ball matrix size is 16 mm × 16 mm.
3. Dimension is measured at the maximum solder ball diameter, parallel to primary datum Z.
4. Primary datum Z and seating plane are defined by the spherical crowns of the solder balls.
5. Radial true position is represented by typical values.

## 7.1.1 Thermal Specifications

Thermal specifications for this device are based on the JEDEC standard EIA/JESD51-2 and have been modeled using a four-layer test board with two signal layers, a power plane, and a ground plane (2s2p PCB). For more information, see the JEDEC standard.

**Table 324 • Thermal Resistances**

Part Order Number	$\theta_{JC}$	$\theta_{JB}$	$\theta_{JA}$ ( $^{\circ}\text{C}/\text{W}$ ) vs. Airflow (ft/min)		
			0	100	200
VSC8486SN-04	0.9	12	18	16	14
VSC8486XSN-04	0.9	12	18	16	14
VSC8486YSN-04	0.9	12	18	16	14

To achieve results similar to the modeled thermal resistance measurements, the guidelines for board design described in the JEDEC standard EIA/JESD51 series must be applied. For information about specific applications, see the following:

EIA/JESD51-5, *Extension of Thermal Test Board Standards for Packages with Direct Thermal Attachment Mechanisms*

EIA/JESD51-7, *High Effective Thermal Conductivity Test Board for Leaded Surface Mount Packages*

EIA/JESD51-9, *Test Boards for Area Array Surface Mount Package Thermal Measurements*

EIA/JESD51-10, *Test Boards for Through-Hole Perimeter Leaded Package Thermal Measurements*

EIA/JESD51-11, *Test Boards for Through-Hole Area Array Leaded Package Thermal Measurements*

## 7.1.2 Moisture Sensitivity

This device is rated moisture sensitivity level 4 as specified in the joint IPC and JEDEC standard IPC/JEDEC J-STD-020. For more information, see the IPC and JEDEC standard.

## 8 Design Guidelines

This section provides recommended guidelines for designing with the VSC8486-04 device.

### 8.1 Power Supply Connection

In XAUI mode, the VSC8486-04 operates from a single 1.2 V power supply. If XGMII is used, a 1.5 V power supply is required for HSTL I/O only. A 3.3 V LVTTTL power supply is used to provide a compatible interface to other devices using low-speed LVTTTL I/O. There are no power supply sequence requirements for the VSC8486-04.

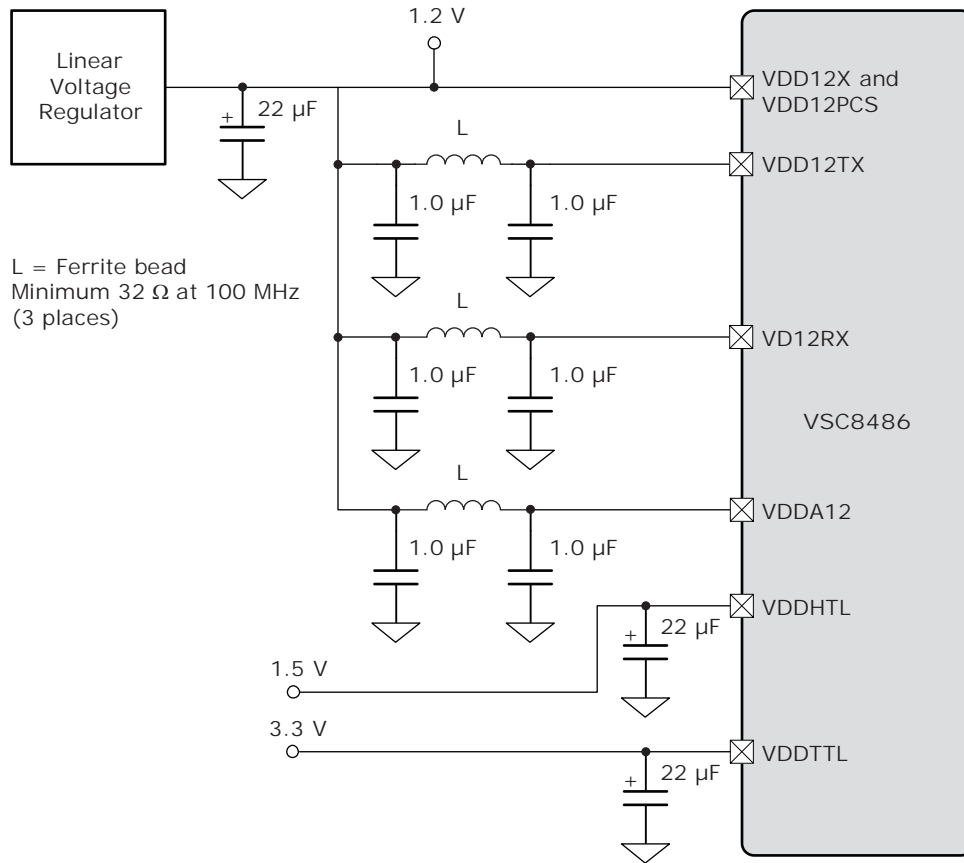
Functional power groups and associated pin locations are summarized in the following table.

**Table 325 • Power Supply and Pin Locations**

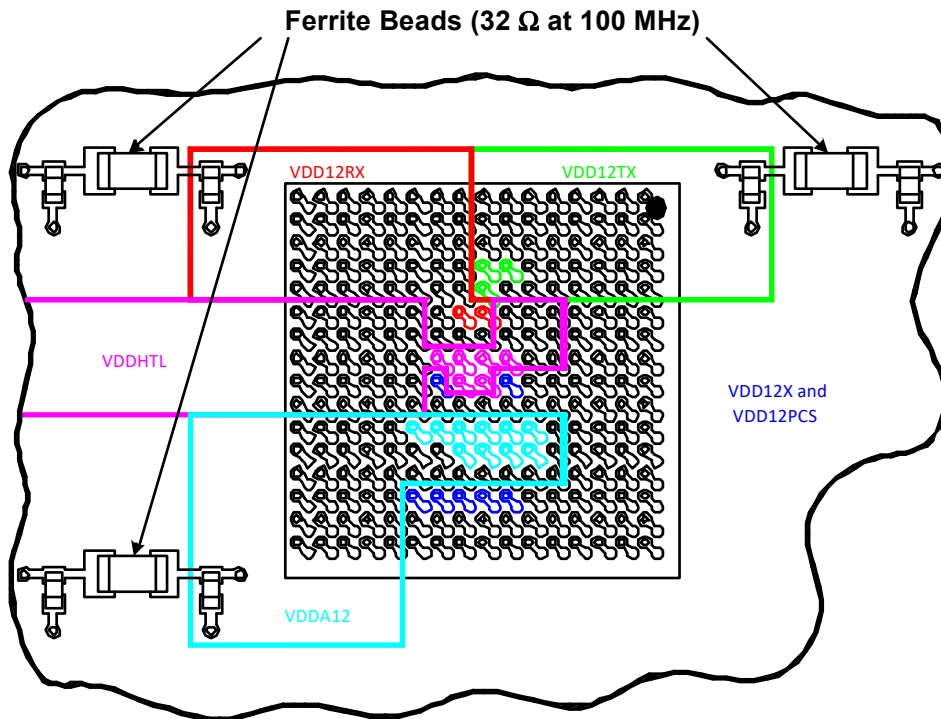
Power Supply (DC)	VSC8486-04 Subsystem	Group Name	Pin Locations	Typical Group Supply Current (LAN Mode)
1.2 V	10-gigabit VCO and Rx PLL	VDD12RX	H6, J6	110 mA
1.2 V	10-gigabit VCO and Tx PLL	VDD12TX	G4, H4, H5	65 mA
1.2 V	XAUI Analog and PLL	VDDA12	F11, F12, G11, G12, H11, H12, J11, J12, K11, L11	70 mA
1.2 V	XAUI	VDD12×	G14, H14, J14, K14, L14	100 mA
1.2 V	PCS	VDD12PCS	G9, K9	220 mA
1.5 V	HSTL I/O	VDDHTL	G8, H8, H9, J8, J9, K8	36 mA
3.3 V	LVTTTL I/O	VDDTTL	K6, G6	5 mA
GND		GND	A3, B3, C1, C2, C3, D2, D3, E2, E11, E12, F1, F2, F5, F10, F13, G1, G2, G5, G7, G10, G13, G15, H2, H3, H7, H10, H13, H16, J2, J7, J10, J13, J16, K1, K2, K4, K5, K7, K10, K13, K15, L2, L3, L5, L13, M1, M2, M11, M12, N2, P3, R1	Not applicable

The following illustration shows the recommended filter structures for the VSC8486-04 functional power supply groups. Although not illustrated, it is recommended that each power supply pin have a 0402 size, XR7 dielectric, 0.01  $\mu$ F ceramic capacitor. Place these capacitors in the pin field, close to the nearest ground pin to minimize connection traces and associated inductance. It is also recommended to isolate the different 1.2 V power supplies into four different islands on the same PCB layer.

**Figure 74 • Recommended Power Supply Isolation Schematic**



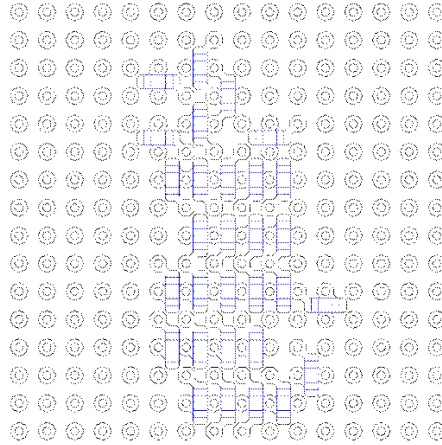
**Figure 75 • Split Plane Layout Example**





The following diagram shows an example of the 0402 size, 0.01  $\mu\text{F}$  decoupling capacitors, located in the pin field.

**Figure 76 • Decoupling Capacitor Placement Example**



## 9 Ordering Information

The VSC8486-04 device is available in three package types. VSC8486SN-04 is a 256-pin, flip chip ball grid array (FCBGA) with a 17 mm × 17 mm body size, 1 mm pin pitch, and 3.22 mm maximum height. The device is also available in lead-free (Pb-free) packages, VSC8486XSN-04 and VSC8486YSN-04. Note that for VSC8486XSN-04, only the second-level interconnect is lead-free.

Lead-free products from Microsemi comply with the temperatures and profiles defined in the joint IPC and JEDEC standard IPC/JEDEC J-STD-020. For more information, see the IPC and JEDEC standard.

The following table lists the ordering information for the VSC8486-04 device.

**Table 326 • Ordering Information**

Part Order Number	Description
VSC8486SN-04	256-pin FCBGA with a 17 mm × 17 mm body size, 1 mm pin pitch, and 3.22 mm maximum height
VSC8486XSN-04	Lead-free (second-level interconnect only), 256-pin FCBGA with a 17 mm × 17 mm body size, 1 mm pin pitch, and 3.22 mm maximum height
VSC8486YSN-04	Lead-free, 256-pin FCBGA with a 17 mm × 17 mm body size, 1 mm pin pitch, and 3.22 mm maximum height